



INTAKE SYSTEMS

Installation Instructions
Part Number 200-229
2004-05 Chevy HD Truck
Duramax Diesel
(Does not fit 2005 GMC)
Duramax Diesel 6.6L "LLY"

Packing List:

#1	720-472	Airaid Premium Filter	1
#2	KIT154-1T	Airaid Intake Tube	1
#3	KIT229CABS	Cold Air Box	1
#4	KIT1121MAFADA	Filter Adapter	1
#5	KITHUMPHS05	Urethane Hump Hose	1
#6	KITCOUPLER01	Urethane Coupler	1
#7	KITWSTRIP03	Weather Strip 25 1/2"	1
	KIT229HP	Hardware & Instructions	1
#8	KIT15DHC3050	1/4-20 x 1/2" Button Head	3
#9	KIT09FWZ019	1/4" Flat Washer	4
#10	KIT15BHC3050	8-32 x 1/2" Button Head	2
#11	KITHS60	#60 Hose Clamp	2
#12	KITHS72	#72 Hose Clamp	2
#13	KIT247B	Fender Bracket	1
#14	KIT25C75HCSS	1/4-20 x 3/4" Hex Bolt	1
#15	KIT1420WZZF	1/4-20 Flange Nut	1
#16	KITBIT01	T-20 Torx Bit	1

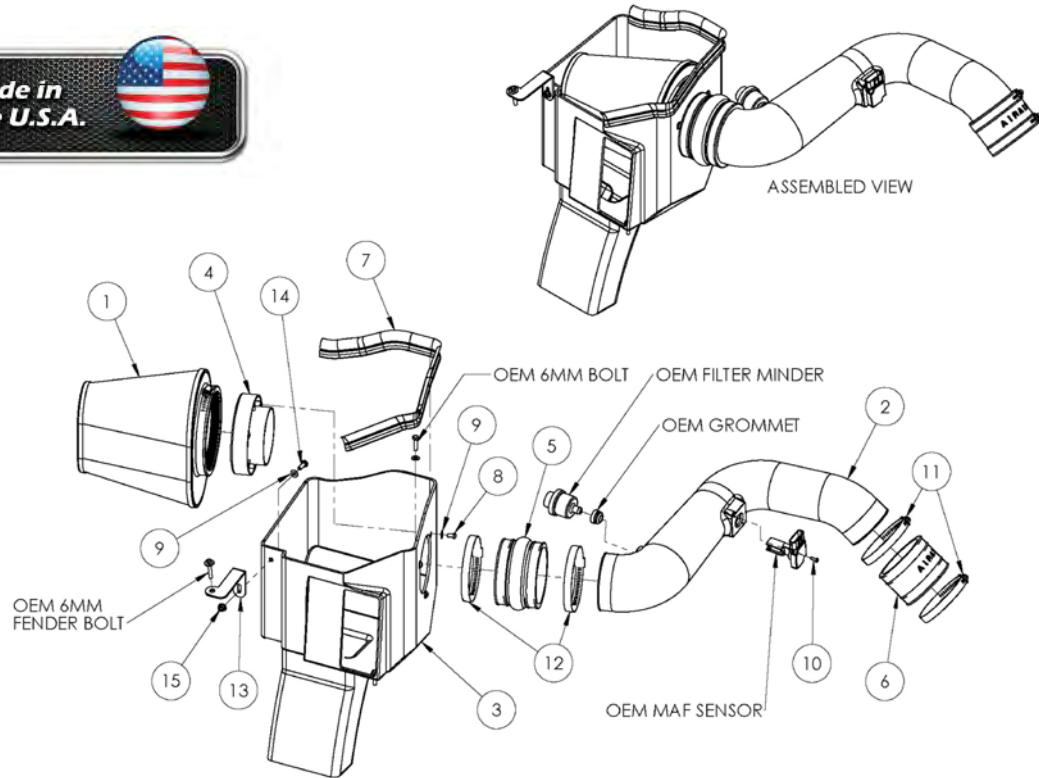

Tools Required For Installation:

Flat Head Screwdriver
 5/16", 1/4", 10mm and 13mm Socket
 Ratchet and Extension
 3/32" Allen Wrench
 #T20 Security Bit (Included)



1. Disconnect the negative battery cable.

Loosen the hose clamps on each end of the factory intake tube assembly and remove tube.



2. Disconnect the Mass Air Flow (M.A.F.) sensor and remove the factory airbox. Rock the factory air box back and forth and remove it from its mounting. It is held in place with grommets in,



3. Using a 10mm socket, remove the five bolts and mounting plate from the engine compartment. Do not discard factory bolts. Three of them will be re used in step 5.

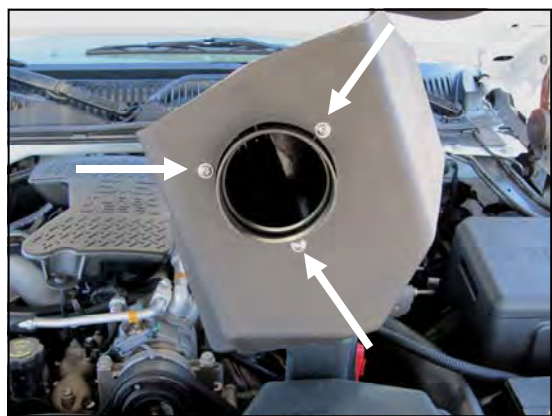

4. Install the Filter Adapter (#4) onto the Cold Air Box, or CAB (#3), as shown using the three 1/4-20 Button Head Bolts (#8) and 1/4" Washers (#9).



5. Install the Airaid Cold Air Box into the vehicle replacing the factory airbox. Secure the CAB using three of the bolts from step 3. Do not over tighten



6. Using a 13mm socket, remove the factory fender bolt and set it aside. It will be reused in step 7.



7. Install the Fender bracket (#13) as shown. A.) Secure the bracket to the fender using the factory bolt. B.) Use the 1/4-20 x 3/4" hex bolt (#14), one 1/4" flat washer (#9), and the 1/4-20 flange nut (#15) to secure the CAB to the Bracket.



8. Transfer the M.A.F. Sensor from the factory airbox into the Airaid intake tube (#2). Use the two 8-32 button head screws (#10). to secure the meter.

Do Not Use Factory Screws.



9. Transfer the factory rubber grommet and air filter minder from the airbox top into the Airaid intake tube As shown.



11. Install the urethane hump hose (#5) and two #72 hose clamps (#12) onto the large end of the Airaid intake tube. (*Note: Leave hose clamps loose until final assembly.*)



12. Install the urethane coupler (#6) and two #60 hose clamps (#11) onto the small end of the Airaid intake tube. (*Note: Leave hose clamps loose until final assembly.*)



13. Your complete Intake tube assembly should look like this.



14. A.) Install the hump hose end of the Airaid intake tube assembly onto the filter adapter first. B.) Slip the coupler end of the tube over the factory turbocharger inlet. Adjust for fit, and tighten the hose clamps



15. Install the Airaid Premium Filter (#1) onto the filter adapter, and tighten the hose clamp. Install the weather strip (#7) onto the Airaid Cold Air Box. Reconnect the M.A.F. sensor. (*Note: Start from one corner and work your way around to insure proper alignment of the weather strip.*)

16. Double check your work! Make sure there is no foreign material in the intake path. Make sure all clamps, hoses, bolts, and screws are tight.

16. Reconnect the negative battery cable!

Before!



After!



Thank you for purchasing the Airaid Intake System. Contact Airaid @ (800) 498-6951 8:00 AM - 5:00 PM MST weekdays for questions regarding fit or instructions that are not clear to you. Your Airaid Intake System was carefully inspected and packaged. Check that no parts are missing, or were damaged during shipping. If any parts are missing, contact Airaid. The air filter element is protected from direct exposure to water and debris; care should be taken not to drive through deep water. WATER INGESTION IS THE DRIVERS RESPONSIBILITY! The air filter is reusable and should be cleaned using the Airaid Filter Tune-Up Kit periodically.

Don't Forget Your AIRAID Filter Tune-Up Kit!



P/N 790-551 Aerosol Spray
P/N 790-550 Squeeze

Instructions Revision
Date: 07/15/13