

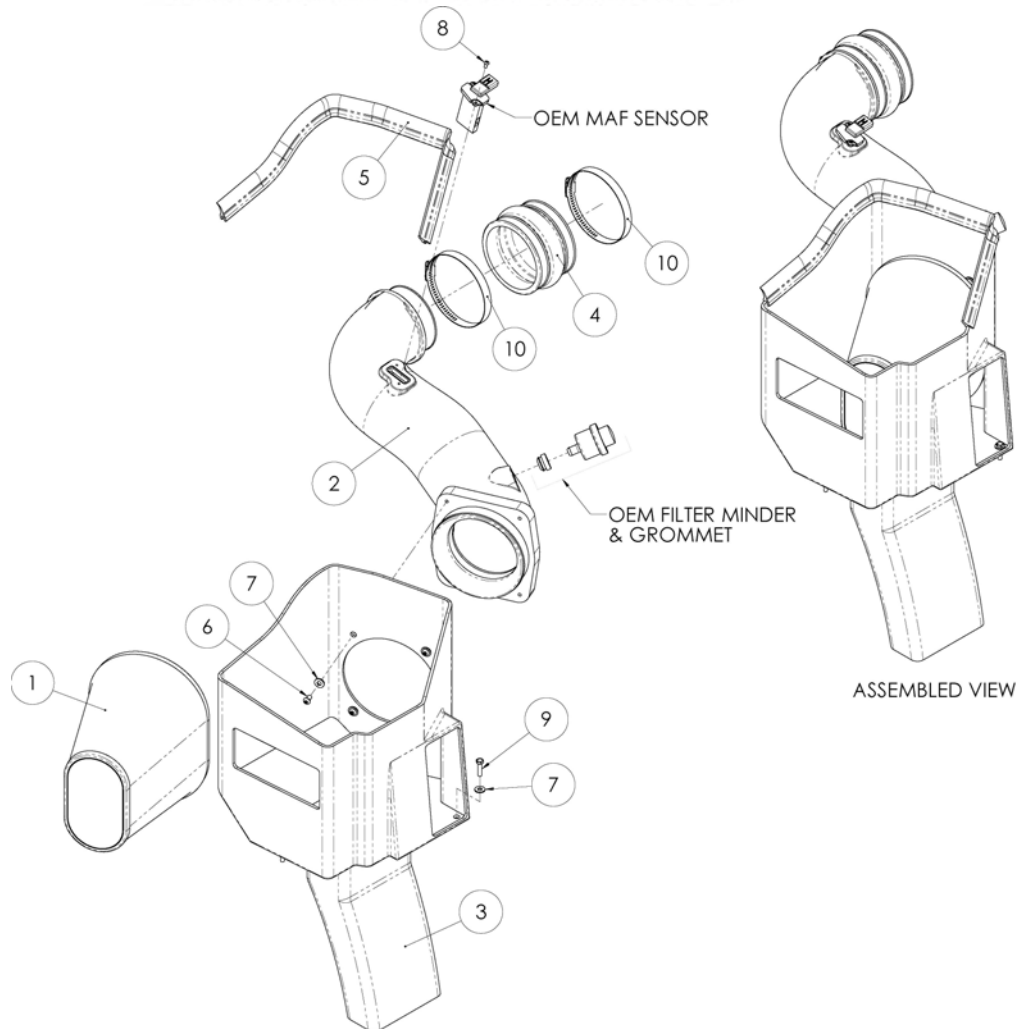

## INTAKE SYSTEMS



## Installation Instructions Part Number 201-219 2007-2010 Chevrolet/GMC GMT-900 Platform 6.6L Duramax LMM

### Packing List:

#1	721-472	Airaid Premium Filter	1
#2	KIT219T	Airaid Intake Tube	1
#3	KIT219CABS	Cool Air Box	1
#4	KITHUMPHS05	Urethane Hump Hose	1
#5	KITWSTRIP03	Weather Strip 25"	1
	KIT219HPS	Hardware & Instructions	1
#6	KIT15DHC3050	1/4 - 20 x 1/2" Button Head Bolt	4
#7	KIT09FWZ019	1/4" Flat Washer	7
#8	KIT15BHC3038	8-32 x 3/8" Button Head Screw	2
#9	KIT60C250HCS	M6 - 1 x 25mm Hex Bolt	3
#10	KITHS72	#72 Hose Clamp	2

### Tools Required For Installation:

5/32", 3/32" Allen Wrench  
5/16", 10mm Sockets  
Ratchet and Extension  
#20 Torx Bit



#### 1. Disconnect the negative battery cables.

A.) Using a #20 Torx bit remove the two screws and the Mass Air Flow sensor from the factory intake tube.

B.) Loosen the hose clamp at the rubber coupler.

C.) Remove the factory filter minder and grommet and save them for reinstallation in step # 7.



2. Rock the air filter housing back and forth while lifting up, and remove the factory intake assembly from the vehicle. There are only grommets holding it in place.



3. Using a 10mm socket, remove 4 bolts, and remove the factory air filter mounting plate.



4. Install the Airaid Cool Air Box (CAB) (#3) into the vehicle as shown, replacing the factory air filter. Install three M6-1 x 25mm bolts (#9), and three flat washers (# 7) thru the bottom of the CAB and into the factory captured nuts. Leave the bolts loose for now.



5. Install two #72 hose clamps (#10) onto the urethane hump hose (#4), and then slip the hump hose onto the end of the factory turbo intake tube as shown. Leave the clamps loose for now.

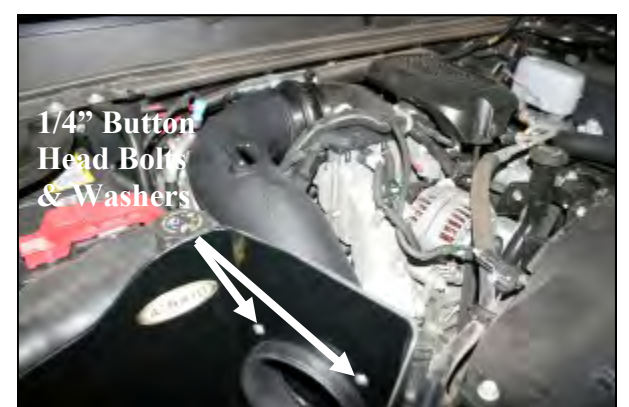

6. Slide the Airaid Intake Tube (#2) into the CAB first, and then into the hump hose. *If needed, the factory turbo intake tube can be adjusted for proper alignment.* Next install four 1/4" button head bolts (#6), and four flat washers (#7) thru the CAB to secure the Airaid Intake Tube. Now tighten the three bolts at the bottom of the CAB and the two hose clamps on the hump hose.



7. **A.)** Reinstall the Mass Air Flow sensor into the Airaid Intake Tube using two 8-32x 3/8" button head screws (#8). **Do Not Use The Factory Screws!** *It may be necessary to reroute the MAF sensor wiring harness so that it will reach the proper location in the tube.*  
**B.)** Next, reinstall the factory filter minder and grommet into the Airaid Intake Tube.



8. The Airaid Premium filter (#1) is a very tight fit in the CAB. For ease of installation, hold the filter in your right hand, and guide the bottom of the filter past the flange of the tube with your left hand inside of the CAB. **It will fit!** Tighten the hose clamp. Next install the weather strip (#5) on top of the CAB, starting at the fender and working your way towards the radiator.



9. Congratulations on the successful install of your new Airaid Intake System!  
**Double check your work!**  
 Make sure there is no foreign material in the intake path. Make sure all clamps, hoses, bolts, and screws are tight.  
**Reconnect the negative battery cables!**

*Before!*



*After!*



Thank you for purchasing the Airaid Intake System. Contact Airaid @ (800) 498-6951 8:00 AM - 5:00 PM MST weekdays for questions regarding fit or instructions that are not clear to you. Your Airaid Intake System was carefully inspected and packaged. Check that no parts are missing, or were damaged during shipping. If any parts are missing, contact Airaid. The air filter element is protected from direct exposure to water and debris; care should be taken not to drive through deep water. WATER INGESTION IS THE DRIVERS RESPONSIBILITY!

*SynthaMax*

**Do Not Oil**

Synthamax Air Filters do not require oil. Service air filter as needed by cleaning with common non-petroleum all-purpose household cleaner and water. Simple Green®, Formula 409® or equivalent works great. Apply cleaner to outside of air filter and allow to soak. Then flush filter clean from the inside out with a garden hose and repeat steps if necessary. Do not apply high pressure water or air to clean filter. Allow filter to air dry and re-install.



Instructions Revision  
 Date: 07/15/13