



INTAKE SYSTEMS

Installation Instructions Part Number 201-247 1999-06 GM Full Size SUVs and Trucks 2007 GMC Sierra "Classic" Truck 4.8L, 5.3L, 6.0L With Mechanical Cooling Fan and Low Profile Hood

Packing List:

#1	721-472	Airaid Premium Filter	1
#2	KIT912T	Airaid Intake Tube	1
#3	KIT247CABC	Cool Air Box	1
#4	KIT1121MAFADA	Air Filter Adapter	1
#5	KITHUMPHS02	Urethane Hump Hose	1
#6	KITCOUPLER02	Coupler W/ #68 Clamp	1
#7	KITWSTRIP03	Weather Strip 25"	1
	KIT247HPS	Hardware & Instructions	1
#8	KIT15DHC3050	1/4-20 x 1/2" Button Head Bolt	3
#9	KIT25C75HCSS	1/4-20x 3/4" Hex Bolt	1
#10	KIT25CNNS	1/4" Nylock Nut	1
#11	KIT09FWZ019	1/4" Flat Washer	8
#12	KIT60C250HCS	M6-1x25 Hex Bolt	3
#13	KITHS60	#60 Hose Clamp	2
#14	KIT247B	Bracket	1

Tools Required For Installation:

Flat Blade Screwdriver, 5/32" Allen Wrench
5/16", 7/16", 10mm, 13mm Sockets
Ratchet & Extension
7/16" Wrench

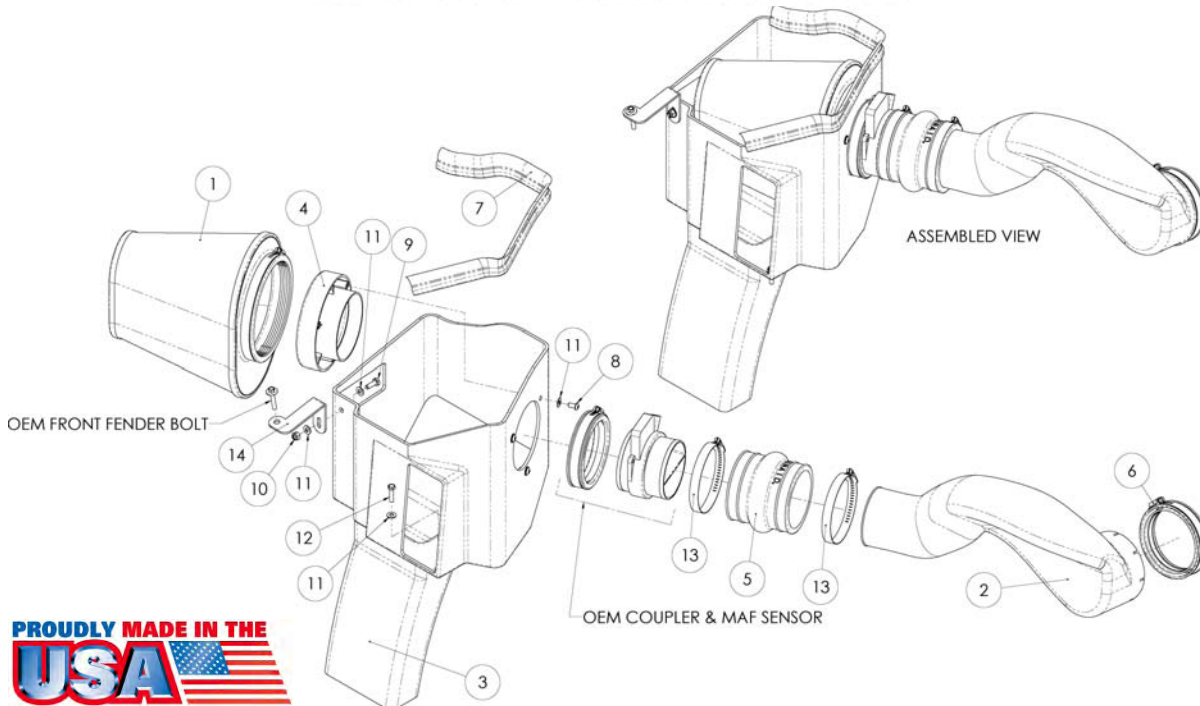

PROUDLY MADE IN THE
USA

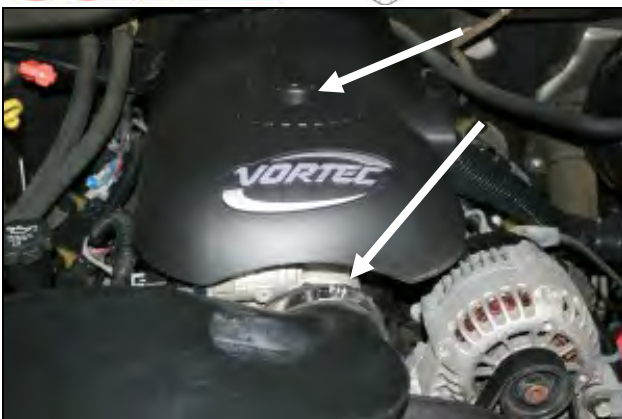

1. **Disconnect the negative battery cable.**
Loosen the bolt that secures the beauty cover to the engine and remove it and the cover from the vehicle. Loosen the hose clamp that secures the factory air intake tube to the throttlebody.

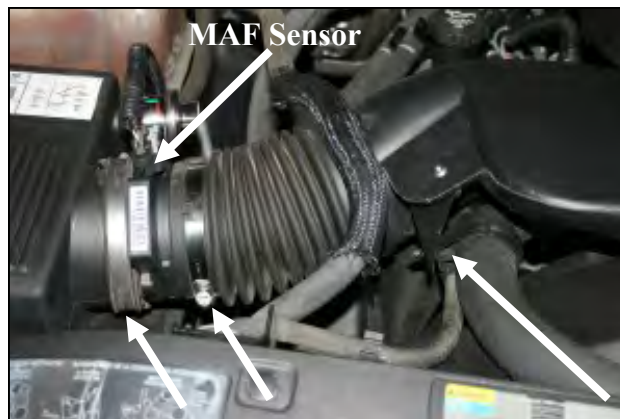

2. Loosen two hose clamps. One on each side of the Mass Air Flow (MAF) sensor. Using a flat blade screwdriver, disconnect the factory intake tube from the plastic clamp on the radiator hose by prying them apart.



3. Remove the factory intake tube from the vehicle. Next, remove the MAF sensor and coupler from the factory airbox and set them out of the way without disconnecting the wiring harness.



4. Rock the factory air box back and forth and then lift straight up remove it from the vehicle. There are only grommets holding it in, no bolts.

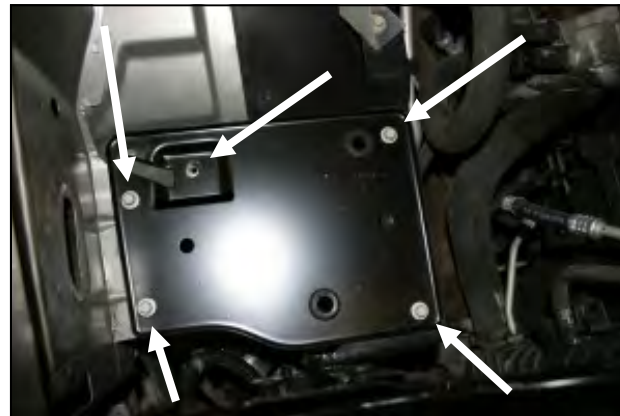

5. Using a 10mm socket, remove the bolts that secure the factory air filter housing platform and remove it from the vehicle.



6. Install the filter adapter (#4) into the Cool Air Box (#3) as shown using three 1/4" Button head bolts (#8) and three 1/4" flat washers (#11). Next, fasten the bracket to the front of the CAB as shown using one 1/4-20 hex bolt (#9) two flat washers (#10), and one 1/4" Nylock nut. Refer to the drawing above for reference.



7. Remove the factory bolt that secures the right front fender to the radiator support. It will be reused in step #8.



8. Install the CAB assembly into the vehicle where the factory airbox used to be using three 6mm hex bolts (#12) and three flat washers (#11) thru the bottom. Now reinstall the factory fender bolt thru the bracket and into the fender. Adjust the assembly for fit and tighten all bolts and nuts at this time.



9. Reinstall the MAF sensor and coupler onto the filter adapter and tighten the clamp. Next install the hump hose (#5) onto the MAF using two #60 hose clamps (#13). Leave these two clamps loose for now.



10. Install the provided coupler with clamp (#6) onto the large end of the Airaid Intake tube (#2). Do not tighten the clamp at this time.

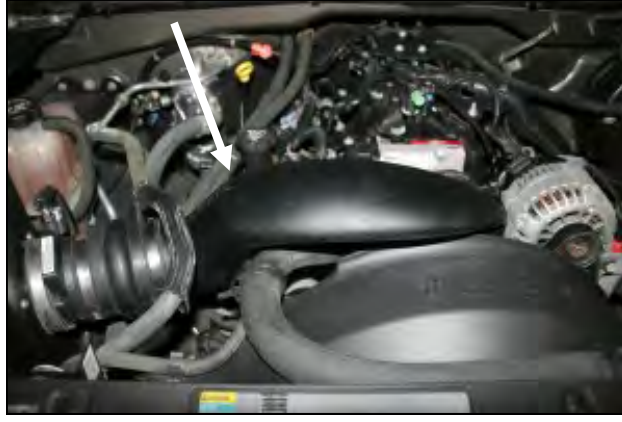

11. Install the small end of the intake tube into the hump hose first and then rotate it slightly to slide the other end onto the throttlebody. Adjust for fit, and then tighten all three hose clamps.



12. Install the provided weather strip (#7) along the top edge of the Airaid Cool Air Dam starting at the right fender working your way around towards the radiator. Install the Airaid Premium Filter (#1) onto the air filter adapter and tighten the hose clamp. Reinstall the factory beauty cover removed in step #1.

13. Double check your work!

Make sure there is no foreign material in the intake path. Make sure all clamps, hoses, bolts, and screws are tight. Double check the hood clearance. **Reconnect the negative battery cable!**

Note: Provisions have been made to mount the factory filter minder if you choose. A 17mm hole must be drilled on the back side of the tube. A circular impression on the rear of the tube indicates the correct location for the hole. Use the factory grommet to mount the filter minder.

Before!



After!



SynthaMax

Do Not Oil

Synthamax Air Filters do not require oil. Service air filter as needed by cleaning with common non-petroleum all-purpose household cleaner and water. Simple Green®, Formula 409® or equivalent works great. Apply cleaner to outside of air filter and allow to soak. Then flush filter clean from the inside out with a garden hose and repeat steps if necessary. Do not apply high pressure water or air to clean filter. Allow filter to air dry and reinstall.



Thank you for purchasing the Airaid Intake System. Contact Airaid @ (800) 498-6951 8:00 AM - 5:00 PM MST weekdays for questions regarding fit or instructions that are not clear to you. Your Airaid Intake System was carefully inspected and packaged. Check that no parts are missing, or were damaged during shipping. If any parts are missing, contact Airaid. The air filter element is protected from direct exposure to water and debris; care should be taken not to drive through deep water. WATER INGESTION IS THE DRIVERS RESPONSIBILITY!