

AIRRAID®

INTAKE SYSTEMS

#300-147 INSTALLATION INSTRUCTIONS

03-04 Dodge Ram 5.9L Cummins Diesel

(Note : Use P/N 300-159 For vehicles w/optional "quiet hood pad")

Thank you for purchasing the Airaid Intake System. Please read the instruction manual carefully before proceeding with the installation. Contact Airaid @ (800) 498-6951 8:00 AM - 5:00 PM MST weekdays for questions regarding fit or instructions that are not clear to you. Your Airaid Intake System was carefully inspected and packaged. Check that no parts are missing, or were damaged during shipping. If any parts are missing, contact Airaid. The air filter element is protected from direct exposure to water and debris; care should be taken not to drive through deep water. WATER INGESTION IS THE DRIVERS RESPONSIBILITY! The air filter is reusable and should be cleaned using the Airaid Filter Tune-Up Kit periodically.

Thank you for selecting Airaid.

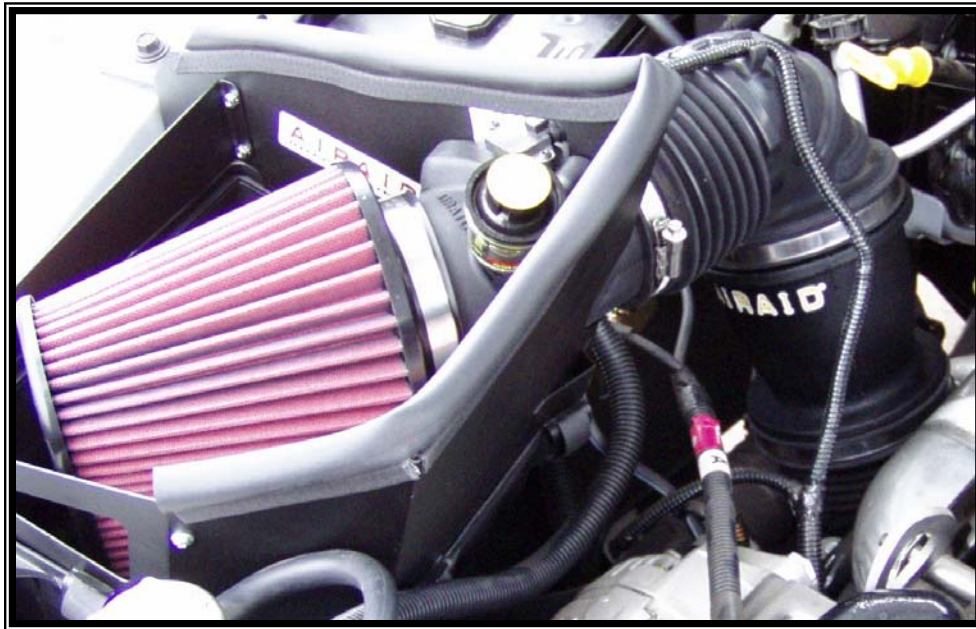

Packing List:

| | | |
|---------------|--------------------------|---|
| 720-128 | Airaid Premium Filter | 1 |
| KIT128FPC | Front Air Dam Panel | 1 |
| KIT128RPC | Rear Air Dam Panel | 1 |
| KIT928T | Modular Intake Tube | 1 |
| KIT128A | Adapter Tube | 1 |
| KITWSTRIP02 | Weather Strip 27" | 1 |
| KIT147HP | Hardware & Instructions | 1 |
| - KIT10BHCP63 | 8-32 Button Socket Screw | 2 |
| - KIT15FW3016 | #8 Flat Washer | 2 |

Packing List (cont'd):

| | | |
|----------------|------------------------|---|
| - KIT25C62HCSS | 1/4-20 x 5/8" Hex Bolt | 3 |
| - KIT09FWZ019 | 1/4" Flat Washer | 3 |
| - KIT6C31MXPPZ | 6-32 x 5/16" Screw | 4 |
| - KIT6CNKEPZ | 6-32 Nut | 4 |
| - KIT6NWSAPZ | #6 Flat Washer | 4 |

Tools Required for this Installation:

Flat Head Screwdriver
7mm & 8mm Sockets & Ratchet
3/32 Allen Wrench, T-20 bit

Installation Instructions. Read Me!

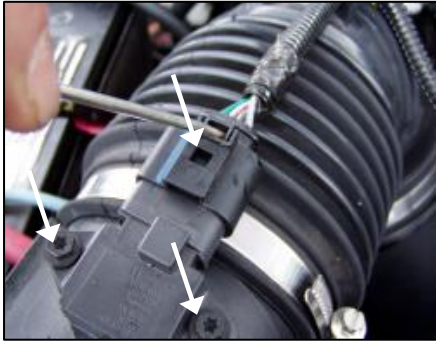

1. Disconnect the negative battery cable and disconnect the electrical connector. Using the T-20 bit, loosen the two star head bolts and remove the electrical sensor. (Retain sensor for installation of Airaid Intake System)



2. Remove the factory filter minder and rubber grommet. (Retain parts for installation of Airaid Intake System)



Filter Minder



Sensor



Factory Grommet

3. Parts to retain for installation of Airaid Intake System.



4. Loosen the hose clamp on the bottom of the factory intake tube that connects to the turbo housing.



5. Unclip the factory air box lid and remove entire filter/intake assembly from vehicle.



6. Remove factory tube assembly from vehicle. Disassemble assembly by loosening hose clamps on the factory intake assembly above and below the factory silencer tube.



7. Replace the factory silencer tube in the removed intake

assembly with the Airaid tube using the stock hose clamps.



8. Note: on each side of the tube are notches that must be aligned with the notches on the stock connector tubes. Also, the flow arrow must point down toward the turbo housing.



9. Check for any foreign objects or debris in the intake path & install complete tube assembly onto turbo charger using the stock hose clamp.

Continued on
next page...

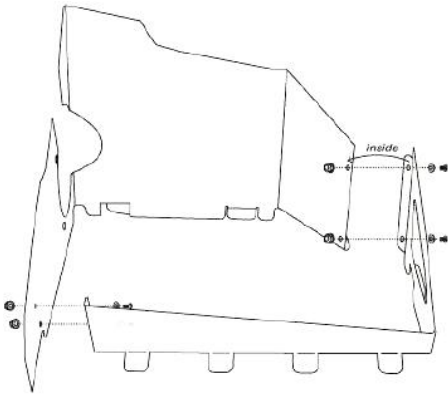

10. Assemble Airaid Quick Fit Cold Air Dam panels using the (4) 6/32 screws, washers and nuts provided.

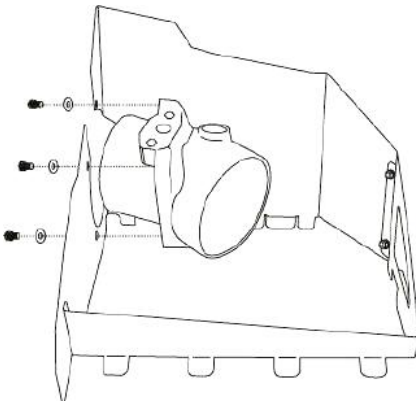

11. Assemble the air filter adapter to the cold air dam using the (3) 1/4-20 bolts and washers provided.

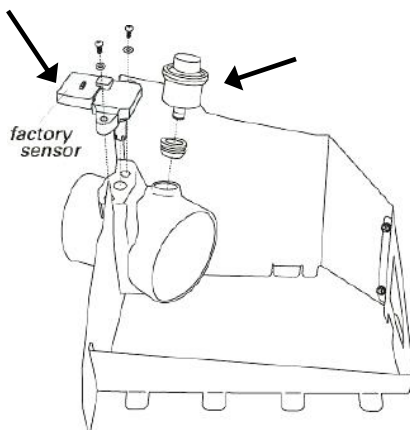

12. Fasten the factory sensor on top of the adapter using the (2) 8/32 screws and washers using a 3/32 Allen Wrench & mount the factory rubber grommet and filter minder onto the plastic adapter.

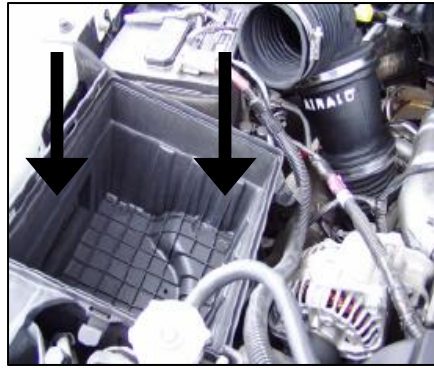

13. Install Airaid intake assembly in place of the factory air box lid & tighten factory hose clamp on intake tube to Airaid system.



14. Secure air intake tube to adapter using the factory hose clamp.

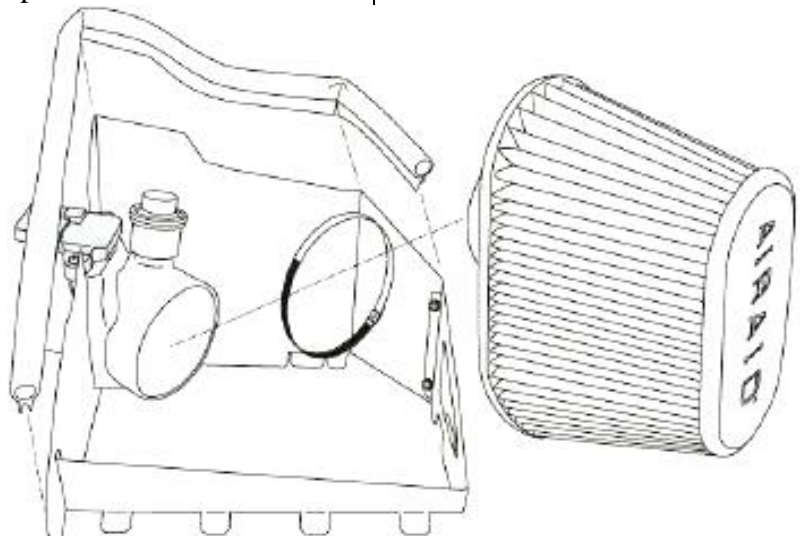

15. Mount Airaid Premium Filter to the filter adapter and tighten hose clamp, in addition; press the weather strip onto the top of the Airaid cool air dam.
(*Hint: start the install at the top corner of the cold air dam*)



16. Re-connect the wire harness to the sensor on top of the Airaid adapter.

17. Double check your work to be certain that all nuts, bolts, and clamps are securely fastened.

18. Reconnect the negative battery cable.



Before

After!

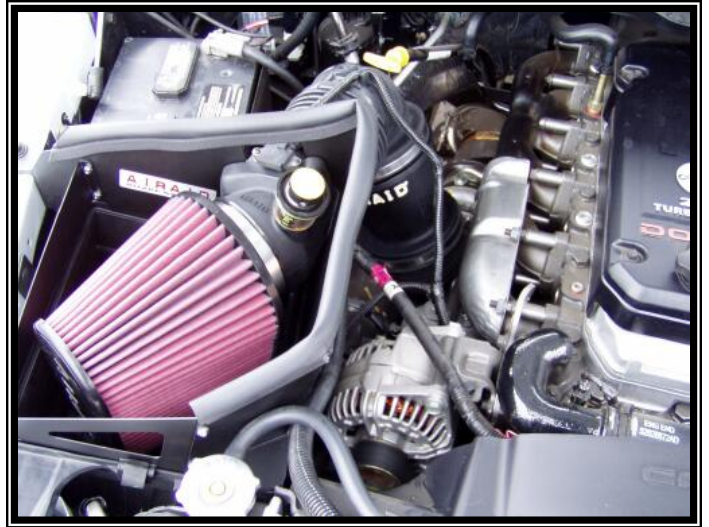

**Don't Forget
Your AIRAID
Filter Tune-Up
Kit!**



P/N 790-550

Instructions Revision
Date: 5/11/04