

AIRRAID®

INTAKE SYSTEMS



Installation Instructions
Part Number: 300-191 Intake Kit
2006 Dodge Ram
4.7L V-8

Packing List:

#1	700-445	Airaid Premium Filter	1
#2	KIT192DC	Cool Air Dam	1
#3	KIT925T	Modular Intake Tube	1
#4	KITHUMPHS01	Silicone Hump Hose	1
#5	KITWSTRIP02	Weather Strip 32 3/4"	1
	KIT191HP	Hardware & Instructions	1
#6	KITHS56	#56 Hose Clamp	3
#7	KITSNP14M4	#14 Speed Clamp	1
#8	KITSNP24GHS	#24 Speed Clamp	1
#9	KITGRMT02	Rubber Grommet	1
#10	KIT106CAP	Black Rubber Cap	1

Tools Required For Installation:

5/16" Socket & 10mm Socket
 Ratchet & Extension

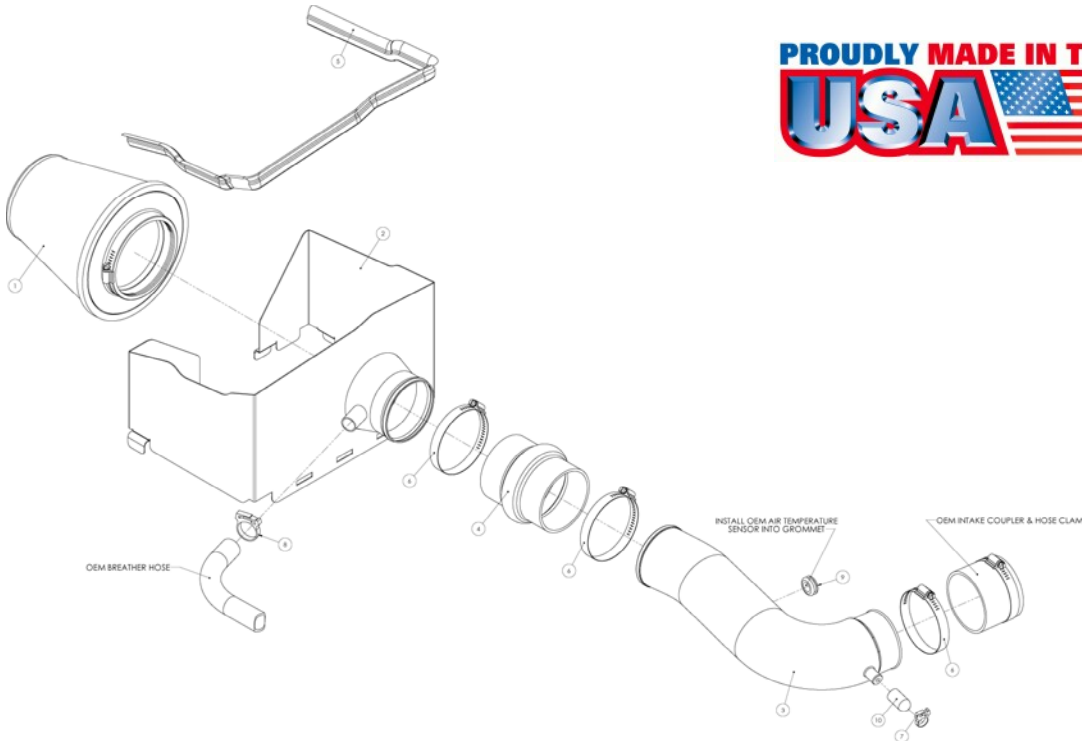

1. Disconnect the negative battery cable! Loosen the hose clamp on the resonator. Disconnect the breather hose going into the factory airbox lid.



2. Unlatch 4 clips on the factory airbox lid and remove the lid and intake hose assembly. Remove the factory air filter.

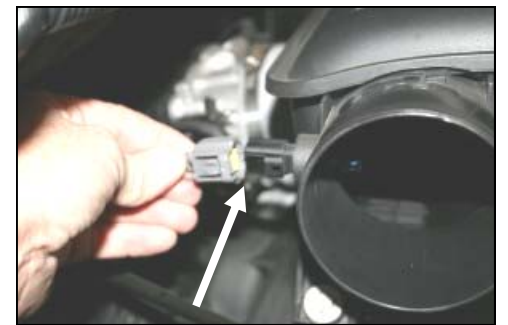

3. Squeeze the tab on the connector, and disconnect the air intake temperature sensor on the back of the resonator.

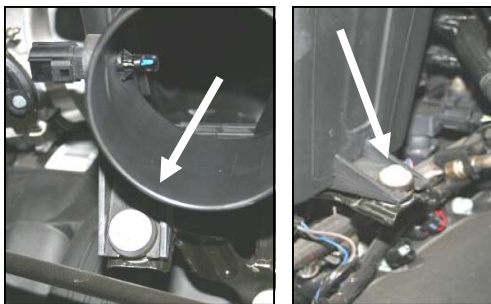

4. With a 10mm socket, remove two bolts holding the intake resonator to the intake manifold brackets.



5. Lift the front of the resonator straight up, and then pull towards you to remove it from the vehicle.



6. Gently twist the air temperature sensor counterclockwise and remove it from the resonator.



7. Install the supplied grommet (#9) into the Modular Intake Tube (#3). Next, carefully slide the factory temperature sensor into the grommet until it touches the tab on the temperature sensor.



8. Install the Cool Air Dam (#2) onto the factory airbox base by sliding the tabs on the base thru the CAD and then adjust the sides to fit. Relatch the 4 clips to hold the CAD securely in place.



9. Install the hump hose (#4) onto the tube on the CAD using two #56 hose clamps (#6). Leave clamps loose.



10. Install a #56 hose clamp (#6) on the factory throttle body coupler. Leave loose for now.



11. Install the Modular Intake Tube (#3) into the hump hose first and then into the factory coupler. Adjust for fit, and then tighten all 3 hose clamps.



12. Install the provided #24 speed clamp (#8) over the factory breather hose, then slide the hose onto the nipple on the CAD. Squeeze the clamp to secure the hose.

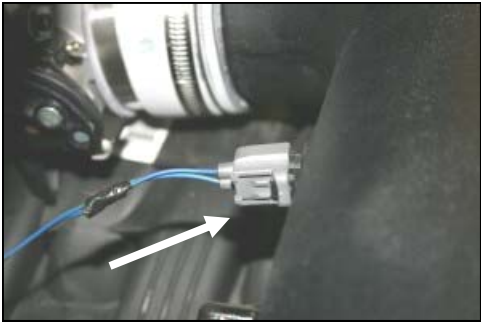

13. Re-connect the wiring harness to the factory temperature sensor on the back of the Modular Intake Tube (#3).

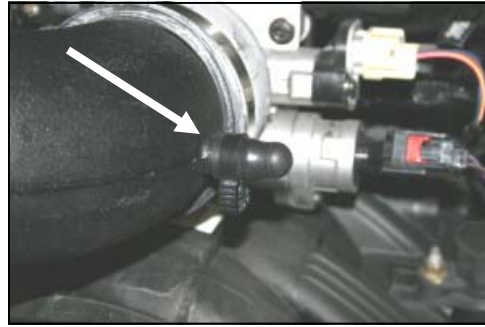

14. Install the provided rubber cap (#10), and speed clamp (#7) onto the nipple on the Modular Intake Tube (#3).



15. Install the Airaid Premium Filter (#1) onto the tube on the CAD and tighten the hose clamp. Next install the weather strip (#5) on the top of the CAD as shown. (Hint: Start at one corner and work towards the other corner. Don't start in the middle.)

16. Double check your work!

Make sure there is no foreign material in the intake path. Make sure all clamps, hoses, and wiring connections are tight.

17. Reconnect the negative battery cable!

Thank you for purchasing the Airaid Intake System. Contact Airaid @ (800) 498-6951 8:00 AM - 5:00 PM MST weekdays for questions regarding fit or instructions that are not clear to you. Your Airaid Intake System was carefully inspected and packaged. Check that no parts are missing, or were damaged during shipping. If any parts are missing, contact Airaid. The air filter element is protected from direct exposure to water and debris; care should be taken not to drive through deep water. WATER INGESTION IS THE DRIVERS RESPONSIBILITY! The air filter is reusable and should be cleaned using the Airaid Filter Tune-Up Kit periodically.

Before!



After!



Don't Forget Your AIRAID Filter Tune-Up Kit!



P/N 790-551 Aerosol Spray
P/N 790-550 Squeeze Spray



Instructions Revision
Date: 12/08/05