

AIR AID®

INTAKE SYSTEMS

Installation Instructions
Part Number 300-198
2006-10 Chrysler PT Cruiser
2.4L I-4 Non Turbo

Packing List:

#1	720-432	Airaid Premium Filter	1
#2	KIT198RPC	Rear Panel	1
#3	KIT198FPC	Front Panel	1
#4	KITELBOW05	Rubber Elbow	1
#5	KITRDCR06	Reducer Bushing	1
#6	KITWSTRIP02	Weather Strip 25 1/2"	1
	KIT198HP	Hardware & Instructions	1
#7	KITHS48	#48 Hose Clamp	2
#8	KIT6C31MXPPZ	6-32x 5/16" Screw	4
#9	KIT6NWSAPZ	#6 Flat Washer	4
#10	KIT6CNKEPZ	6-32 Keps Nut	4

Tools Required For Installation:

5/16" Socket
 Ratchet & Extension
 Phillips Screwdriver

**C.A.R.B. E.O. Number Applies Only To
 Listed Vehicles Up Thru 2008 Models
 All Others Pending**

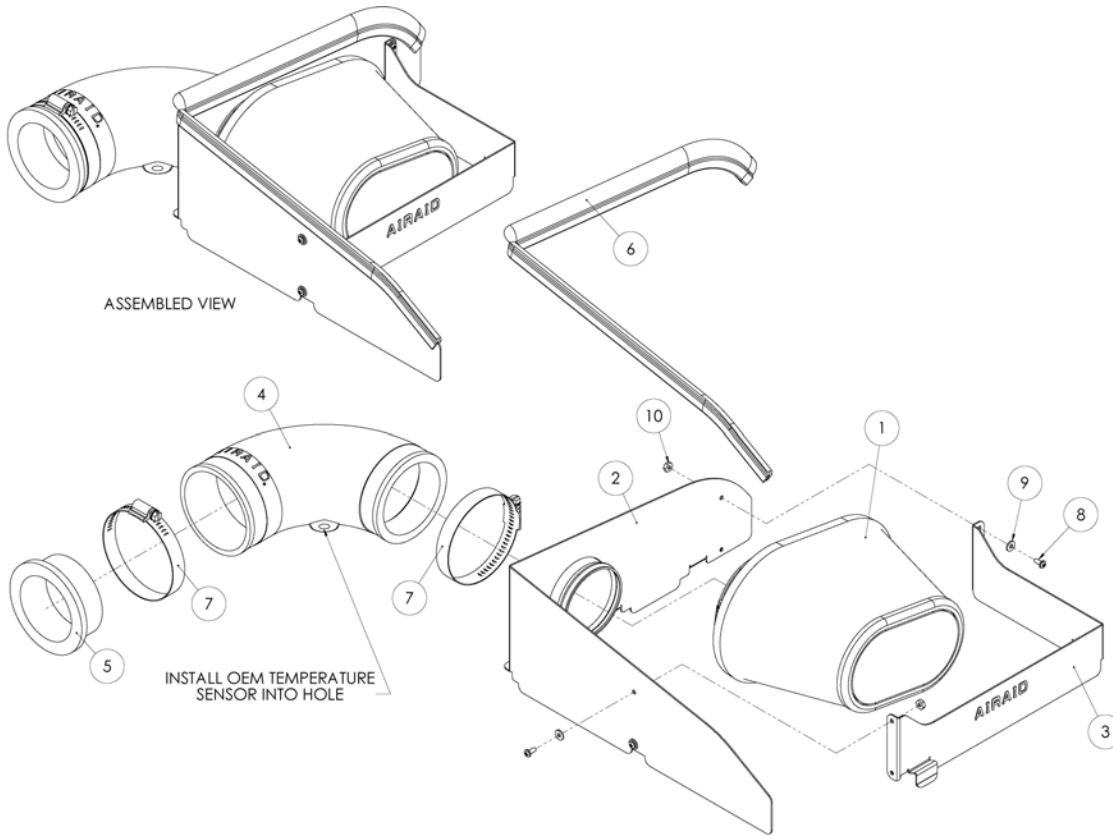

1. Disconnect the negative battery cable. Slide the red tab up on the temperature sensor, and then squeeze the black tab at the top of the sensor, and disconnect the wiring harness from the temperature sensor. Next loosen the two hose clamps at each end of the factory intake tube.



2. Unhook the two metal clips that hold the factory air cleaner lid to the base of the air cleaner box.



3. Remove the factory air cleaner lid by lifting up on the front, and then sliding the tabs out of the back of the air cleaner base.



4. Remove the factory air filter from the base of the air cleaner box.



5. Remove the factory air intake tube from the throttle body.



6. Carefully remove the temperature sensor from the factory intake tube and set it aside, it will be re-used in step #10.



7. Assemble the Quick Fit Panels (#2 & #3) as shown, using the four provided screws (#8), washers (#9), and nuts (#10).

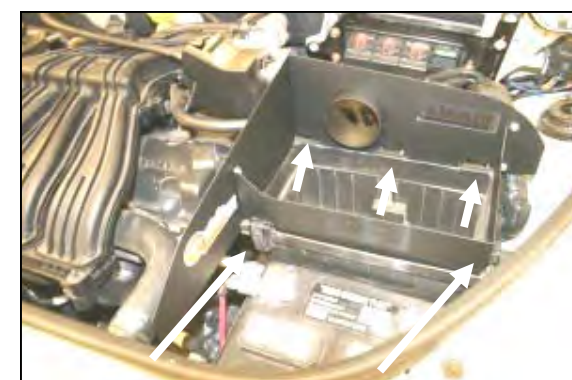

8. Install the three tabs of the assembled Quick Fit Panel into the three slots on the back of the factory air cleaner base, adjust the panels to fit in the slot around the top of the base, and re-latch the two factory clips to secure the panels to the base.



9. Install the reducer bushing (#5) into large end of the rubber elbow (#4).

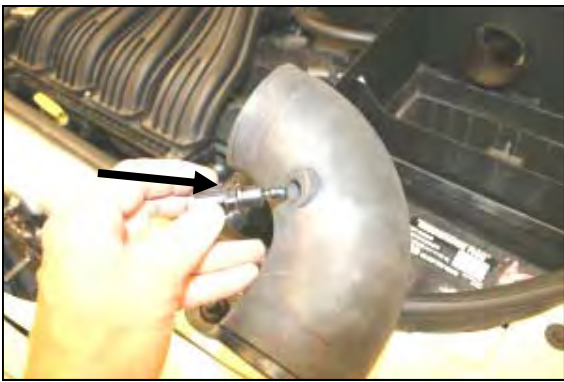

10. Very carefully, install the factory temperature sensor removed in step #6, into the Airaid intake tube. Make sure it is seated all the way in.

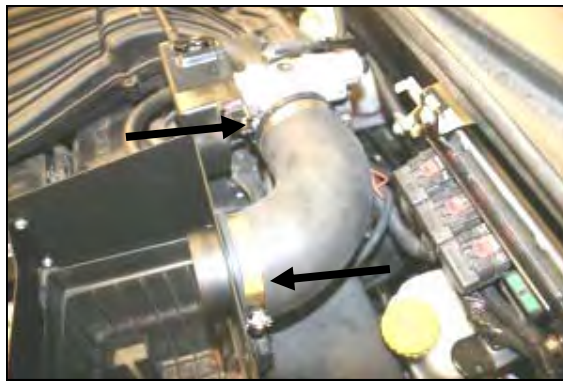

11. Install two #48 hose clamps (#7) on the Airaid intake tube, and then install the Airaid intake tube from the Quick Fit panel to the throttle body, making sure the reducer end is towards the throttle body. Tighten the hose clamps, and re-connect the temperature sensor wiring harness.

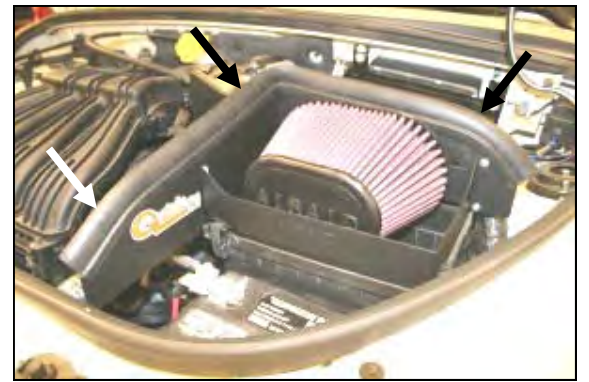

12. Install the Airaid Premium Filter (#1) onto the Quick Fit Panel, and tighten the hose clamp. Next install the weather strip (#6), as shown, onto the top of the Quick Fit Panel starting at the front and working your way towards the back.

13. Double check your work!

Make sure there is no foreign material in the intake path. Make sure all clamps, hoses, bolts, and screws are tight.

14. Re-connect the negative battery cable!

Included with your Airaid Intake System is a sticker with a California Air Resources Board (C.A.R.B.) Executive Order (EO) number. This sticker must be placed in plain view inside of the engine compartment. Failure to do so may prevent you from passing a smog inspection.

Before!



After!



Thank you for purchasing the Airaid Intake System. Contact Airaid @ (800) 498-6951 8:00 AM - 5:00 PM MST weekdays for questions regarding fit or instructions that are not clear to you. Your Airaid Intake System was carefully inspected and packaged. Check that no parts are missing, or were damaged during shipping. If any parts are missing, contact Airaid. The air filter element is protected from direct exposure to water and debris; care should be taken not to drive through deep water. WATER INGESTION IS THE DRIVERS RESPONSIBILITY! The air filter is reusable and should be cleaned using the Airaid Filter Tune-Up Kit periodically.

Don't Forget Your AIRAID Filter Tune-Up Kit!



P/N 790-551 Aerosol Spray
P/N 790-550 Squeeze Spray

Instructions Revision
Date: 01/21/10