

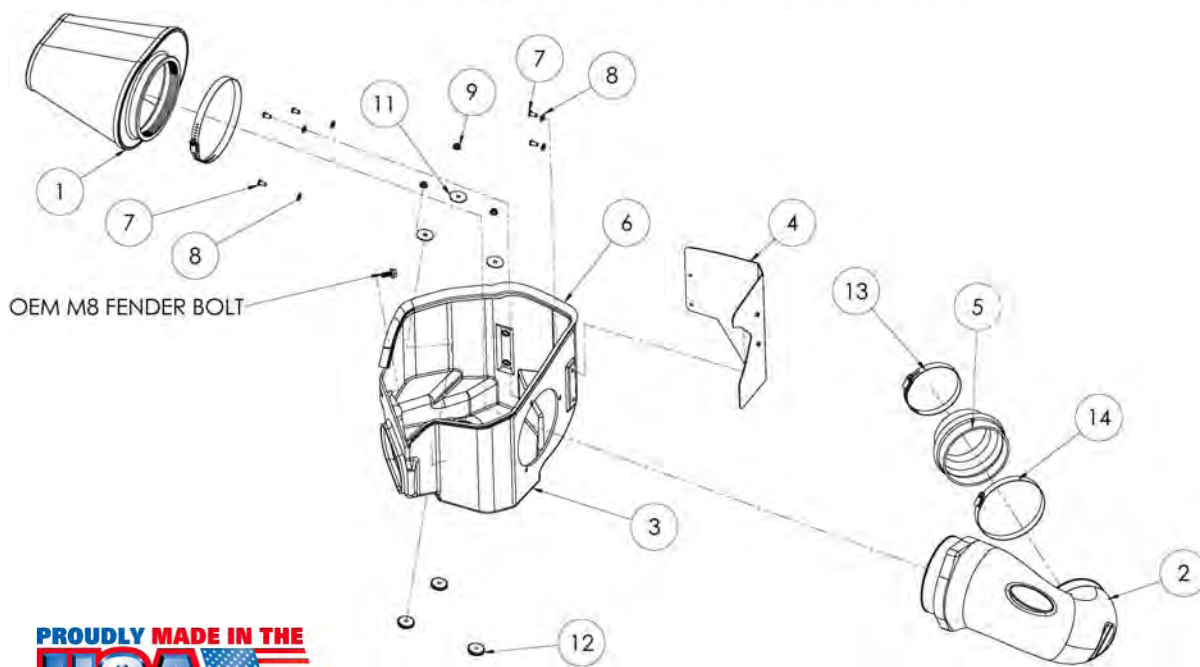

INTAKE SYSTEMS



PROUDLY MADE IN THE
USA

Installation Instructions Part Number 300-269 MXP 1994-02 Dodge Ram 5.9L Cummins Diesel

Packing List:

#1	720-472	Airaid Premium Filter	1
#2	KIT269T	Airaid Intake Tube	1
#3	KIT269CAB	Cool Air Box	1
#4	KIT269HS	Heat Shield	1
#5	KITRDCR17	Silicone Reducer	1
#6	KITWSTRIP03	Weather Strip 36 1/2"	1
#6	KIT269HP	Hardware & Instructions	1
#7	KIT15DHC3050	1/4 x 20 Button Head Screw	7
#8	KIT09FWZ019	1/4" Flat Washer	7
#9	KIT60CNFHPZ	6mm Flange Nut	3
#10	KIT1420WZZF	1/4" x 20 Flange Nut (Optional)	3
#11	KIT09FEZ025125	1/4" Fender Washer	3
#12	KITGRMT08	1/4" ID Grommet	3
#13	KITHS64	#64 Hose Clamp	1
#14	KITHS80	#80 Hose Clamp	1

Tools Required For Installation:

Ratchet & Extension
5/16", 10mm, 13mm Sockets
5/32" Allen Wrench

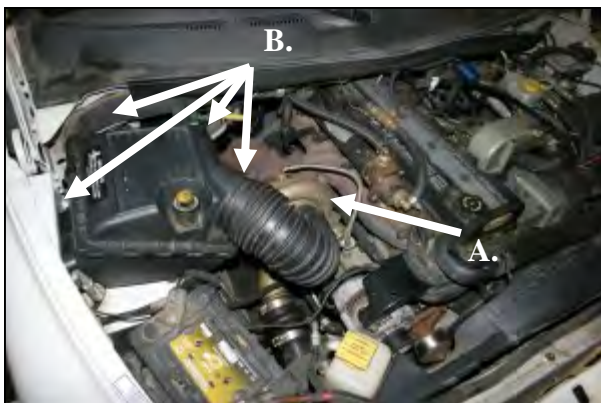

1. Disconnect the negative battery cables.
A) Loosen the hose clamp on the factory turbo inlet tube. B) Unfasten the Four clips on the right, left, and back side of the airbox. Remove the airbox lid and tube as an assembly and set aside.



2. Remove the factory air filter from the lower half of the factory airbox.



3. Locate the fender air scoop inside of the factory air box and remove it by pulling outward. The remaining factory airbox half can now be removed by simply pulling upward and off of the mounting studs on the inner fender well.



4. Attach the Intake Tube (#2) to the Cool Air Box, (CAB) (#3) using three 1/4" Button Head Bolts (#7) and Flat Washers (#8) as shown. Do not fully tighten the bolts at this time.

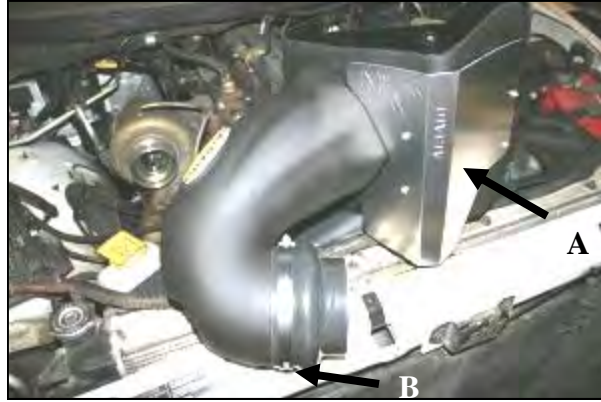

5. A) Install the aluminum Heat Shield (#4) onto the CAB using the four 1/4" Button head Bolts (#7) and the Flat washers (#8). Remove the protective film from Heat Shield. **B)** Install the silicone reducer (#5) on to the Airaid Intake Tube (#2) using the #80 (#14) Hose Clamp.

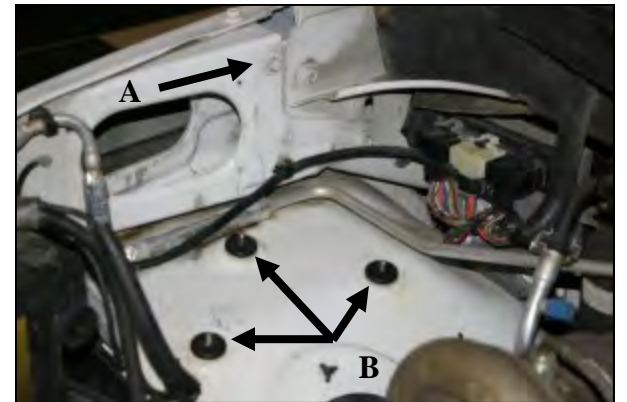

6. A) Remove the Factory 8mm fender bolt and set aside, it will be reused later in step 8. **B)** Place the 1/4" I.D. Grommets (#12) over each of the three studs on the inner fender.

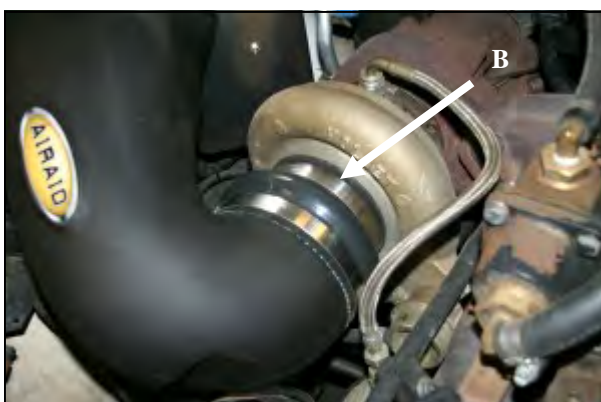

7. A) Install the CAB and Tube assembly onto the turbo inlet first, then rotate the assembly downward onto the inner fender studs. **B)** Secure the Silicone reducer to the turbo inlet using the #64 Clamp (#13). **C)** Fully tighten the three 1/4" Button Head Bolts from step 4.



8. A) Determine the stud size of your particular vehicle, and secure the CAB using the appropriate washers and nuts. Vehicles with SAE studs will use the 1/4" x 20 Flanged Nuts (#10) and three Fender washers (#11). Vehicles with Metric studs will use the 6mm Flanged Nuts (#9) and three Flat Washers (#11). **B)** Reinstall the Factory 8mm bolt through the CAB and into its original location.



9. Install the Airaid Premium Filter (#1) onto the Intake tube as shown and tighten the clamp. Install the Weatherstrip (#6) onto the top edge of the CAB starting from the front and work your way back

13. Double check your work!

Make sure there is no foreign material in the intake path. Make sure all clamps, hoses, bolts, and screws are tight.

14. Reconnect the negative battery cables!

Thank you for purchasing the Airaid Intake System. Contact Airaid @ (800) 498-6951 8:00 AM - 5:00 PM MST weekdays for questions regarding fit or instructions that are not clear to you. Your Airaid Intake System was carefully inspected and packaged. Check that no parts are missing, or were damaged during shipping. If any parts are missing, contact Airaid. The air filter element is protected from direct exposure to water and debris; care should be taken not to drive through deep water. WATER INGESTION IS THE DRIVERS RESPONSIBILITY! The air filter is reusable and should be cleaned using the Airaid Filter Tune-Up Kit periodically.

Before!



After!



Turbo Upgrade Install Options:

Airaid's Part Number 300-269 can be installed on vehicles with aftermarket turbo inlets up to 5" with the use of pn KIT 140-500. Please contact Airaid, or your nearest Retailer, for other sizing options.



KIT 140-500
1 Qty 5" silicone Hump Hose
2 Qty # 80 Hose clamp

Don't Forget Your AIRAID Filter Tune-Up Kit!



P/N 790-551 Aerosol Spray
P/N 790-550 Squeeze Spray



Instructions Revision
Date:08/30/10