

AIR AID®

INTAKE SYSTEMS

Installation Instructions
Part Number 351-193
2006-10 Dodge Charger SRT-8/Super Bee
2008 Dodge Magnum SRT-8
6.1L With Hood Scoop

Tools Required For Installation:

5/32", 7/32" Allen Wrenches
 5/16", 7/16", & 10mm Sockets
 Ratchet & Extension
 Phillips Screwdriver

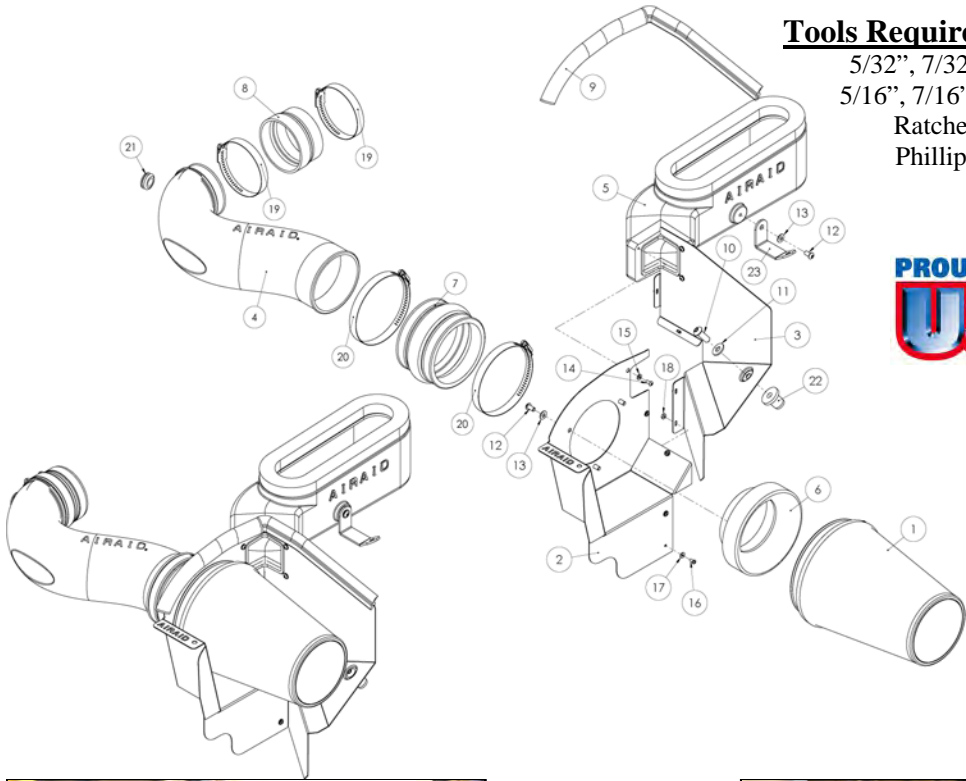

Packing List:

#1	701-469	Airaid Premium Filter	1
#2	KIT1931MAFC	MAF Panel	1
#3	KIT1931BPC	Back Panel	1
#4	KIT193T	Airaid Intake Tube	1
#5	KIT193HST	Hood Scoop Tube	1
#6	KIT1121MAFADA	Filter Adapter	1
#7	KITHUMPHS05	Urethane Hump Hose	1
#8	KITRDCR04	Reducing Coupler	1
#9	KIT172WS02	Weather Strip 20 1/2"	1
	KIT193HPS	Hardware & Instructions	1
#10	KIT15BHC3100	3/8-16 x 1" Button Head Bolt	1
#11	KIT31NWUSPZ	3/8" Flat Washer	1
#12	KIT15DHC3050	1/4 - 20 Button Head Bolt	4
#13	KIT09FWX019	1/4" Flat Washer	4
#14	KIT15BHC3038	8-32 x 3/8" Button Head Screw	3
#15	KIT15FW3016	#8 Flat Washer	3
#16	KIT6C31MXPPZ	6-32 x 5/16" Screw	4
#17	KIT6NWSAPZ	#6 Flat Washer	4
#18	KIT6CNKEPZ	6-32 Keps Nut	4
#19	KITHS52	#52 Hose Clamp	2
#20	KITHS72	#72 Hose Clamp	2
#21	KITGRMT02	Grommet	1
#22	KITNUT01	Well Nut	1
#23	KIT193B	L-Bracket	1



1. Disconnect the negative battery cable.
 Loosen the hose clamp that holds the factory intake tube to the throttle body.



2. Disconnect the breather hose from the factory airbox lid.



3. Pull both lockdown tabs towards you on the factory airbox lid to remove the lid from the base.



4. Lift the intake tube towards you, and without disconnecting the wiring harness, gently remove the temperature sensor from the factory intake tube, and set it aside.



5. Remove the factory intake hose and lid assembly from the vehicle. Remove the factory air filter.

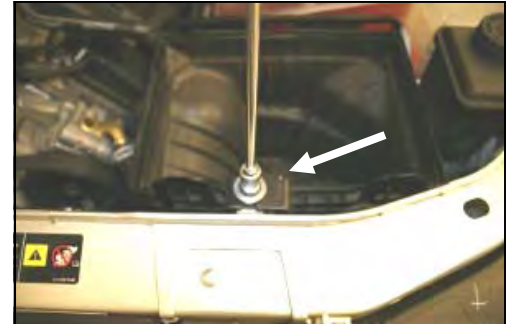

6. With a 10mm socket, remove and save the bolt that holds the factory air filter base to the radiator support. Remove the air filter base from the vehicle.



7. Assemble the Airaid Cool Air Dam (CAD) panels (#2, #3) using four 6-32 x 5/16" screws (#16), #6 flat washers (#17), and 6-32 keps nuts (#18).

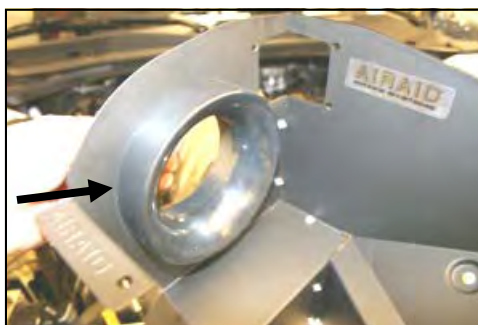

8. Next install the filter adapter (#6) using three 1/4 - 20 button head bolts (#12), and 1/4" flat washers (#13).



9. Slip the well nut (#22) into the hole in the inner fender.

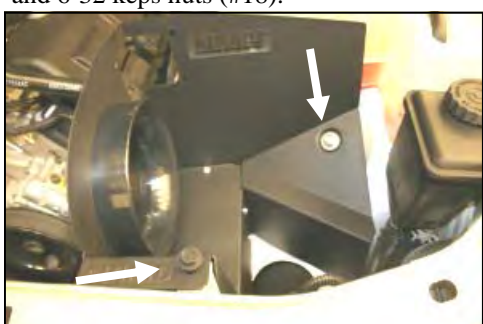

10. Install the assembled Cool Air Dam into the vehicle. Re-install the factory bolt removed in step #6 thru the CAD and into the radiator support. Next install the 3/8-16 x 1" button head bolt (#10) and 3/8" flat washer (#11) thru the CAD and into the well nut. Tighten both bolts.

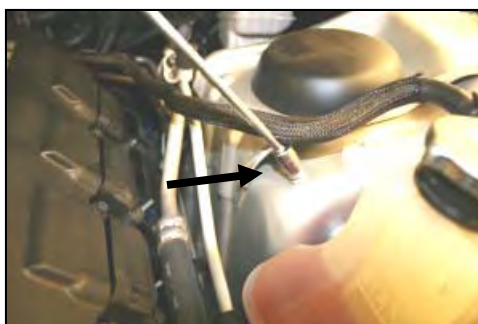

11. Remove the factory 10mm nut from the stud on the driver's side inner fender and save it for the next step.



12. Install the hood scoop into the CAD using three 8-32 x 3/8" button head screws (#14), and three #8 flat washers (#15), leave loose. Install the L-bracket (#23) over the stud on the fender, and bolt it to the hood scoop using one 1/4-20 button head bolt (#12), and 1/4" flat washer (#13). Replace the factory nut on the stud, adjust for fit, and tighten all bolts, nuts, and

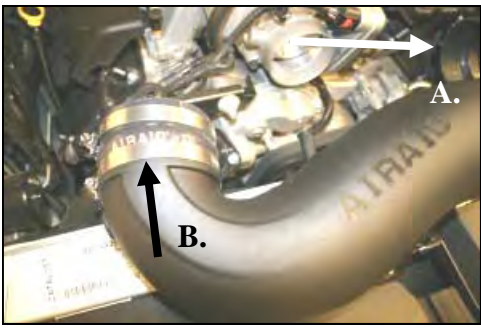

13. **A.** Install the urethane hump hose (#7) on the filter adapter using two #72 hose clamps (#20), (*Leave loose for now*). **B.** Install the reducing coupler (#8) large end on the Airaid Intake Tube (#4), using two #52 hose clamps (#19). Tighten *only* the hose clamp on the tube.

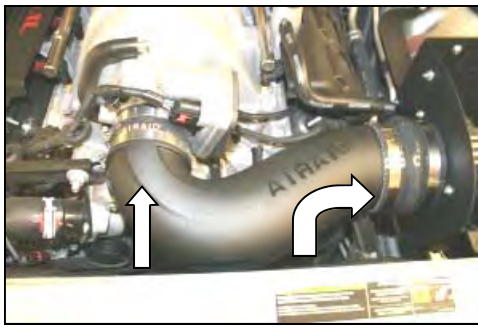

14. Install the Airaid Intake Tube into the hump hose first, and then onto the throttle body, making sure it is flush against the throttle body, adjust for fit, now tighten all of the hose clamps.

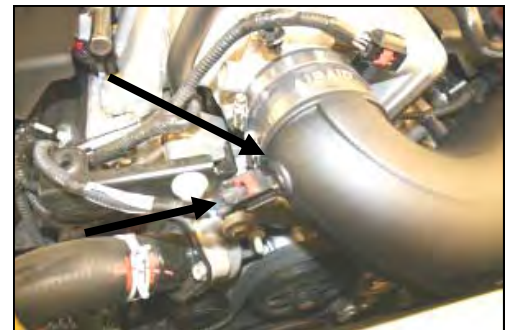

15. Install the grommet (#21) into the hole in the Airaid Intake Tube, and then gently push the temperature sensor (*removed in step #4*) thru the grommet until completely seated.

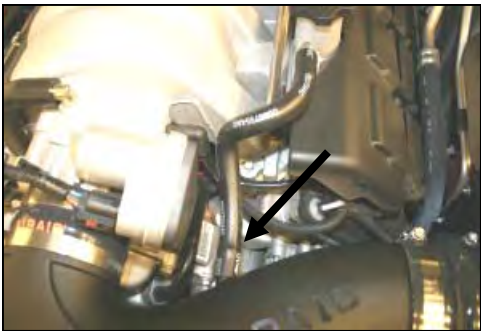

16. Re-connect the factory breather tube to the Airaid Intake Tube as shown.



17. Install the Airaid Premium Filter (#1), onto the filter adapter inside of the CAD, and tighten the hose clamp. Next install the weather strip (#9) onto the top of the CAD.

18. Double check your work! Make sure there is no foreign material in the intake path. Make sure all clamps, hoses, bolts, nuts, and screws are tight. Double check the hood clearance.

19. Reconnect the negative battery cable!

Thank you for purchasing the Airaid Intake System. Contact Airaid @ (800) 498-6951 8:00 AM - 5:00 PM MST weekdays for questions regarding fit or instructions that are not clear to you. Your Airaid Intake System was carefully inspected and packaged. Check that no parts are missing, or were damaged during shipping. If any parts are missing, contact Airaid. The air filter element is protected from direct exposure to water and debris; care should be taken not to drive through deep water. WATER INGESTION IS THE DRIVERS RESPONSIBILITY!

Before!



After!



SynthaMax

Do Not Oil

Synthamax Air Filters do not require oil. Service air filter as needed by cleaning with common non-petroleum all-purpose household cleaner and water. Simple Green®, Formula 409® or equivalent works great. Apply cleaner to outside of air filter and allow to soak. Then flush filter clean from the inside out with a garden hose and repeat steps if necessary. Do not apply high pressure water or air to clean filter. Allow filter to air dry and reinstall.



Instructions Revision
Date: 10/26/10