

# AIR AID®

## INTAKE SYSTEMS

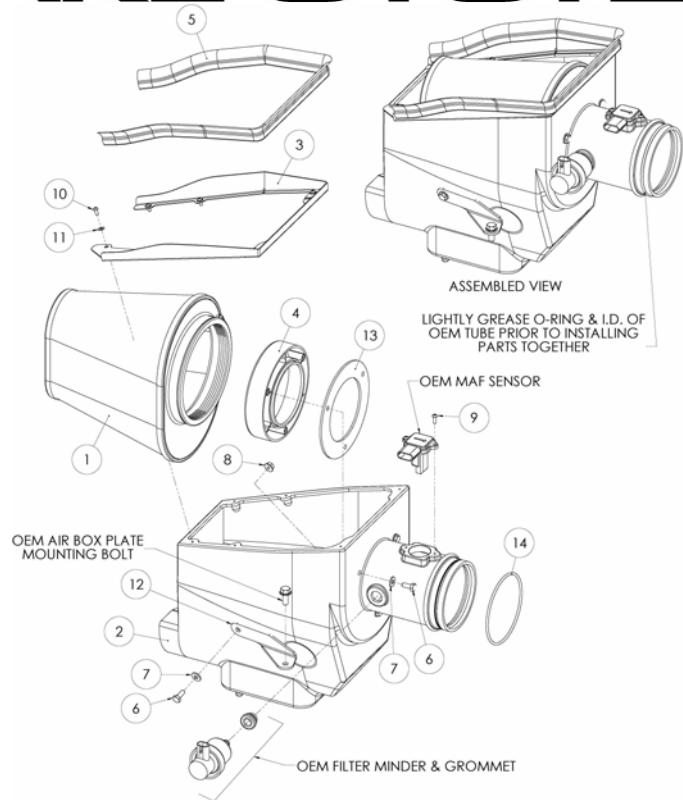

**Installation Instructions**  
**Part Number 400-214-1**  
**2008-10 Ford F-250 Thru F-550 SuperDuty**  
**Powerstroke 6.4L**

### Packing List:

#1	720-472	Airaid Premium Filter	1
#2	KIT214CAB	Airaid Cool Air Box	1
#3	KIT214TPC	Top Panel	1
#4	KIT214FADA	Filter Adapter	1
#5	KITWSTRIP02	Weather Strip 33 1/4"	1
	KIT214HP	Hardware & Instructions	1
#6	KIT25C62HCSS	1/4-20x5/8" Hex Bolt	4
#7	KIT09FWZ019	1/4" Flat Washer	4
#8	KIT1420WZZF	1/4-20 Serrated Nut	1
#9	KIT15BHC3050	8-32x1/2" Button Head Bolt	2
#10	KIT10BHCP38	8-32x3/8" Button Head Bolt	6
#11	KIT15FW3016	#8 Flat Washer	6
#12	KIT9401B	Bracket	1
#13	KIT214G	Adapter Gasket	1
#14	KIT214OR	1/8" x 4" O-Ring	1
	KITBIT#T20	T20 Torx Security Bit	1
	KIT76768	O-Ring Grease	1

Save these Parts for the Alternate Assembly Refer To The Drawing On Page 2 For The Following Parts			
#15	KIT15BHC3038	8-32x3/8" Button Head Screw	2
#16	KIT15FHC3016	8-32x1/2" Flat Head Screw	2
#17	KIT214PLT	Calibration Plate	1

### Tools Required For Installation:

1/4", 5/16", 7/16", 13mm Sockets  
 3/32" Allen Wrench  
 7/16" Wrench  
 Ratchet & Extension  
 T20 Torx Security Bit (Included)

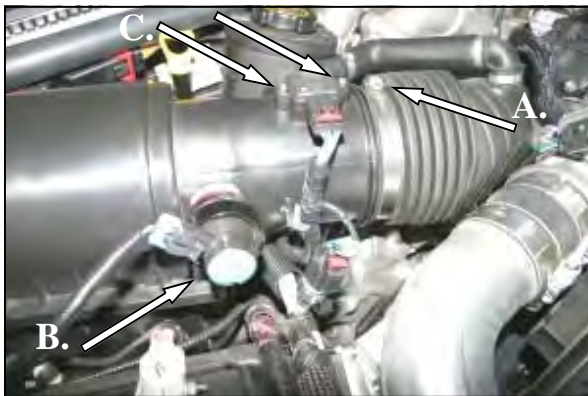

**1. Disconnect the negative battery cables.**  
**A)** Loosen the hose clamp that holds the intake tube to the airbox. **B)** Disconnect the filter minder wiring harness, and then remove the factory filter minder and grommet from the intake tube (save for reuse). **C)** Disconnect the Mass Air Flow (MAF) sensor wiring harness. Using the supplied Torx bit, remove the two screws, and the (MAF) sensor from the factory airbox. Save the MAF sensor for reinstallation in step #9.

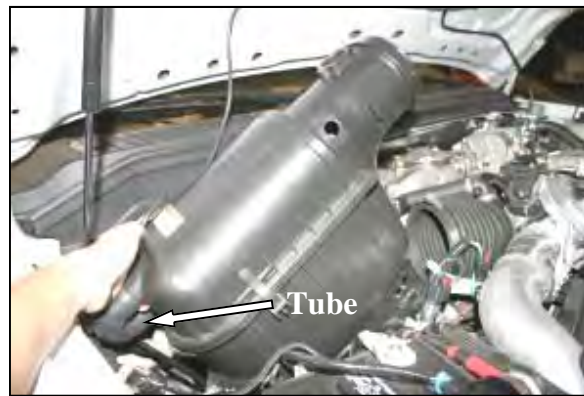

**2.** Remove the factory airbox and tube from the vehicle as an assembly, by pulling straight up on the box. It is only held in place by grommets, no bolts.



**3.** Remove one bolt from the factory airbox mounting plate, and save it for reinstallation in step #8.

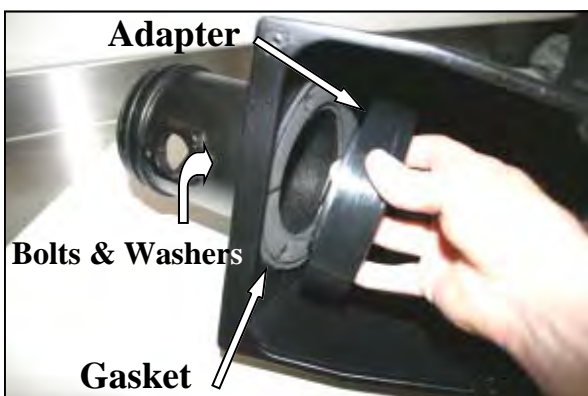

**4.** Install the adapter gasket (#13), and filter adapter (#4) into the Airaid Cool Air Box (#2) using three 1/4-20x5/8" hex bolts (#6), and 1/4" flat washers (#7).



**5.** Install the bracket (#12) using one 1/4-20x5/8" hex bolt (#6), 1/4" flat washer (#7), and 1/4-20 serrated nut (#8) as shown. Just snug the bolt for now, it will need to be adjusted in step #8.

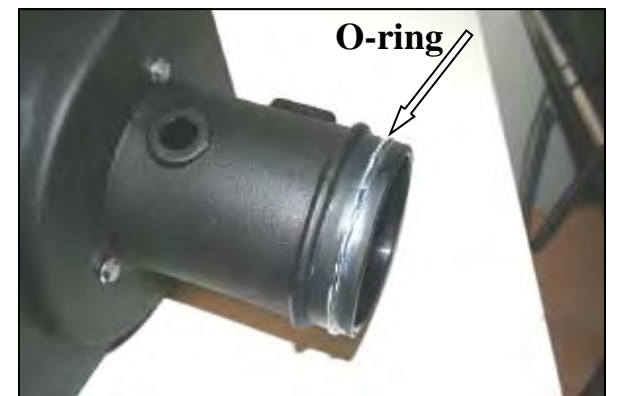

**6.** Install the O-ring (#14) into the groove on the Cool Air Box as shown. Apply a *light* coat of the supplied grease onto the O-ring.



**7.** Apply a *light* coat of the supplied grease onto the inside of the factory tube. Install the Airaid Cool Air Box into the vehicle making sure it is seated correctly into the factory grommets, and the inlet is aligned with the factory hole in the fender. Slide the factory intake tube over the O-ring and then tighten the factory hose clamp.

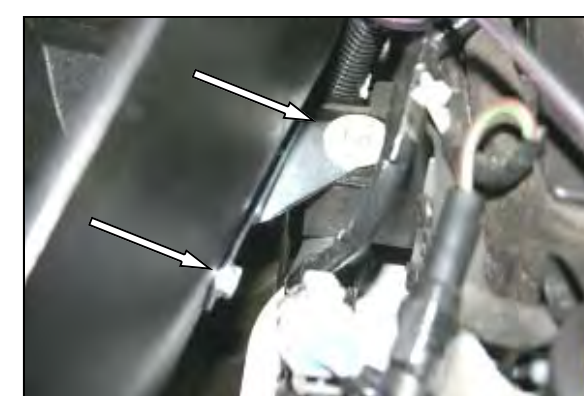

**8.** Reinstall the factory bolt that was removed in step #3, through the bracket that is bolted onto the side of the Cool Air Box. Adjust the box for fit, and tighten both bolts.

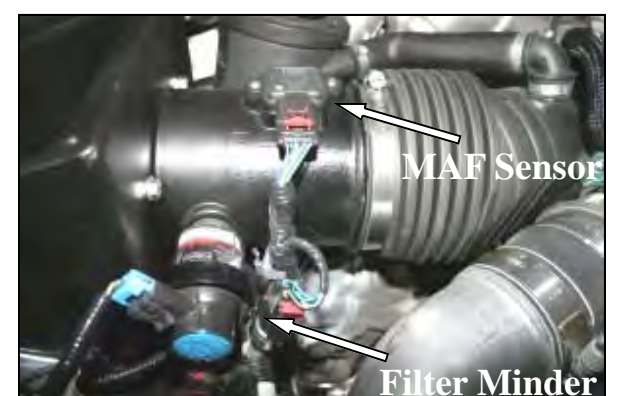

**9. A.)** Reinstall the factory grommet, and filter minder into the Cool Air Box, and then reconnect the filter minder wiring harness. **B.)** Reinstall the MAF sensor into the Cool Air Box using two 8-32x1/2" button head bolts (#9), as shown. Reconnect the MAF sensor wiring harness. **Do Not Use The Factory Screws!**





10. Install the Airaid Premium Filter (#1) onto the filter adapter, and tighten the hose clamp. Next install the Top Panel (#3) onto the top of the Cool Air Box using six 8-32x3/8" button head bolts (#10), and #8 flat washers (#11). Install the weather strip (#5) onto the edge of the top panel as shown.

**11. Double check your work!**

Make sure there is no foreign material in the intake path. Make sure all clamps, hoses, bolts, and screws are tight.

**12. Reconnect the negative battery cables!**

**Special Note:** In the unlikely event of a CEL (Check Engine Light) illuminating after the installation of your Airaid intake system, contact Airaid. It may not be necessary to take your vehicle to the dealer for service. We will be happy to speak to you about the issue.

*Before*



*After!*



Thank you for purchasing the Airaid Intake System. Contact Airaid @ (800) 498-6951 8:00 AM - 5:00 PM MST weekdays for questions regarding fit or instructions that are not clear to you. Your Airaid Intake System was carefully inspected and packaged. Check that no parts are missing, or were damaged during shipping. If any parts are missing, contact Airaid. The air filter element is protected from direct exposure to water and debris; care should be taken not to drive through deep water. WATER INGESTION IS THE DRIVERS RESPONSIBILITY! The air filter is reusable and should be cleaned using the Airaid Filter Tune-Up Kit periodically.

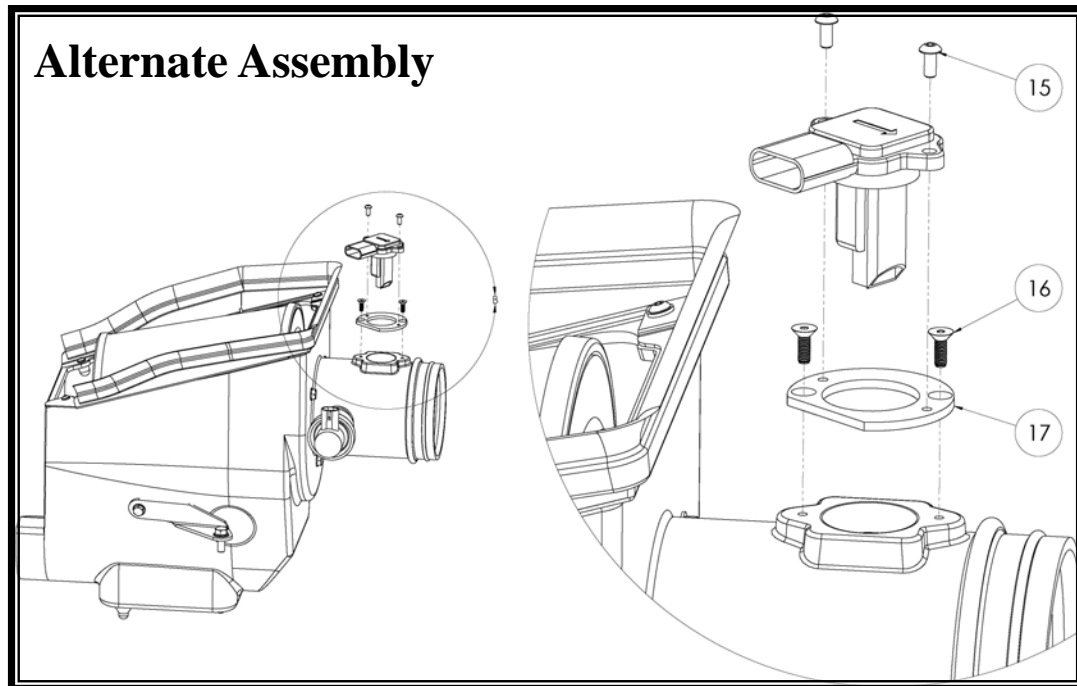

**Special Note:** Due to multiple factory mass air sensor calibrations, some vehicles may require the installation of the mass air flow sensor calibration plate and hardware as shown above. It may not be necessary to go to a dealer if your vehicle triggers a M.I.L. (Check Engine Light). Install the alternate assembly, or call Airaid for technical assistance.

**Don't Forget Your AIRAID Filter Tune-Up Kit!**



P/N 790-551 Aerosol Spray  
P/N 790-550 Squeeze Spray



Instructions Revision  
Date: 01/07/10