

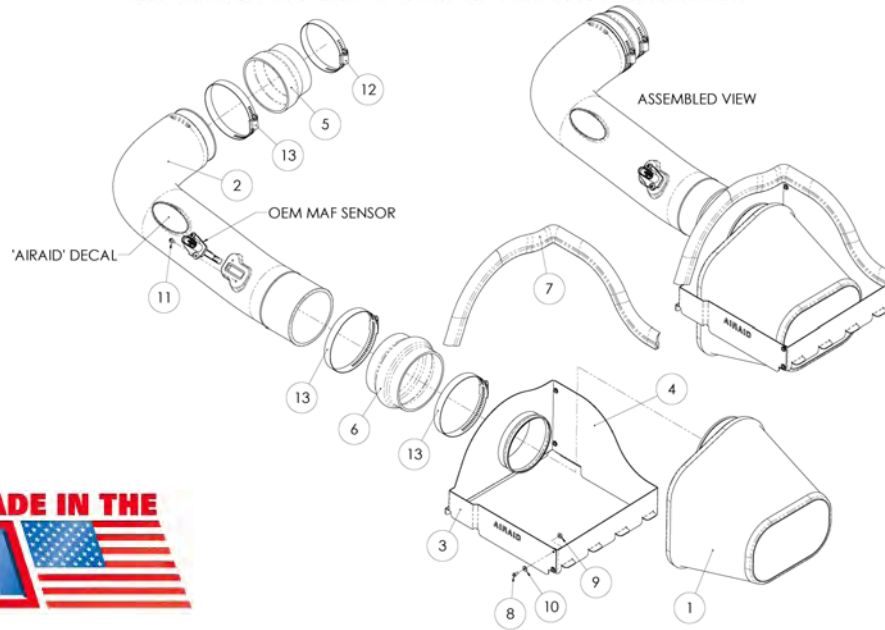

INTAKE SYSTEMS



Installation Instructions

Part Number 400-256
2008-2010 Ford F-250 5.4l
2008-2010 Ford F-350 5.4l

Packing List:

#1	720-478	Airaid Premium Filter	1
#2	KIT231EXT	Airaid Intake Tube	1
#3	KIT256 FPC	Front Panel	1
#4	KIT256RPC	Rear Panel	1
#5	KITRDCR10	Silicone Reducer Coupler	1
#6	KITHUMPHS25	Silicone Hump Hose	1
#7	KITWSTRIP02	Weather Strip 23"	1
#8	KITLOOM01	Split Loom 20"	1
	KIT256HP	Hardware & Instructions	1
#9	KIT6C31MXPPZ	6-32 x 5/16" Screw	4
#10	KIT6CNKEPZ	6-32 Keps Nut	4
#11	KIT6NWSAPZ	#6 Flat Washer	4
#12	KIT15BHC3038	8-32 x 3/8" Button Head Screw	2
#13	KITHS52	#52 Hose Clamp	1
#14	KITHS64	#64 Hose Clamp	3
#15	KITBIT#T20	T-20 Torx Driver	1

Tools Required For Installation:

3/32" Allen Wrench
 5/16", Socket
 Ratchet & Extension
 Phillips Screwdriver



1. Disconnect the negative battery cable!
 Loosen the two intake clamps, unclip the coolant hose and remove the Factory intake tube.

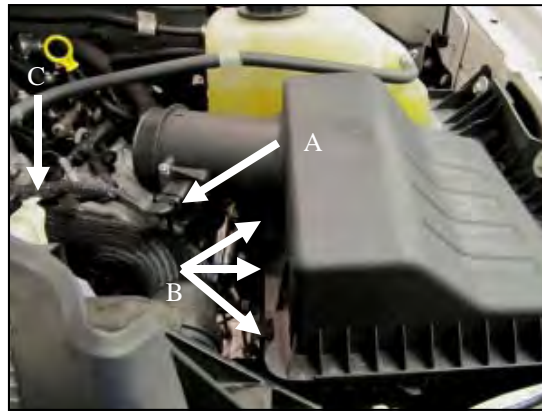

2. A.) Disconnect the Mass Air Flow (MAF) Sensor.
B.) Unfasten the three airbox clips on the left side, and remove the upper half of the factory airbox.
C.) Pull the wiring harness anchor out of the power steering reservoir.

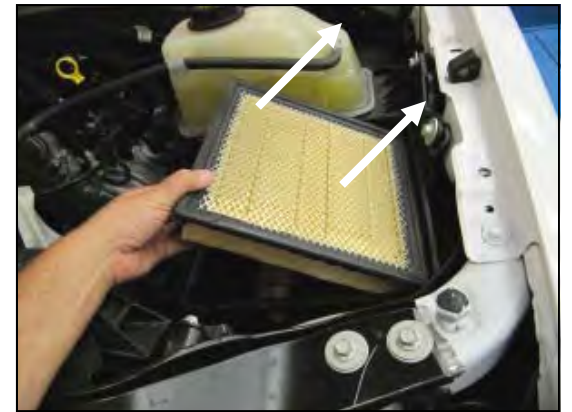

3. Remove the factory air filter from the lower half of the airbox.

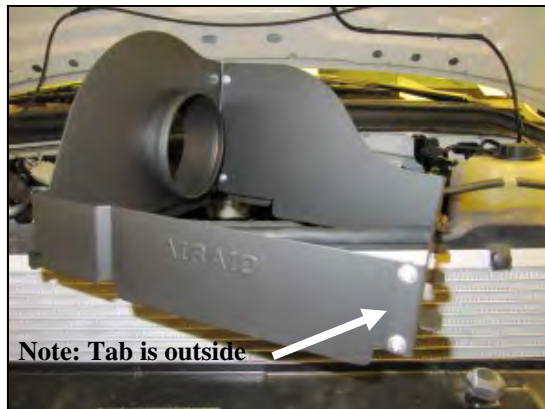

4. Assemble the two Quick Fit panels (#3 & #4) as shown using four 6-32 screws (#9) flat washers (#11) and keps nuts (#10).



5. A.) Install the Silicone Hump Hose (#6) and two #64 Hose Clamps(#14) onto the Quick Fit assembly. Leave the clamps loose for now.

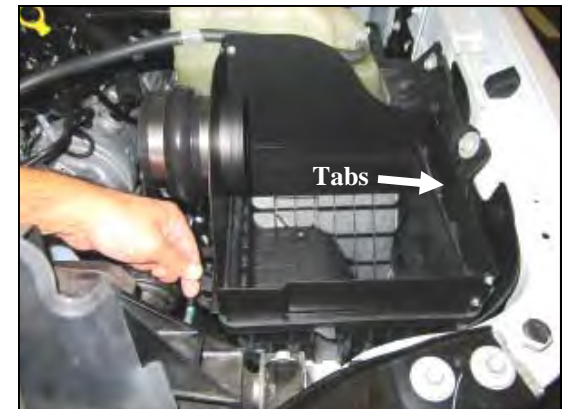

6. Install the assembly onto the lower half of the factory airbox. Slide the metal tabs into the airbox slots, and fastened the 3 airbox clips.



7. Install the Silicone Coupler (#5), one #64 Hose Clamp(#14), and the #52 Hose clamp (#13) onto the engine air inlet. Leave the clamps loose for now.



8. A.) Transfer the MAF sensor into the Airaid Intake Tube (#2) and secure using two 8-32 x 3/8" button head screws (#12). **Do Not Use The Factory Torx Head Screws !**



9. A.) Insert the Airaid Intake Tube into the couplers as shown. Check for alignment, and tighten all clamps.
B.) Slide the Split Loom (#8) over the coolant line
C.) Re connect the Mass Air Flow Sensor.



10. Install the Airaid Premium Filter (#1) to the mounting flange inside the quick fit assembly. Complete the installation by attaching the Weather Strip (#7) to the top of the panels as shown.

11. Double check your work!

Make sure there is no foreign material in the intake path. Make sure all clamps, hoses, bolts, and screws are tight. intake path. Make sure all clamps, hoses, bolts, and screws are tight. Periodically check the tightness of all hose clamps.

12. Re-connect the negative battery cable!

Before!



After!



Thank you for purchasing the Airaid Intake System. Contact Airaid @ (800) 498-6951 8:00 AM - 5:00 PM MST weekdays for questions regarding fit or instructions that are not clear to you. Your Airaid Intake System was carefully inspected and packaged. Check that no parts are missing, or were damaged during shipping. If any parts are missing, contact Airaid. The air filter element is protected from direct exposure to water and debris; care should be taken not to drive through deep water. WATER INGESTION IS THE DRIVERS RESPONSIBILITY! The air filter is reusable and should be cleaned using the Airaid Filter Tune-Up Kit periodically.

Don't Forget Your AIRAID Filter Tune-Up Kit!



P/N 790-551 Aerosol Spray
P/N 790-550 Squeeze Spray

Instructions Revision
Date: 09/15/10