

AIRRAID®

INTAKE SYSTEMS

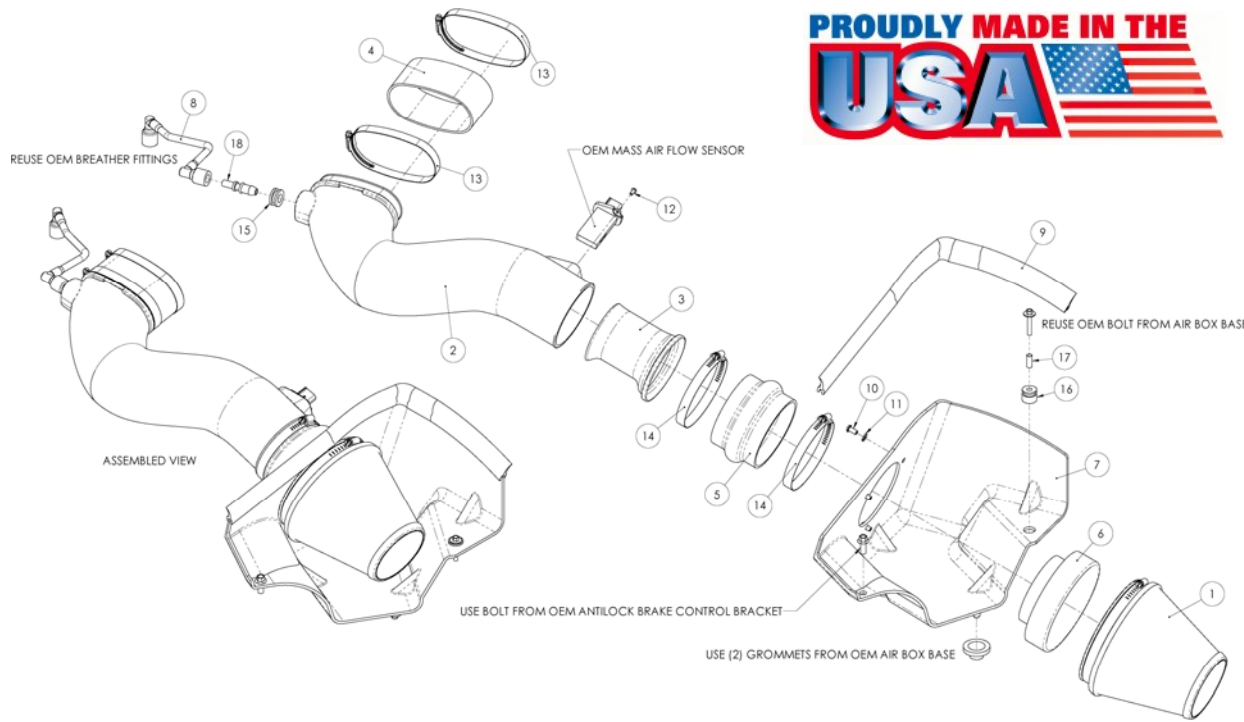

Installation Instructions
Part Number 450-172
2005-07 Ford Mustang GT
4.6L V-8

Packing List:

| | | | |
|-----|--------------|----------------------------|---|
| #1 | 700-466 | Airaid Premium Filter | 1 |
| #2 | KIT172T | Airaid Intake Tube | 1 |
| #3 | KIT172I | Modular Venturi Tube (MVT) | 1 |
| #4 | KITCOUPLER07 | Oval Coupler | 1 |
| #5 | KITHUMPHS05 | Hump Hose | 1 |
| #6 | KIT112MAFADA | Filter Adapter | 1 |
| #7 | KIT172CAD | Cool Air Dam | 1 |
| #8 | KITHOSE06 | 3/8"x12" Hose | 1 |
| #9 | KITWSTRIP03 | Weather Strip 22" | 1 |
| | KIT172HP | Hardware & Instructions | 1 |
| #10 | KIT15DHC3050 | 1/4-20 Button Head Bolt | 3 |
| #11 | KIT09FWX019 | 1/4" Flat Washer | 3 |
| #12 | KIT15BHC3038 | 8-32x3/8" Button Head Bolt | 2 |
| #13 | KITHS72 | #72 Hose Clamp | 2 |
| #14 | KITHS64 | #64 Hose Clamp | 2 |
| #15 | KITGRMT03 | Grommet | 1 |
| #16 | KITGRMT11 | Tall Grommet | 1 |
| #17 | KITSPACER02 | Aluminum Sleeve | 1 |
| #18 | KITFITTING05 | Aluminum Fitting | 1 |
| | KITBIT01 | #20 Torx Bit | 1 |

Tools Required For Installation:

5/32" Allen Wrench & 3/32" Allen Wrench
 5/16" Socket & 10mm Socket
 Ratchet & Extension



1. Disconnect negative battery cable.
PLEASE READ #22 ON THE BACK PAGE!!
 Push the green plastic tabs, and remove breather hose from vehicle. (Save for later use).



2. Loosen the intake tube hose clamp on the throttle body. Slide the red tab on the electrical connector, and disconnect the mass air sensor.



3. With a 10mm socket, remove the bolt holding the factory airbox to the fender, and save it for re-installation in step #8.

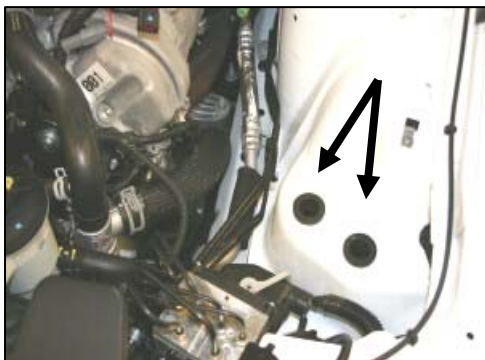

4. Remove the complete factory intake. Use caution to retain the factory grommets in the inner fender.

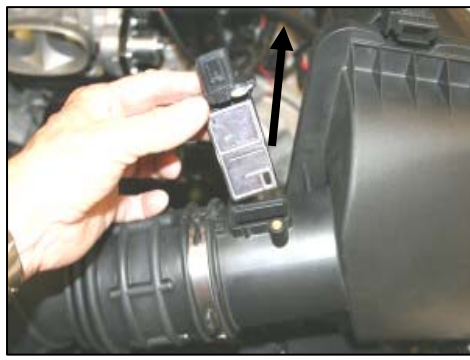

5. Using the provided #20 torx bit, remove two screws and the mass air sensor from the factory airbox lid. Note the direction of the sensor for proper re-installation later. (Save the mass air sensor for re-installation in step #13, the factory screws will not be re-used).



6. With a 10mm socket, remove and save the bolt from the anti-lock brake bracket. It will be re-installed later in step #9.



7. Install the provided grommet (#16), with the groove at the top, into the Cool Air Dam (CAD) hole, as shown. Next slide the aluminum sleeve (#17), into the center of the grommet.



8. Install the air filter adapter (#6) into the Cool Air Dam (#7) as shown, using 3 button head bolts (#10) and 1/4" flat washers (#11).



9. Install the CAD into the factory grommets in the inner fender, and re-install the bolts from steps #3 and #6.



10. Install the hump hose (#5) on the filter adapter (#6), with two #64 hose clamps (#14). Tighten only the clamp next to the CAD.



11. Install the supplied grommet (#15) and aluminum fitting (#18) into the Airaid intake tube as shown.



12. Install the Modular Venturi Tube (MVT) (#3) into the Airaid Intake Tube (#2) as shown. **Option: For additional air flow, delete the MVT. This requires custom computer programming. Engine damage will result without the use of custom tuning. (SEE #22 BELOW!!)**



13. Align the two slots in the tubes, and install the factory mass air sensor removed, and install #5. Make sure the screw holes line up, then install the two supplied button head screws. (#13). **DO NOT USE THE FACTORY SCREWS!!**



14. Install the oval coupler (#4) with two #72 hose clamps (#13). Tighten only the clamp closest to the aluminum fitting. (*Hint: For a clean look, locate the tightening screws under the tube*)!



15. A.) Install the tube into the hump hose. B.) Now slide the oval coupler onto the throttle body. Tighten the remaining two hose clamps, and re-connect the mass air sensor, from step #2.



16. Install the Airaid Premium Filter (#1) onto the filter adapter, and tighten the clamp. Install the weather strip (#9) on the top of the CAD as shown.



17. **VERY CAREFULLY!** With a razor blade, cut the plastic tube off both of the factory breather hose ends as shown.



18. Install the 3/8"x12" hose (#8) onto the factory breather ends as shown.



19. Re-connect the breather line (#8) back to the factory locations as shown.

20. Double check your work!

Make sure there is no foreign material in the intake path. Make sure all clamps, hoses, bolts, and screws are tight. Double check the hood clearance!

21. Reconnect the negative battery cable!

22. Off the shelf aftermarket REPROGRAMMERS (Superchips, Hypertech, etc.) DOES NOT constitute "Custom Tuning", therefore the MVT should NOT be removed. Custom tuning is for modified vehicles, (increased compression, headers, camshaft, and / or rear axle ratio change etc.) NOT for "stock" vehicles with a programmer or "chip". Custom tuning is vehicle specific tuning, for that vehicle and it's unique modifications. In other words, it is ONE OFF programming. Since this tuning is unique to each vehicle, AIRAID can not offer any assistance regarding any issues that may occur.

Thank you for purchasing the Airaid Intake System. Contact Airaid @ (800) 498-6951 8:00 AM - 5:00 PM MST weekdays for questions regarding fit or instructions that are not clear to you. Your Airaid Intake System was carefully inspected and packaged. Check that no parts are missing, or were damaged during shipping. If any parts are missing, contact Airaid. The air filter element is protected from direct exposure to water and debris; care should be taken not to drive through deep water. WATER INGESTION IS THE DRIVERS RESPONSIBILITY! The air filter is reusable and should be cleaned using the Airaid Filter Tune-Up Kit periodically.

Before!



After!



Don't Forget Your AIRAID Filter Tune-Up Kit!



P/N 790-551 Aerosol Spray
P/N 790-550 Squeeze Spray



Instructions Revision
Date: 08/24/06