

AIR AID®

INTAKE SYSTEMS

Installation Instructions
Part Number 451-177
2005-09 Ford Mustang
4.0L V-6

Packing List:

#1	701-466	Airaid Premium Filter	1
#2	KIT177T	Airaid Intake Tube	1
#3	KITRDCR05	3 1/2" to 3" x 2 1/2" Reducer	1
#4	KITHUMPHS05	Urethane Hump Hose	1
#5	KIT1121MAFADA	Filter Adapter	1
#6	KIT172CAD	Cool Air Dam	1
#7	KITWSTRIP03	Weather Strip 22"	1
	KIT177HPS	Hardware & Instructions	1
#8	KIT15DHC3050	1/4-20 Button Head Bolt	3
#9	KIT09FWZ019	1/4" Flat Washer	5
#10	KIT15BHC3038	8-32 x 3/8" Button Head Bolt	2
#11	KITHS48	#48 Hose Clamp	1
#12	KITHS52	#52 Hose Clamp	1
#13	KITHS72	#72 Hose Clamp	2
#14	KIT25C87HCSS	1/4-20 x 7/8" Hex Bolt	1
#15	KIT25CNNES	1/4" Nylock Nut	1
#16	KITGRMT10	Grommet	1
#17	KITGRMT11	Tall Grommet	1
#18	KITSPACER02	Aluminum Sleeve	1
	KITBIT#01	#20 Torx Bit	1

Tools Required For Installation:

5/32" Allen Wrench & 3/32" Allen Wrench
5/16", 7/16", & 10mm Socket
Ratchet & Extension
7/16" Wrench
Side Cutters

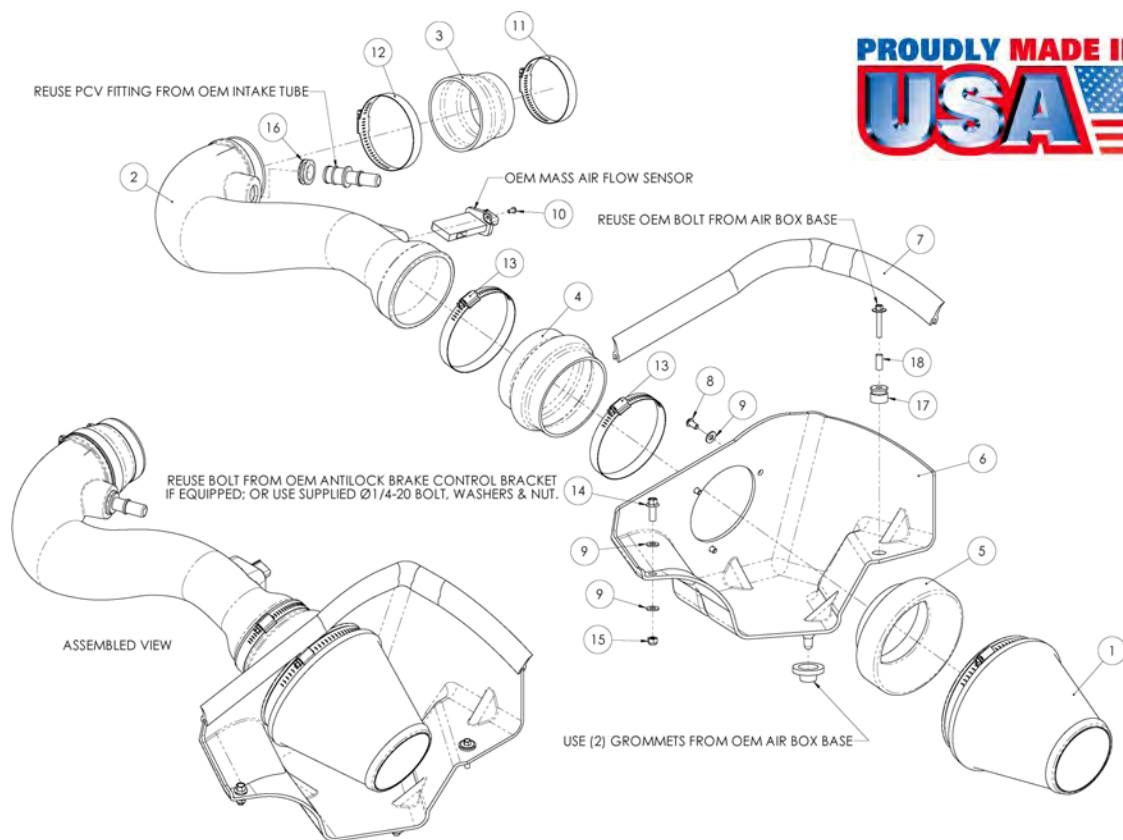

1. **Disconnect negative battery cable.**
A) Loosen hose clamp on throttle body.
B) Push green tab, and disconnect breather hose at the factory intake tube.
C) Slide red tab, and disconnect the Mass Air Flow sensor wiring harness.

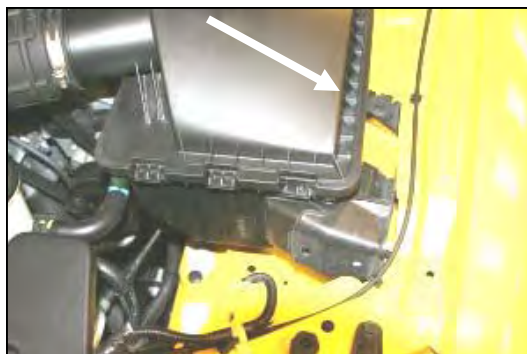

2. Remove bolt that holds the factory airbox to the fender. (Save bolt for later use in step #7).



3. Remove the complete intake system as an assembly.

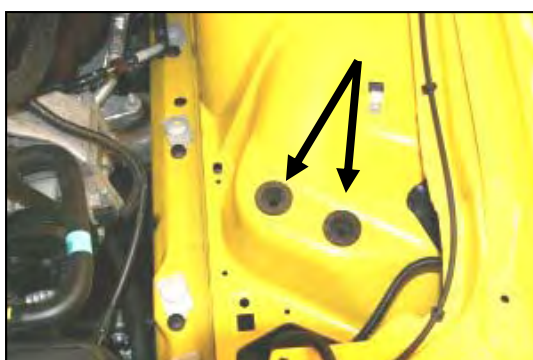

4. Make sure that you retain the factory grommets in the inner fender from the bottom of the factory airbox.



5. Using the supplied #20 torx bit, remove 2 factory screws, and remove the MAF sensor from the factory tube. (Save the MAF sensor for reinstallation in step #12).



6. With a pair of side cutters, remove the metal band that holds the plastic breather fitting in the factory tube. Next remove the fitting from the tube, and save it for reinstallation in step #11.



7. Install the tall grommet (#17), (groove at the top), into the Cool Air Dam (#6), and then slide the aluminum sleeve (#18) into the grommet as shown. Install the CAD through the 2 factory grommets in the fender and reinstall the factory bolt from step #2.

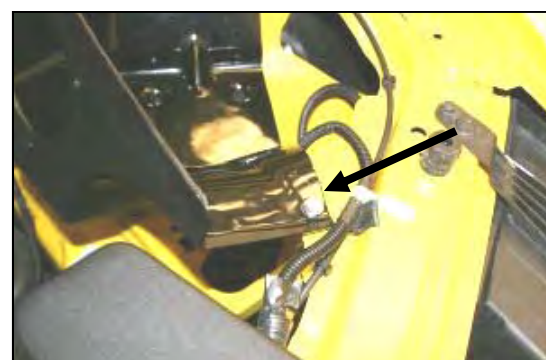

8. If your vehicle has the optional anti-lock brakes, remove the bolt from the bracket under the CAD, and reinstall it through the hole in the front of the CAD. (See arrow). If your vehicle does not have this bracket, install the supplied 1/4" bolt (#14), two 1/4" washers (#9), and 1/4" Nylock nut (#15) through the CAD and sheet metal, and tighten.

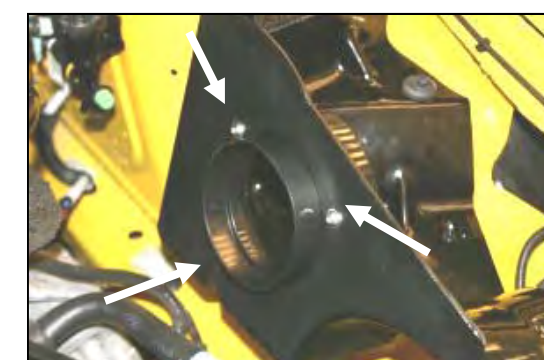

9. Install the filter adapter (#5) into the CAD using three button head bolts (#8), and washers (#9).



10. Install the supplied grommet (#16), into the Airaid Intake Tube (#2)

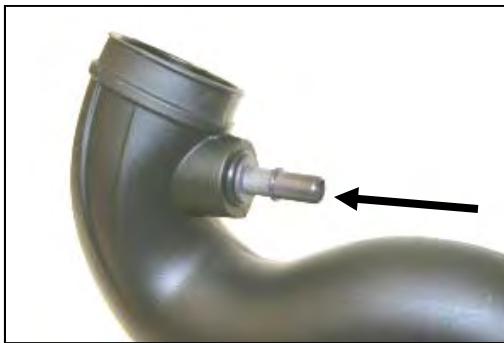

11. Install the factory fitting from step #7 into the grommet (#16) from step #10.



12. Install the MAF sensor from step #5 into the Airaid Intake Tube. Use the two supplied 8-32 button head bolts (#10), to securely fasten the MAF sensor.
Do Not Use The Factory Screws!



13. Install the urethane hump hose (#4) on the filter adapter (#5) with two #72 hose clamps (#13). Next install the reducing coupler (#3) small end first, onto the throttle body with one #48 hose clamp (#11), and one #52 hose clamp (#12). Leave clamps loose.



14. Install the Airaid Intake Tube into the hump hose first, and then into the reducing coupler, adjust for fit, and then tighten the four hose clamps. Reconnect the breather hose, and the wiring harness to the MAF sensor.



15. Install the Airaid Premium Filter (#1) onto the filter adapter (#5). Next install the weather strip (#7) on the top of the CAD as shown. Start at the front of the CAD and work towards the rear.

16. Double check your work!

Make sure there is no foreign material in the intake path. Make sure all clamps, hoses, bolts, and screws are tight. Double check the hood clearance.

17. Reconnect the negative battery cable!

Before!



After!



SynthaMax®

Do Not Oil



Synthamax Air Filters do not require oil. Service air filter as needed by cleaning with common non-petroleum all-purpose household cleaner and water. Simple Green®, Formula 409® or equivalent works great. Apply cleaner to outside of air filter and allow to soak. Then flush filter clean from the inside out with a garden hose and repeat steps if necessary. Do not apply high pressure water or air to clean filter. Allow filter to air dry and reinstall.