

AIRRAID[®]

INTAKE SYSTEMS

520-130 INSTALLATION INSTRUCTIONS

00-04 Nissan Frontier/Xterra 3.3L

Thank you for purchasing the **AIRRAID Intake System**. Please read the instruction manual carefully before proceeding with the installation. Contact **AIRRAID** (480-443-3333) 8:00 AM - 5:00 PM MST weekdays) for questions regarding fit or instructions that are not clear to you. Your **AIRRAID Intake System** was carefully inspected and packaged. Check that no parts are missing, or were damaged during shipping. If any parts are missing, please contact **AIRRAID**. The air filter element is protected from direct exposure to water and debris in its new location. Care should be taken not to drive through deep water. **WATER INGESTION IS THE DRIVERS RESPONSIBILITY!** The conical air filter is washable oiled cotton gauze. It is a lifetime element. A cleaner kit is offered for servicing the air filter element.

Thank you for selecting AIRRAID.



AIRRAID Packing List

720-130	Filter	1
KIT130RRC	Rear Dam	1
KIT130MAFC	Top Dam	1
KIT130WS	Weather Seal	1
KIT130TFC	Tube	1
KIT130HP	HARDWARE PACK	1
Instruction Sheet		x1
KIT130G	Gasket	x1
KIT130L	Dam Extension	x1
KIT130FILTER	PCV Line Filter	x1
KIT6C31MXPPZ	6-32x5/16 Screw	x5
KIT6CNKEPZ	6-32 Keps Nut	x5
KIT6NWSAPZ	#6 Flat Washer	x5
KIT25C87HCSS	1/4-20x7/8 Hex Bolt	x4
KIT09FWZ019	3/16 USS Washer	x8
KIT25CNNES	1/4-20 Lock Nuts	x4

Tools Required for Installation

Ratchet Wrench
 10mm Socket
 5/16" Socket or Nut Driver
 1/2" Socket
 1/2" Wrench
 6" Socket Extension
 Flat Blade Screwdriver
 Pliers

Installation Instructions. Read Me!

- 1) **DISCONNECT NEGATIVE (-) BATTERY CABLE.**
- 2) Remove air box top lid.
 - a) Loosen hose clamp at Mass Air Flow (M.A.F.) meter and airbox lid. **See FIG. #1**
 - b) Disconnect MAF sensor wire.
 - c) Unclip air box lid.
 - d) Remove lid and filter from vehicle. Set aside for later modification. **See FIG. #2**
- 3) Remove, modify and replace air box base.
 - a) Unbolt three 10mm bolts that fasten the air box base and remove base from vehicle.
 - b) Remove and discard tube from air box base. **See FIG #3**
 - c) Remove insulation pad from air box base. Use a pliers to remove the securing clips. **See FIG #4**
 - d) Replace modified air box base in vehicle.
- 4) Assemble **AIRAID**.
 - a) Unbolt MAF from air box lid. **See FIG#5**
 - b) Assemble the two AirAid dams using the hardware provided. **See FIG#6, 6a, 8**
 - c) Position and bolt the MAF and Filter Adapter Tube onto the AirAid dam with the supplied gasket and hardware. **See FIG# 6,6a, 9**
 - d) Position air filter on to adapter. Finger tighten for now.
- 5) Install **AIRAID**.
 - a) Position over air box base. Rotate filter as necessary to clear air box base. Snap onto base.
 - b) (Skip this step for 2001 and earlier models) Install the dam extension using the hardware provided as shown. See FIG# 7, 7a
 - c) Reconnect MAF to inlet tube and tighten clamp.
 - d) Reconnect MAF wire harness.
 - e) Press weather seal onto air dam.
- 6) Finishing up **AIRAID** Installation.
 - a) Check for any foreign objects in the air flow path.
 - b) Reconnect battery cable. Double check your work.

Note: If your vehicle is equipped with a breather hose that is disconnected after installation, insert the small filter provided into the hole in the cold air dam (on the filter side of the dam). Secure hose to the nipple on the filter that is protruding through the panel.

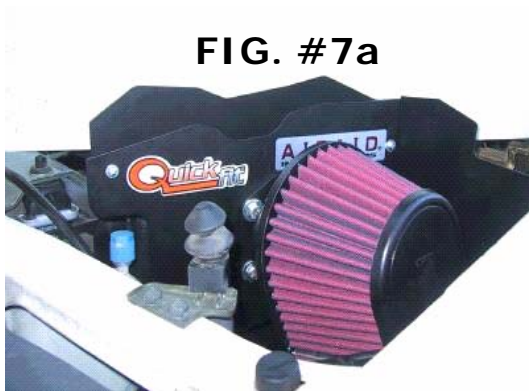

FIG. #1



FIG. #2





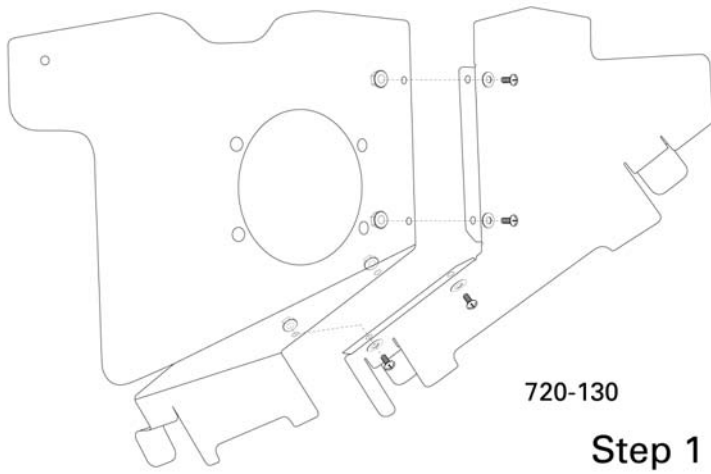

FIG. #8

720-130

Step 1

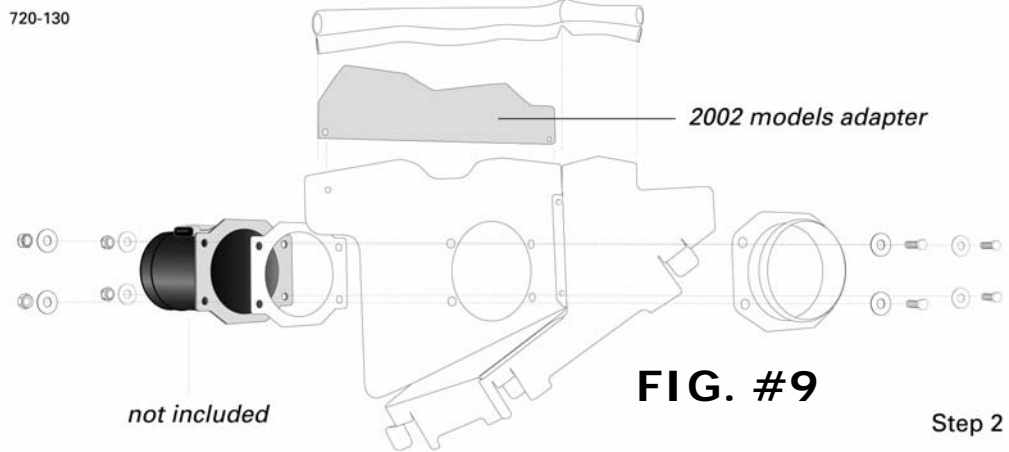
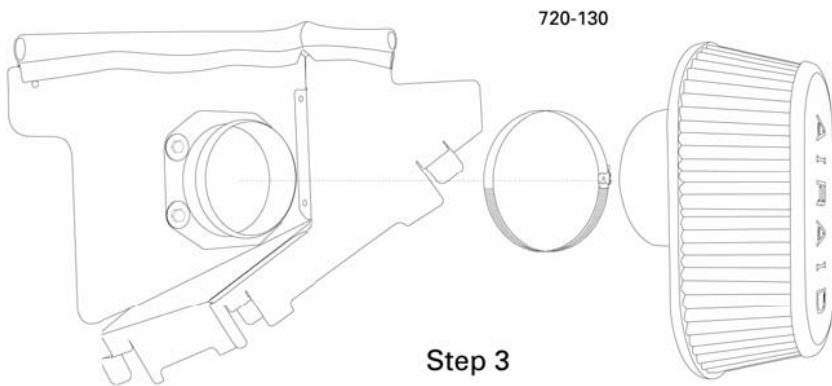

FIG. #9

Step 2



Step 3



AIRAID Intake Systems
 Model No. - 200-102, 200-103, 200-104, 200-108, 200-112, 300-106, 300-107, 300-117, 310-110, 400-109, 400-113, 400-114, 400-115, 400-116, 400-118.

CARB E.O. No. D-520
Evergreen Performance
 Scottsdale, AZ

AIRAID
 INTAKE SYSTEMS
 This Intake Part Has Been Granted
 CARB E.O. No. D-520 And Is Legal For
 Sale And Use In California

WARNING: This Label Must Be Attached
 In A Readily Visible Location Under
 Your Vehicle's Hood!

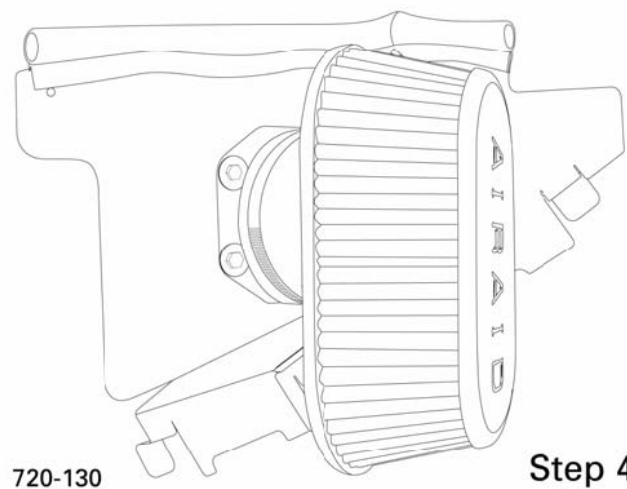

720-130

Step 4