

AIRRAID®

INTAKE SYSTEMS

Installation Instructions
Part Number 520 - 152
2004-13 Nissan Titan / Armada
2004-2010 Infiniti QX56
5.6L V-8

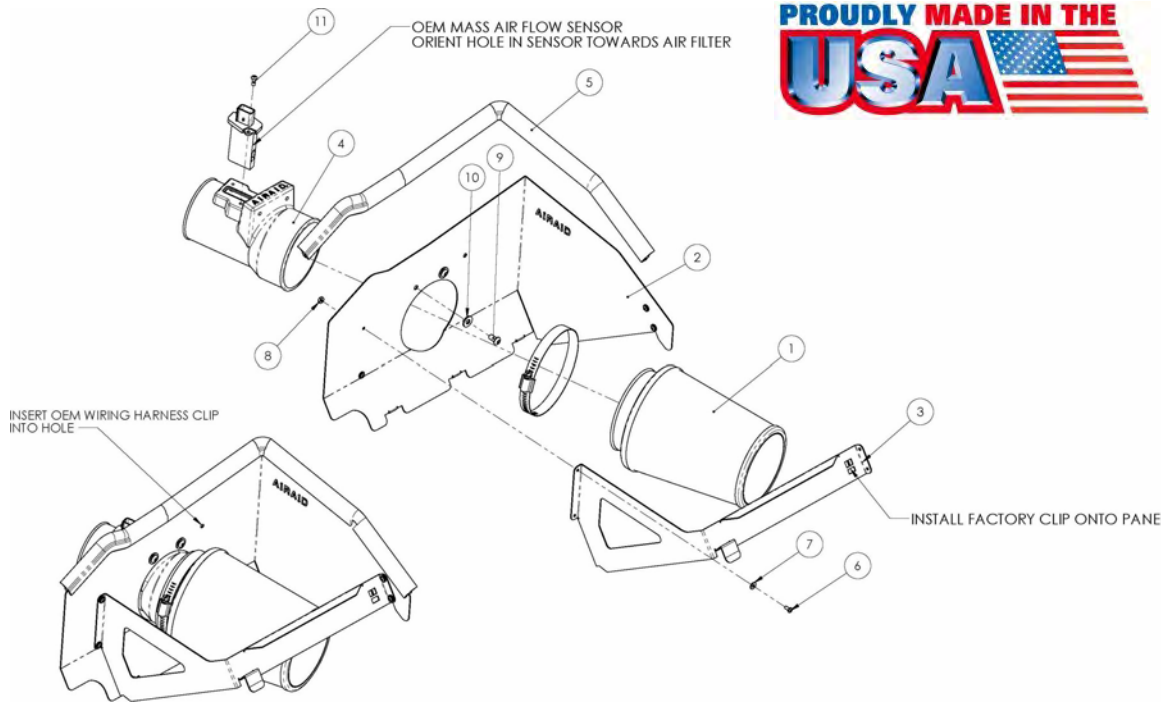

Packing List:

#1	700-458	Airaid Premium Filter	1
#2	KIT152MAFC	MAF Panel	1
#3	KIT152FPC	Front Panel	1
#4	KIT152A	Air Filter Adapter	1
#5	KITWSTRIP02	Weather Strip 27"	1
	KIT152HP	Hardware & Instructions	1
#6	KIT6C31MXPPZ	6-32 x 5/16" Screw	4
#7	KIT6NWSAPZ	#6 Flat Washer	4
#8	KIT6CNKEPZ	6-32 Keps Nut	4
#9	KIT15DHC3050	1/4-20 x 1/2" Button Head Bolt	2
#10	KIT09FWZ019	1/4" Flat Washer	2
#11	KIT15BHC3050	8-32 x 1/2" SS Button Screw	2

Tools Required For Installation:

Flat Head Screwdriver
 Phillips Head Screwdriver
 10mm socket
 3/32", 5/32" Allen Wrench

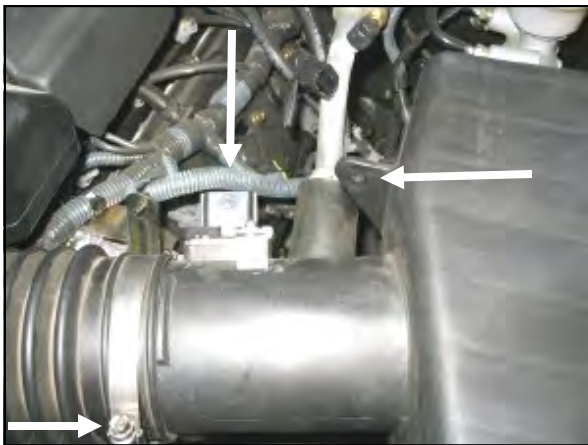

1. Disconnect the negative battery cable.

Loosen the hose clamp on the factory intake tube. Disconnect the Mass Air Flow (MAF) sensor wiring harness from the sensor, and unclip the harness from the air box lid.

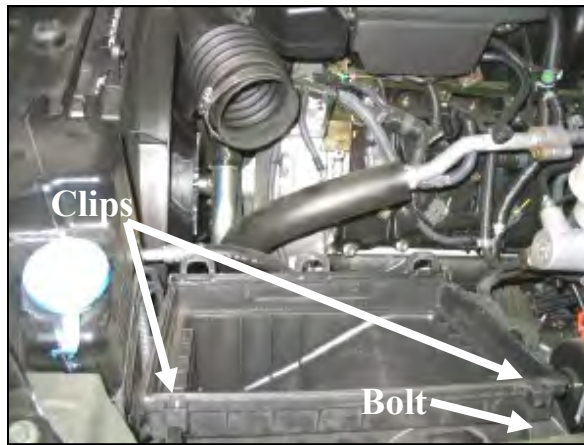

2. Unclip the factory air box lid from the factory air box base, and remove it from the engine compartment. Remove the factory air filter from the air box base. Using a 10mm socket, remove two bolts (three on some vehicles) from the air box base (save for reuse).



3. Using a Phillips head screwdriver, remove two screws and the MAF sensor from the factory air box lid. Save the sensor for reuse.

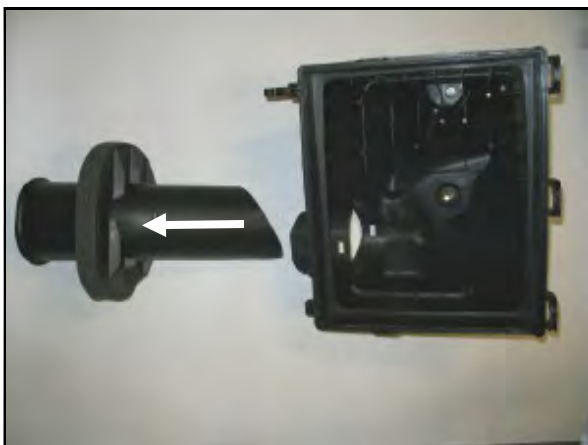

4. Remove the factory air box base from the vehicle. Using a flat blade screwdriver, unsnap and remove the factory tube from inside the air box base. Re-install the factory air box base and the bolts into the vehicle, without the tube.

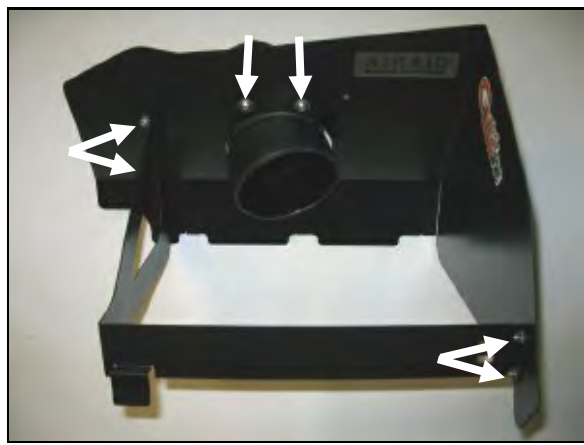

5. Assemble the Airaid Quick Fit Panels (#2, #3) using four 6-32 x 5/16" screws (#6), #6 flat washers (#7), and 6-32 keps nuts (#8). Next, install the air filter adapter (#4) using two 1/4-20 x 1/2" button head bolts (#9), and 1/4" flat washers (#10).



6. Using two 8-32 x 1/2" SS button head screws (#11), reinstall the factory MAF sensor into the air filter adapter.



7. Remove the clip from the factory air box lid and install it in the Quick Fit Panels as shown.



8. Install the Quick Fit Panel assembly onto the factory air box base using the factory clips. Slip the factory intake tube over the air filter adapter, and then tighten the factory hose clamp.



9. Reconnect the MAF sensor wiring harness to the sensor. Mount the factory wiring harness clip into the hole in the Airaid Quick Fit panel.



10. Install the Airaid Premium Filter (#1) onto the air filter adapter, and tighten the hose clamp. Install the weather strip (#5) onto the Quick Fit Panels as shown (*Note: Start at one corner and work your way around to the end to insure proper alignment of the weather strip*).

11. Double check your work!

Make sure there is no foreign material in the intake path. Make sure all clamps, hoses, bolts, and screws are tight.

12. Reconnect the negative battery cable!

Included with your Airaid Intake System is a sticker with a California Air Resources Board (C.A.R.B.) Executive Order (EO) number. This sticker must be placed in plain view inside of the engine compartment. Failure to do so may prevent you from passing a smog inspection.

Before



After!



Thank you for purchasing the Airaid Intake System. Contact Airaid @ (800) 498-6951 8:00 AM - 5:00 PM MST weekdays for questions regarding fit or instructions that are not clear to you. Your Airaid Intake System was carefully inspected and packaged. Check that no parts are missing, or were damaged during shipping. If any parts are missing, contact Airaid. The air filter element is protected from direct exposure to water and debris; care should be taken not to drive through deep water. WATER INGESTION IS THE DRIVERS RESPONSIBILITY! The air filter is reusable and should be cleaned using the Airaid Filter Tune-Up Kit periodically.

Don't Forget Your AIRAID Filter Tune-Up Kit!



P/N 790-551 Aerosol Spray
P/N 790-550 Squeeze Spray



Instructions Revision
Date: 01/17/13