



PART # 10502 SC

1999- 2003 FORD SUPER CREW

** Please refer to drawings on the back of this sheet **

Thank you for choosing the Backrack for your truck. The Backrack kit consists of the Backrack frame and the Hardware kit. The Hardware kit includes all required fasteners and one pair of Railmount Brackets.

The Backrack is secured to the bedrails of your truck with four Railmount Bolts. Because your truck has no stakepockets you will have to drill two 7/16" diameter holes through the bed rail on each side of the truck.

Step 1 : Attach the Railmount Brackets to the Backrack Frame.

- 1) Open the tailgate and lay the Backrack frame on the tailgate with deacis facing up.
- 2) Slide Railmount Brackets on each end of bottom tube so oblong slots align with holes.
- 3) Secure to rack frame using 1/2" x 3-1/2" Bolt, 1/2" lw, and 1/2" fw. Refer to Detail A.
- 4) Do not tighten fasteners at this time. Keep loose for adjustment later in installation.

Step 2: Place Backrack behind truck cab and mark layout holes for drilling.

- 1) Place Backrack behind the cab with the Railmount Brackets sitting on the bedrail.
- 2) Holes must be drilled only where you have access to the under side of the bedrail.
- 3) Once you have found a position where you can drill a hole and insert the Railmount bolt up through the bedrail without interference, you can mark the holes with a marker.
- 4) Remove Backrack and drill 7/16" diameter holes where you marked them.

Step 3: Fasten Backrack to the Truck Bed Rails.

- 1) Now that you have drilled your holes, you can fasten the Backrack to the bed rails.
- 2) Apply pieces of the black rubber pad to the bottom of the Railmount Brackets to protect paint.
- 3) Place Backrack with Railmount Brackets attached over holes drilled in bed rail.
- 4) Insert Railmount Bolts up through Bed rail and Railmount Bracket.
- 5) Secure with 3/8" nut, lock washer and flat washer.
- 6) Tighten 3/8 fasteners until lock washer compresses. The rectangle tab on the Railmount Bolt will keep the bolt from spinning when tightening.

Step 4: Center the Backrack behind the cab and tighten bolts.

- 1) Stand at the rear of the truck and center the Backrack behind the cab.
- 2) Finish the installation by tightening all nuts and bolts. We recommend using a ratchet handle extension when tightening the 1/2" x 3-1/2" bolt assembly to ensure maximum strength and rigidity.

Contact us @
905-849-3633 or 1-800-265-8137. Fax 905-849-4116. E mail: mfg@backrack.ca
WEBSITE: www.backrack4trucks.com

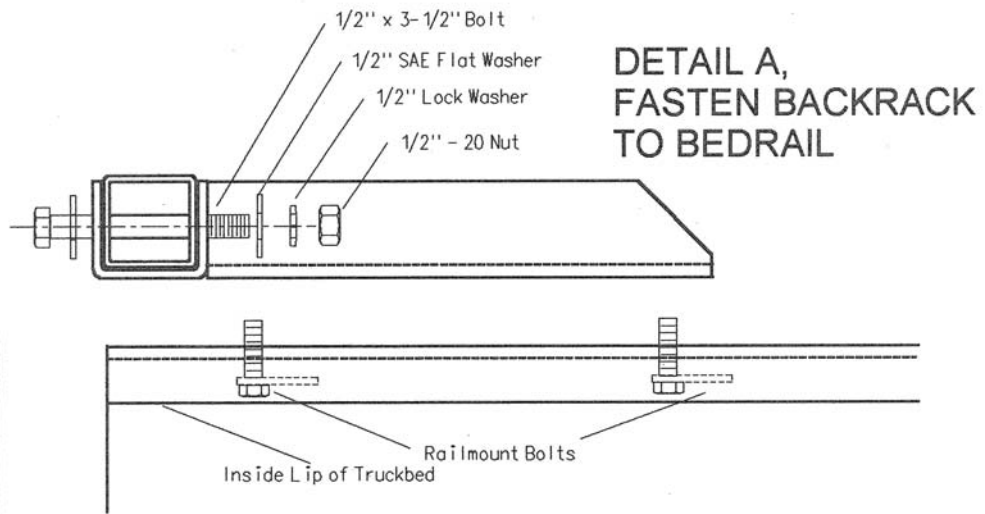

**VIEW OF PASSENGER SIDE, BEDRAIL
FROM REAR OF TRUCKBED (Below)**

