



# Supertop Replacement Top with Tinted Side and Rear Windows Installation Instructions



**For: Wrangler TJ 1997 – 2002**  
Does Not Include Hardware

**Part Number: 55629**

*This product is only designed for the vehicles listed above. DO NOT INSTALL THIS PRODUCT ON ANY VEHICLE OTHER THAN THOSE LISTED ABOVE. Failure to install this product on the proper vehicle could cause injury to the vehicle occupants and damage to the product.*

**Replacement for:**

- 51609 – Top Deck, Side Panels and Rear Curtain Only
- 51700 – Top Deck, Side Panels and Rear Curtain Only
- 51703 – Top Deck, Side Panels and Rear Curtain Only

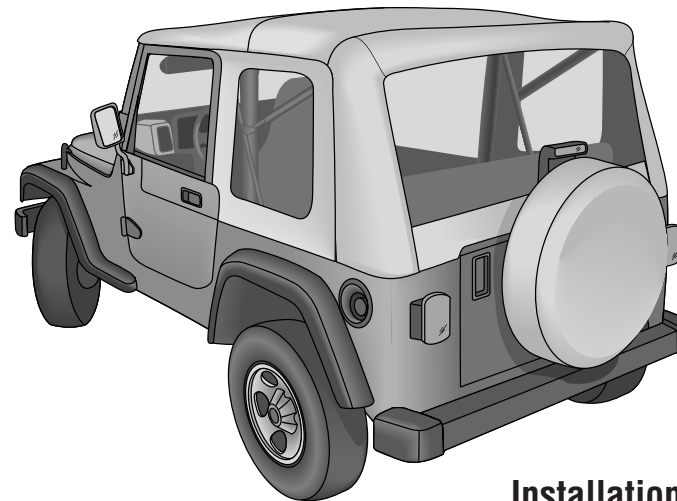

## Installation Tips

*Before you begin installing this top assembly, read all instructions thoroughly. After completing the installation, keep these instructions for further reference. Below are a few tips to make this installation easier.*

**For a smooth fit:**

For ease in installation, the top should be installed at temperatures above 72° F. Below this temperature, the fabric may contract an inch or more, making it difficult to fit to the vehicle.

It is normal for a top to contract and wrinkle when stored in the shipping carton. Within a few days after the installation, the top will relax and the wrinkles will disappear.

**0405 Rev. A**



## WARNING

This product is designed to enhance the appearance of the vehicle. Do not rely in any way on the components of this product to contain occupants within the vehicle, or to protect against injury or death in the event of an accident. Never operate vehicle in excess of manufacturer's specifications.

### WEAR SEAT BELTS AT ALL TIMES

Read and follow, precisely, all installation instructions provided when installing this product. Failure to do so could place occupants of the vehicle in a potentially dangerous situation. After installing or reinstalling, check to make sure it has been properly installed.

## Parts List

Fabric Top	Qty - 1	Quarter Widow, Left	Qty - 1
Quarter Widow, Right	Qty - 1	Rear Window	Qty - 1



## Caution

Safety glasses should be worn at all times while installing this product.

## Installing the Replacement Top

### Step One

#### INSTALL RETAINER IN WINDSHIELD CHANNEL

Remove the old top. Set the Tailgate Bar aside to be used later in Step Five.

Locate the top and orient it on the vehicle. Drape the top over the bows and insert the plastic strip sewn along the front of the top into the windshield retainer. Do not catch the fabric in the retainer. Center the front of the deck on the vehicle so that it is an equal distance from the top of the windshield flange on both sides.

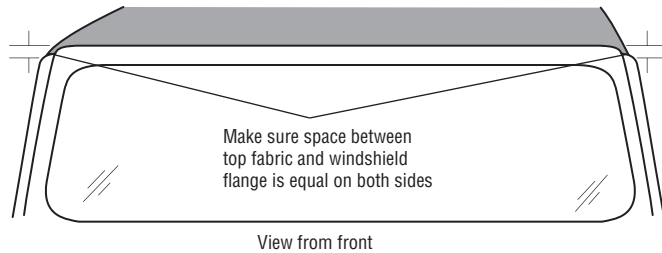
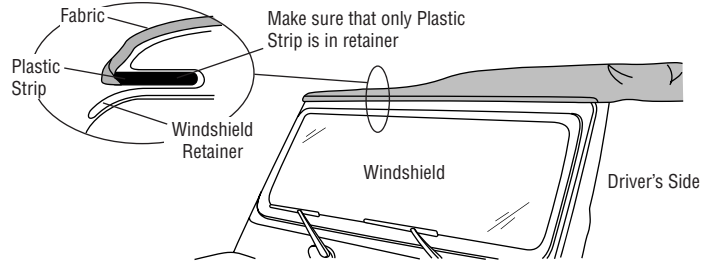

**Note:** For best possible installation, check to make sure that the soft top is perfectly centered on the vehicle.

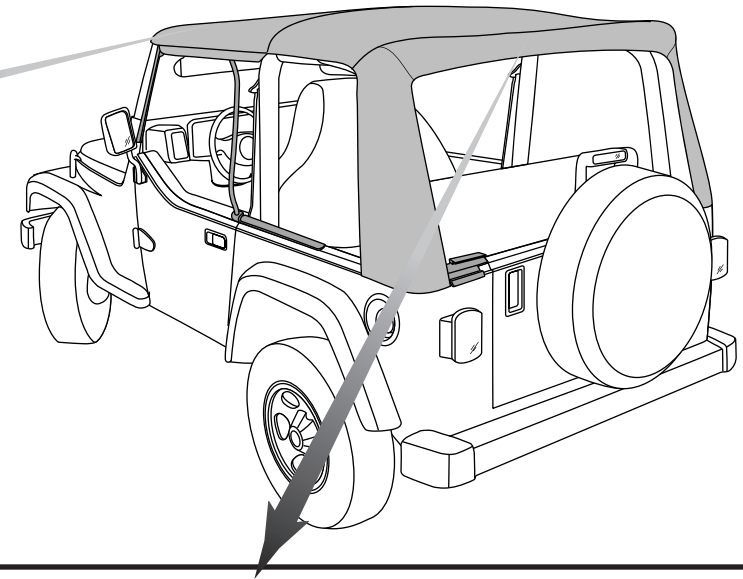

### Step Two

#### SNAP TOP TO REAR BOW

Fit the Rear Bow into the rear corners of the top. Snap the flaps to the six studs on the rear bow.

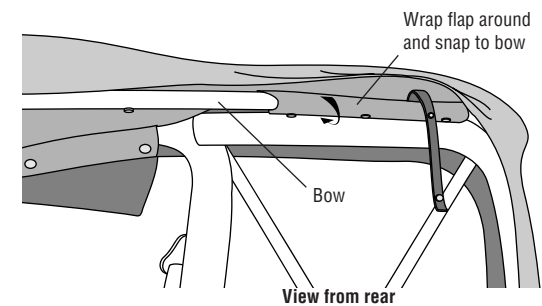

**Note:** If the snaps don't appear to line up, push the rear bow forward to relieve the pressure on the bow. This will allow the snaps to line up more easily.

### Step Three

#### SECURE REAR CORNER RETAINERS

Insert the plastic strips at rear corners of top into the corners of the belt rail retainer built into the top edge of the vehicle.

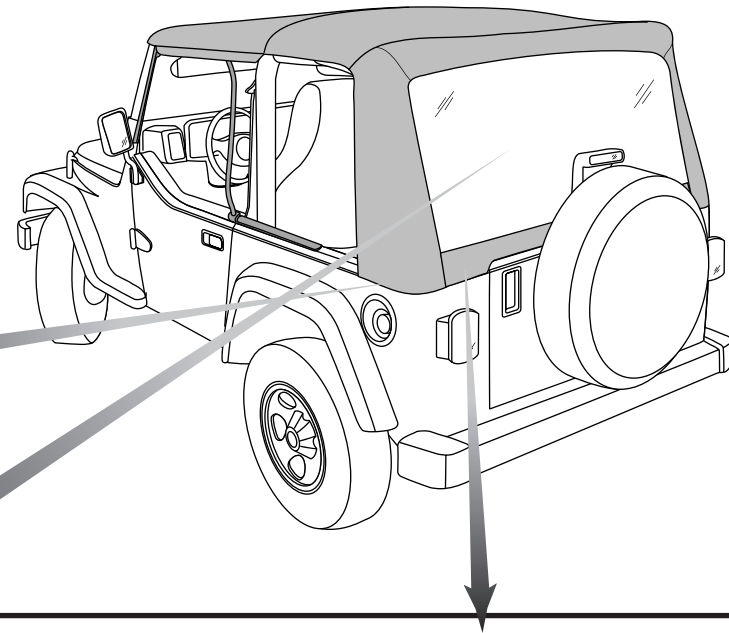
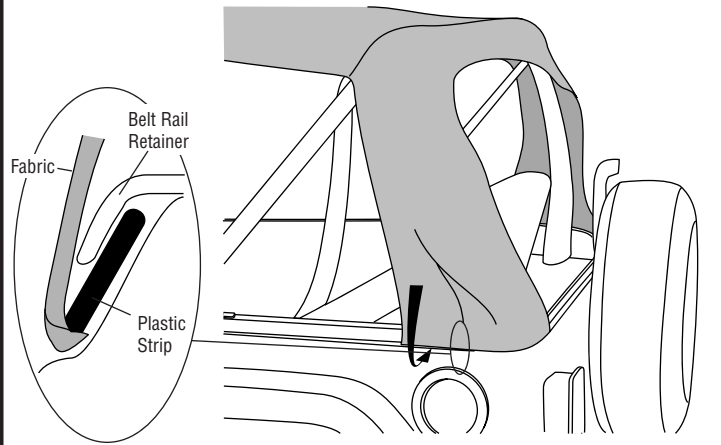

### Step Four

#### INSTALL REAR WINDOW

Locate the Rear Window in the parts kit. Orient it on the vehicle with the zippers toward the top. Catch the zipper on the driver's side, starting at the top corner and close the zipper a few inches. Then catch the top zipper, starting in the same corner and closing it a few inches. Finally, catch the zipper on the passenger side, starting at the top corner. Close all the zippers completely.

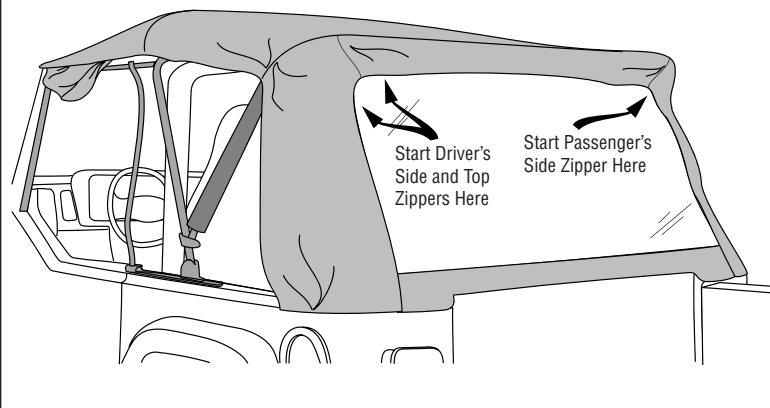

### Step Five

#### INSTALL TAILGATE BAR

Open the tailgate. Orient the Tailgate Bar from the old top with the rubber bulb facing down, in order to form a seal with the top of the tailgate. Slide the groove in the Tailgate Bar onto the tube inside the bottom of the Rear Window. Roll the Tailgate Bar into the top of the Tailgate Retainer Mounts. Slip the plastic on the bottom of the Rear Window under the bottom part of the Tailgate Retainer Mounts. Close the rear curtain zippers.

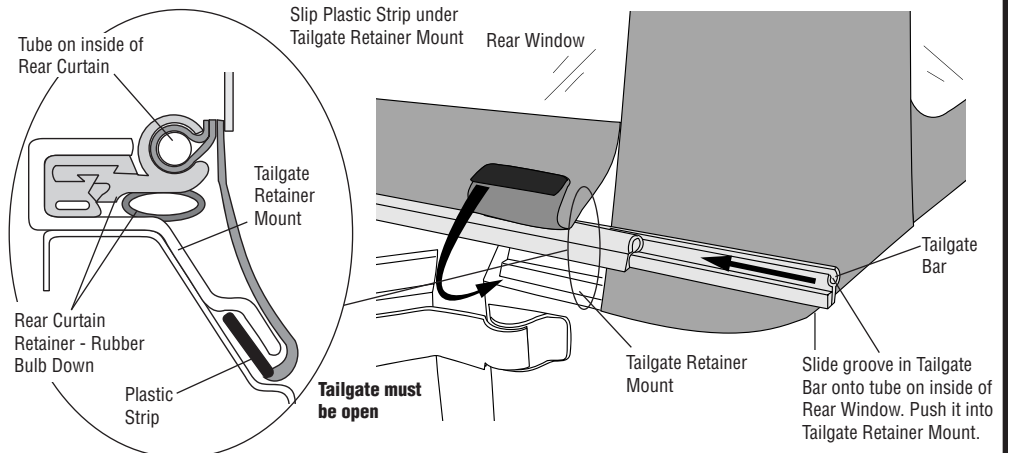

## Step Six

### INSTALL QUARTER WINDOWS

Locate the Left and Right Quarter Windows in the parts kit and orient them with the zippers toward the top and rear. Start the top zipper at the front corner and the rear zipper at the bottom rear corner. Close the zippers and tuck the top rear corner of the panel smoothly under the top.

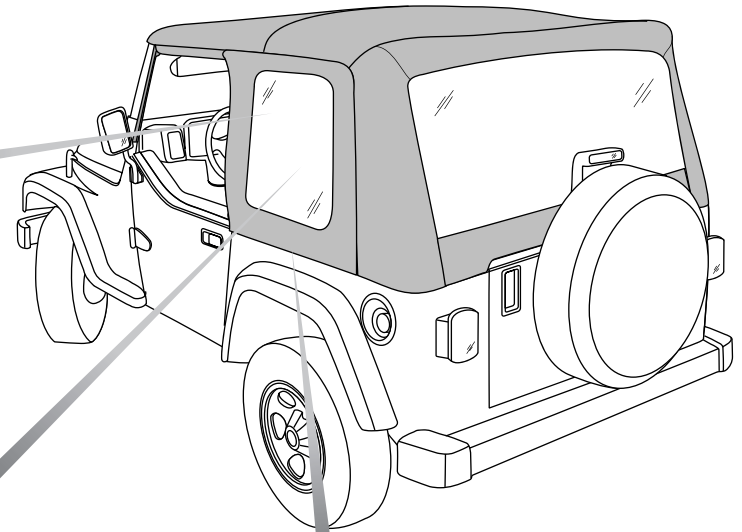
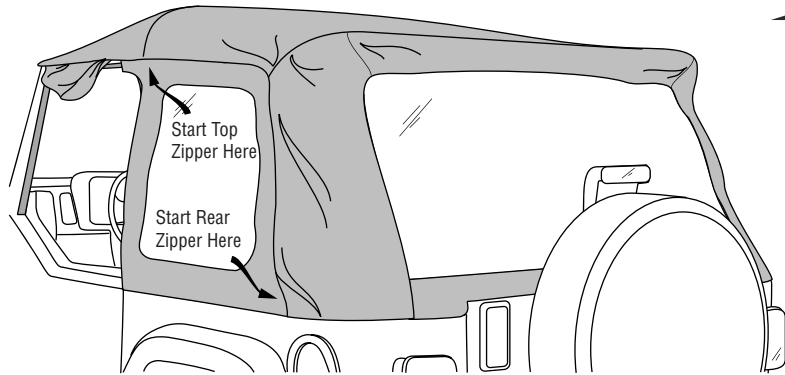

## Step Seven

### RAISE REAR BOW

Reach in under the Quarter Window and carefully slide the Rear Bow up on the Front Bow to increase the tension on the top. Be very careful not to scratch the windows. Insert the pin in the slide into the third hole (counting up from the bottom) of the four holes in the Front Bow.

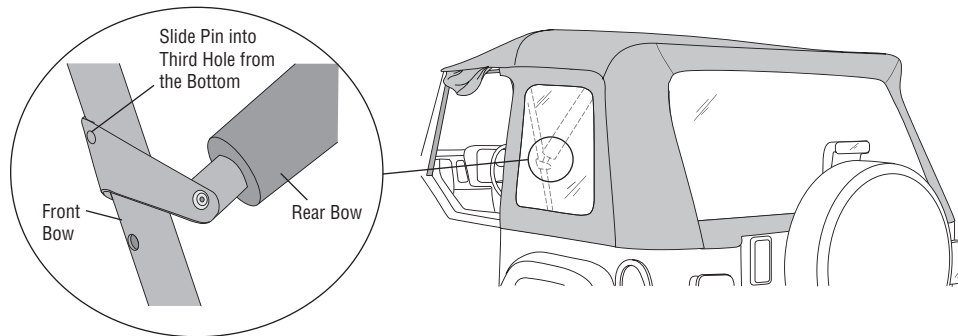

**Note:** If the top is extremely tight, slip the tab into a lower hole. The top will loosen up after a few hours in the sun. Then the pin may be inserted into a higher hole position.

## Step Eight

### SECURE PLASTIC STRIP ON QUARTER WINDOWS

Slip the plastic strip on the bottom of the Quarter Window into the belt rail built into the vehicle.

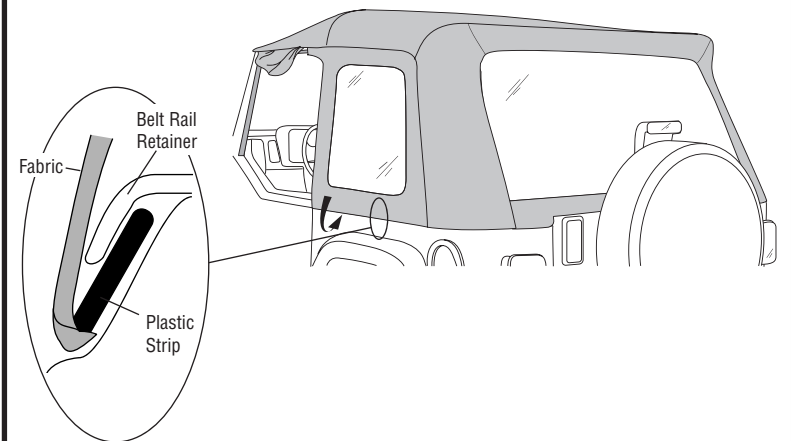

## Step Nine

### SECURE HOOK AND LOOP ON QUARTER WINDOWS

Fasten the hook and loop strips at the top front of the Quarter Window. Wrap fabric flap on the front of the Quarter Window around the Vertical Rod (not the front bow) and fasten the hook and loop strips to each other.

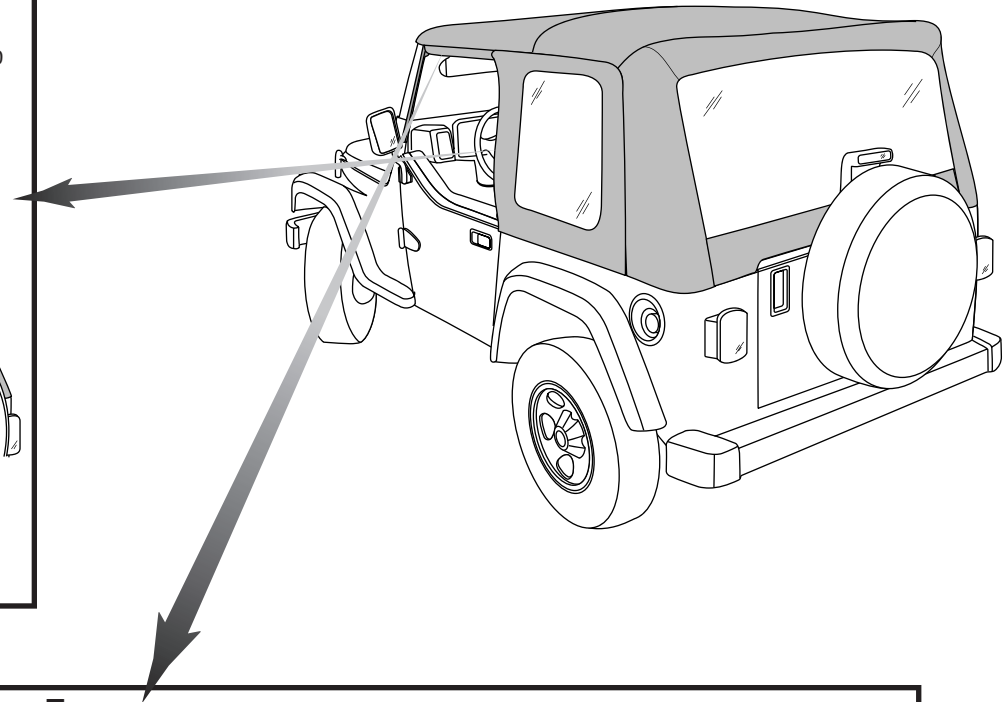
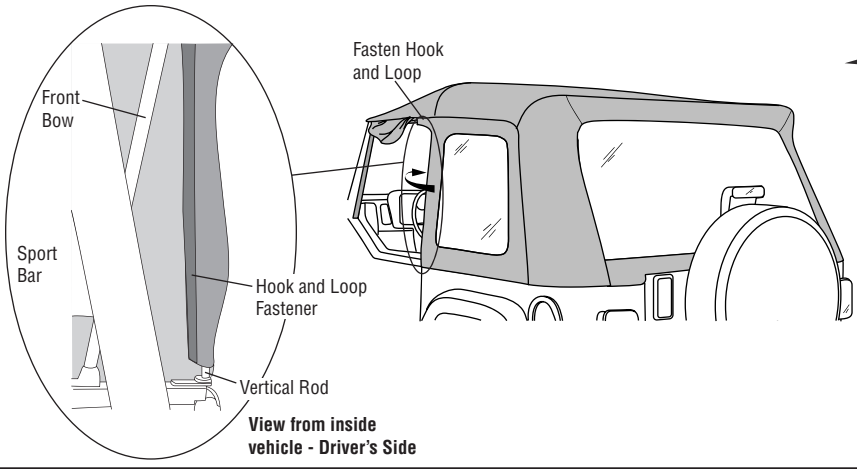

## Step Ten

### SECURE FLAPS ABOVE DOORS

Wrap the flap, sewn to the top above each door, around the Horizontal Rod and fasten the hook and loop strips to each other. Tuck the front edge of the flap, next to the windshield, up under the Bulb Seal.

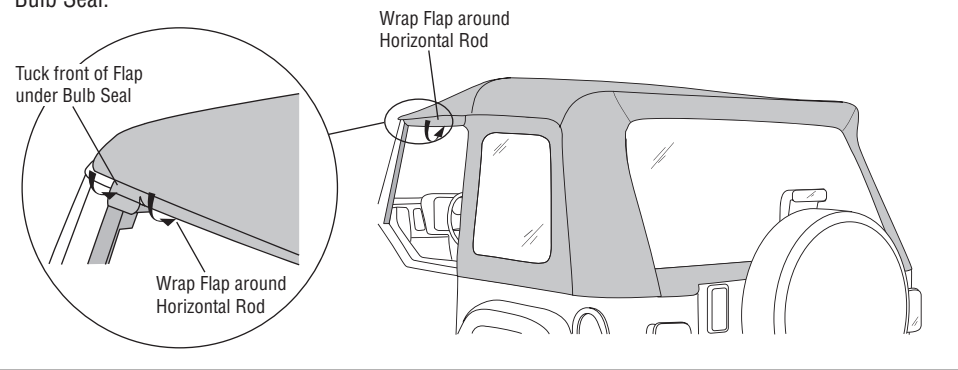



## WARNING

When operating the vehicle without the Quarter Windows, the Rear Curtain should be rolled up for proper ventilation.

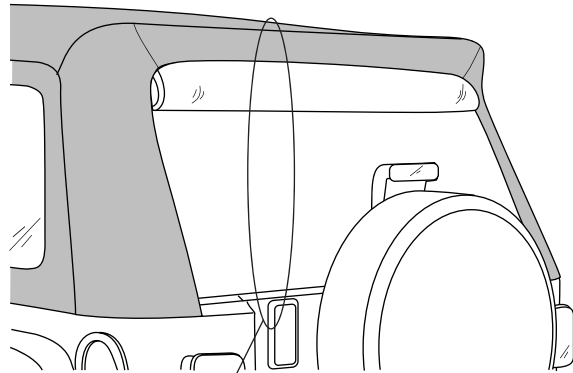

Detail of Rear Curtain

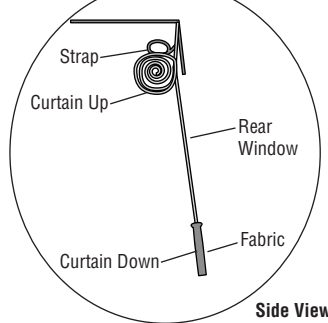

Side View

### Quarter Windows

To remove the Quarter Windows, unzip the rear and top zippers. Release the plastic strip from the retainer. Release the Hook and Loop Fasteners from around the Vertical Retainer.

### Rear Curtain

To roll up the Rear Curtain, remove the Tailgate Bar and start at the bottom, rolling it to the inside. Avoid wrinkles in the fabric and window. Secure it in place with the curtain straps inside of the top.

### Folding the Top Down

Open the zippers at the rear of the Quarter Windows. Pull the plastic strip on the bottom of the Quarter Windows out of the Belt Rails. Leave the rear corners of the top attached to the Belt Rails. Unfasten the hook and loop strips at the front of the Quarter Windows, releasing them from the Vertical Retainer. Fold the Quarter Windows up onto the top and release the hook and loop fasteners on the flaps, above the doors. Unsnap the top from the rear bow.

Release the locking pins on the Bow Slides from the holes in the bow and slide the rear bow down to the Bow Mounts. Release the Horizontal Rod from the A-Pillar. Remove the Vertical Rod from the Vertical Retainer Mount and lay the bow assembly down on the rear of the vehicle.

Pull the plastic strip along the front of the top out of the Windshield Retainer and lay it down on the body. Make sure that the rear corners of the top are tucked under the rear bow. Fold the top in half from front to back and continue folding until the top is about 1 foot wide at the rear of the vehicle. Secure the top by clipping the Bow Tie Downs into the Side Belt Rails.

### Removal of Soft Top for Open Air Driving

When operating the vehicle with the fabric top removed, it is very important that the supporting hardware system be disconnected from the A-Pillar molding and folded flat to the rear of the vehicle. The vertical and horizontal rods should be snapped into the plastic clips located on the inside of both bow mount brackets. Wrap the elastic straps around the bows and insert the plastic strip into the side belt rail. Never operate the vehicle with the fabric removed and the hardware in the fully erected position.

## Care and Maintenance of your New Top

Your top is made of the finest materials available. To keep it looking new and for the maximum possible wear, it will need periodic cleaning and maintenance.

**Washing:** The fabric should be washed often using soap, warm water and a soft bristle brush. Rinse with clear water to remove all traces of soap.

**Zippers:** Keeping the zipper cleaned and lubricated with a silicone lubricant will help prevent damage and keep the zippers in a smooth working condition. If a zipper opens behind the slider, the slider may have been spread apart. This problem can usually be repaired by using an ordinary pair of pliers to bring the sides back into parallel. Return slider to the end of the zipper in the normal Open position. Squeeze lightly at first and test the zipper. If the zipper continues to remain open squeeze more firmly with the pliers and try the zipper again. Repeat this procedure until the zipper operates correctly.

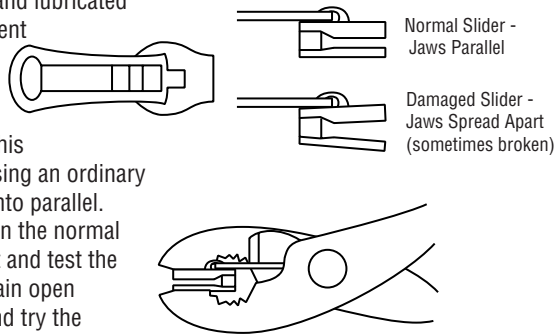

**Water:** In the event of seeping through the seams, 3M Scotchgard® may be applied on the inside of the seams to stop the seepage. Rips in the fabric may be repaired with Bondex® iron on patches. Iron the patches to the Inside of the top, carefully following the Bondex® instructions.

**Snaps:** Keep snaps cleaned and lubricated with silicone to help prevent snaps from sticking to the studs. If a snap does become stuck to a stud, use a screwdriver and GENTLY pry apart to prevent permanent damage to the snap or the top fabric.

## LIMITED WARRANTY

We warrant our product to be free from defects in material and workmanship, for terms specified below, provided there has been normal use and proper maintenance. This warranty applies to the original purchaser only. All remedies under this warranty are limited to the repair or replacement of any item or items found by the factory to be defective within the time period specified.

If you have a warranty claim, first you must call our factory at the number below for instructions. You must retain proof of purchase and submit a copy with any items returned for warranty work. Upon completion of warranty work, if any, we will return the repaired or replaced item or items to you freight prepaid. Damage to our products caused by accidents, fire, vandalism, negligence, misinstallation, misuse, Acts of God, or by defective parts not manufactured by us, is not covered under this warranty.

THE WARRANTY TIME PERIOD IS AS FOLLOWS: ALL "SOFT GOODS" MANUFACTURED BY OUR COMPANY (USING PRIMARILY VINYL, PLASTICS, AND/OR FOAM): ONE YEAR FROM DATE OF PURCHASE.

ANY IMPLIED WARRANTIES OF MERCHANTABILITY AND/OR FITNESS FOR A PARTICULAR PURPOSE CREATED HEREBY ARE LIMITED IN DURATION TO THE SAME DURATION AND SCOPE AS THE EXPRESS WRITTEN WARRANTY. OUR COMPANY SHALL NOT BE LIABLE FOR ANY INCIDENTAL OR CONSEQUENTIAL DAMAGE.

Some states do not allow limitations on how long an implied warranty lasts, or the exclusion or limitation of incidental or consequential damages, so the above limitations or exclusions may not apply to you.

This warranty gives you specific legal rights, and you may also have other rights which vary from state to state.

For further information, please contact: Bestop Inc.  
Customer Service  
(800)845-3567  
(303)465-1755