

YEARS: 2012-PRESENT

MAKE: FIAT

MODEL: 500

STYLE: HATCHBACK

WARNING: NEVER EXCEED YOUR VEHICLE MANUFACTURER'S RECOMMENDED TOWING CAPACITY

WEIGHT CARRYING:
 TRAILER WEIGHT: 2000 LBS.
 TONGUE WEIGHT: 200 LBS.

WARNING:
 WE RECOMMEND THE USE OF 18050 STABILIZING STRAPS FOR ALL NON-TRAILER (WHEEL-LESS) LOADS. PLEASE SEE THE CURT CATALOG OR VISIT US ONLINE AT WWW.CURTMFG.COM FOR FURTHER INFORMATION.

INSTALLATION TIME: 40 MIN.

THE INSTALL TIME LISTED IS FOR PROFESSIONAL INSTALLERS. IF YOU ARE HESITANT TO UNDERTAKE THIS TASK ON YOUR OWN, CONTACT AN AUTHORIZED CURT INSTALLER FOR ADDITIONAL ASSISTANCE.

INSTALLATION TIPS:

- BEFORE YOU BEGIN INSTALLATION, READ ALL INSTRUCTIONS THOROUGHLY.
- TO EASE INSTALLATION, 2 PEOPLE MAY BE REQUIRED.
- USING PROPER TOOLS WILL GREATLY IMPROVE THE QUALITY OF THE INSTALL AND REDUCE THE TIME REQUIRED.
- NEED HELP OR HAVE SOME QUESTIONS? CALL TECHNICAL SUPPORT AT 800.798.0813



INSTALLATION REQUIRES:

DRILL BIT 7/16"	POWER DRILL	11mm 13mm 11/16" SOCKET
RATCHET	TORQUE WRENCH	SAFETY GLASSES
PRY BAR		

LEVEL OF DIFFICULTY: MODERATE

EASY	MODERATE	CHALLENGING
	LOWER EXHAUST	
PART REMOVAL	REMOVE/REINSTALL HEAT SHIELD	
	MAY REQUIRE WELDNUT CLEANING	
	ENLARGE HOLE FOR HARDWARE	
TRIM	TRIM HEAT SHIELD	

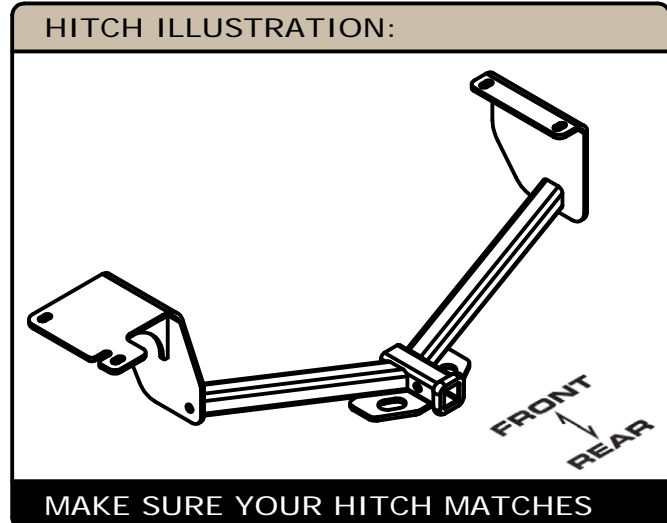

PERIODICALLY CHECK THIS RECEIVER HITCH TO ENSURE ALL FASTENERS ARE TIGHT AND ALL STRUCTURAL COMPONENTS ARE SOUND

CURT Manufacturing LLC. warrants this product to be free of defects in material and/or workmanship at the time of retail purchase by the original purchaser. If the product is found to be defective, Curt Manufacturing LLC. may repair or replace the product at their option, when the product is returned, prepaid, with proof of purchase. Alteration to, misuse of, or improper installation of this product voids the warranty. Curt Manufacturing LLC.'s liability is limited to repair or replacement of products found to be defective, and specifically excludes liability for incidental or consequential loss or damage.

For more information log onto www.curtmfg.com, & for helpful towing tips log onto www.hitchinfo.com

INSTALLATION WALKTHROUGH:

Parts List			
ITEM	QTY	PART NUMBER	DESCRIPTION
1	2	M8 - 1.25 x 30	HEX HEAD BOLT
2	2	3/8"	TOOTHED WASHER
3	2	7/16 FISHWIRE	7/16" FISHWIRE
4	2	7/16-14	HEX FLANGE NUT
5	2	7/16-14 x 1 1/4	CARRIAGE BOLT
6	2	CM-SP2	SPACER

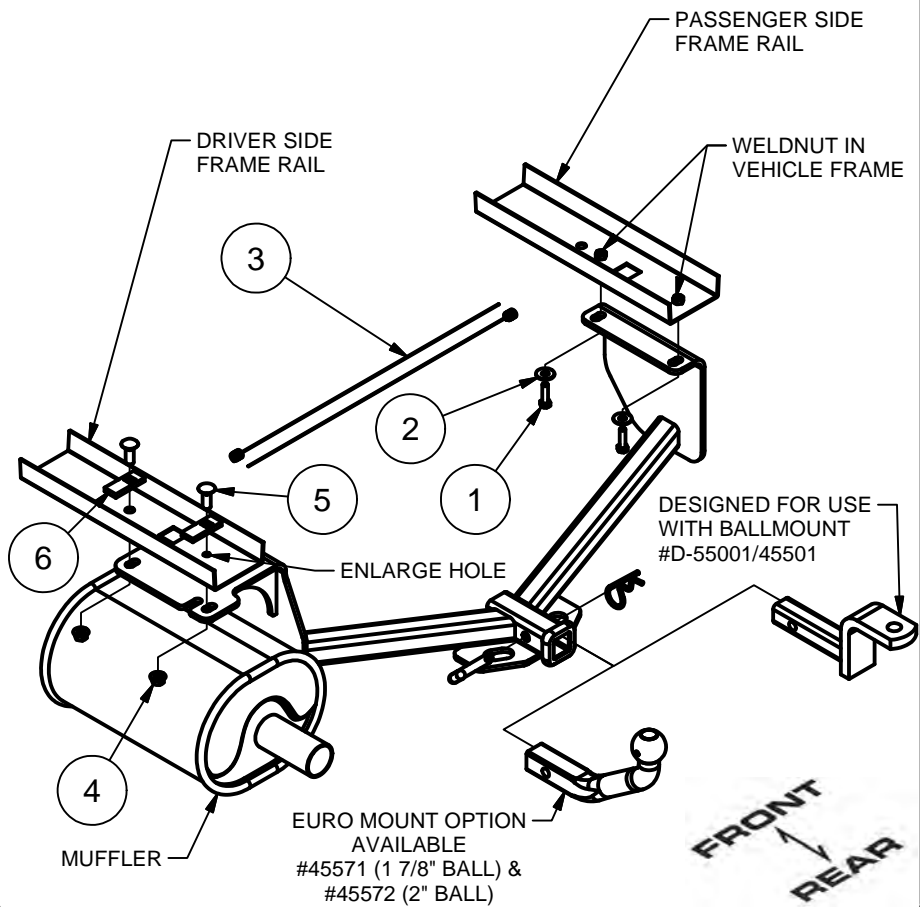

1. Lower exhaust by removing rubber exhaust hanger from hanger rod, two (2) places. Remove heat shield by removing four (4) hex nuts.
Note: Heat shield will be modified and reinstalled using two (2) hex nuts.

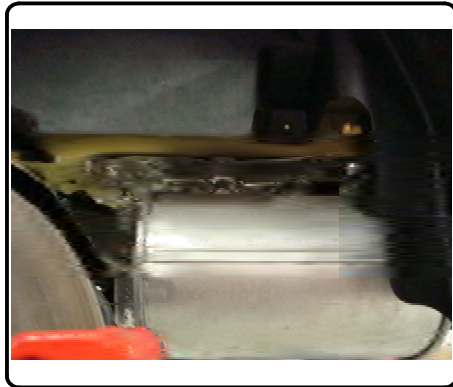

2. If vehicle is equipped with a spare tire, remove two (2) bolts which attach spare tire control box to passenger side frame rail.
Note: If vehicle does not have spare tire option, weldnuts can be found by removing protective tape from frame rail. Remove square plug from frame rails to reveal square access holes in frame. Return plugs to vehicle owner.



INSTALLATION WALKTHROUGH:

3. Using a 7/16" drill bit, enlarge hole at end of driver side frame rail. On driver side, fishwire 7/16" carriage bolts and spacer blocks up through square hole and down through mounting holes as shown.



4. Raise hitch into position, taking care not to push carriage bolts back into frame and sandwiching hitch passenger side plate between frame rail and spare tire control box, if equipped. Install M8 hex bolts and 7/16" conical toothed washers into weldnuts in passenger side frame rail. Install flanged hex nuts onto carriage bolts in driver side frame rail. Torque all 7/16" fasteners to 50 lb.-ft.; Torque all M8 fasteners to 18 lb.-ft.

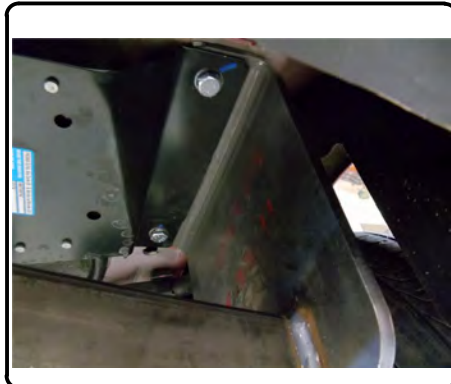

5. Trim heat shield as shown and install heat shield using two (2) hex nuts removed in step 1 and discard the other two (2) hex nuts. Raise exhaust back into position by reattaching rubber exhaust hangers to hanger rods.



Install is complete.



11168**FIAT 500 - ALL MODELS**

5/10/2011

GROSS LOAD CAPACITY WHEN USED AS A WEIGHT CARRYING HITCH: 2,000 LBS. TRAILER WEIGHT & 200 LBS. TONGUE WEIGHT.*****DO NOT EXCEED VEHICLE MANUFACTURER'S RECOMMENDED TOWING CAPACITY.*******WARNING: ALL NON-TRAILER LOADS APPLIED TO THIS PRODUCT MUST BE SUPPORTED BY 18050 STABILIZING STRAPS.****** FAILURE TO PROPERLY SUPPORT NON-TRAILER LOADS WILL VOID PRODUCT WARRANTY******HAVING INSTALLATION QUESTIONS? CALL TECHNICAL SUPPORT AT 1-800-798-0813**

		Parts List	
ITEM	QTY	PART NUMBER	DESCRIPTION
1	2	M8 - 1.25 x 30	HEX HEAD BOLT
2	2	3/8"	CONICAL TOOTHED WASHER
3	2	7_16 FISHWIRE	7/16" FISHWIRE
4	2	7/16-14	HEX FLANGE NUT
5	2	7/16-14 x 1 1/4	CARRIAGE BOLT
6	2	CM-SP2	.250 x .88 x 2.25" SQUARE HOLE SPACER

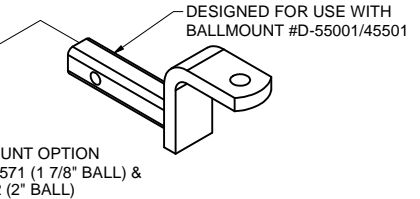
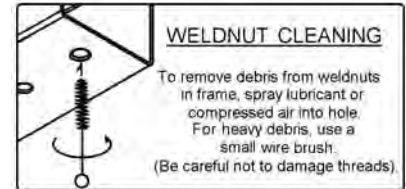
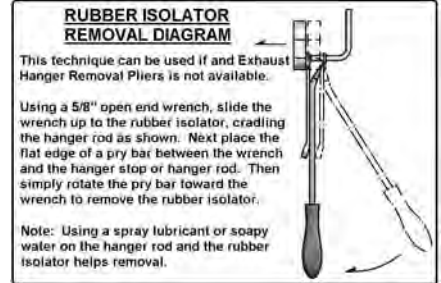
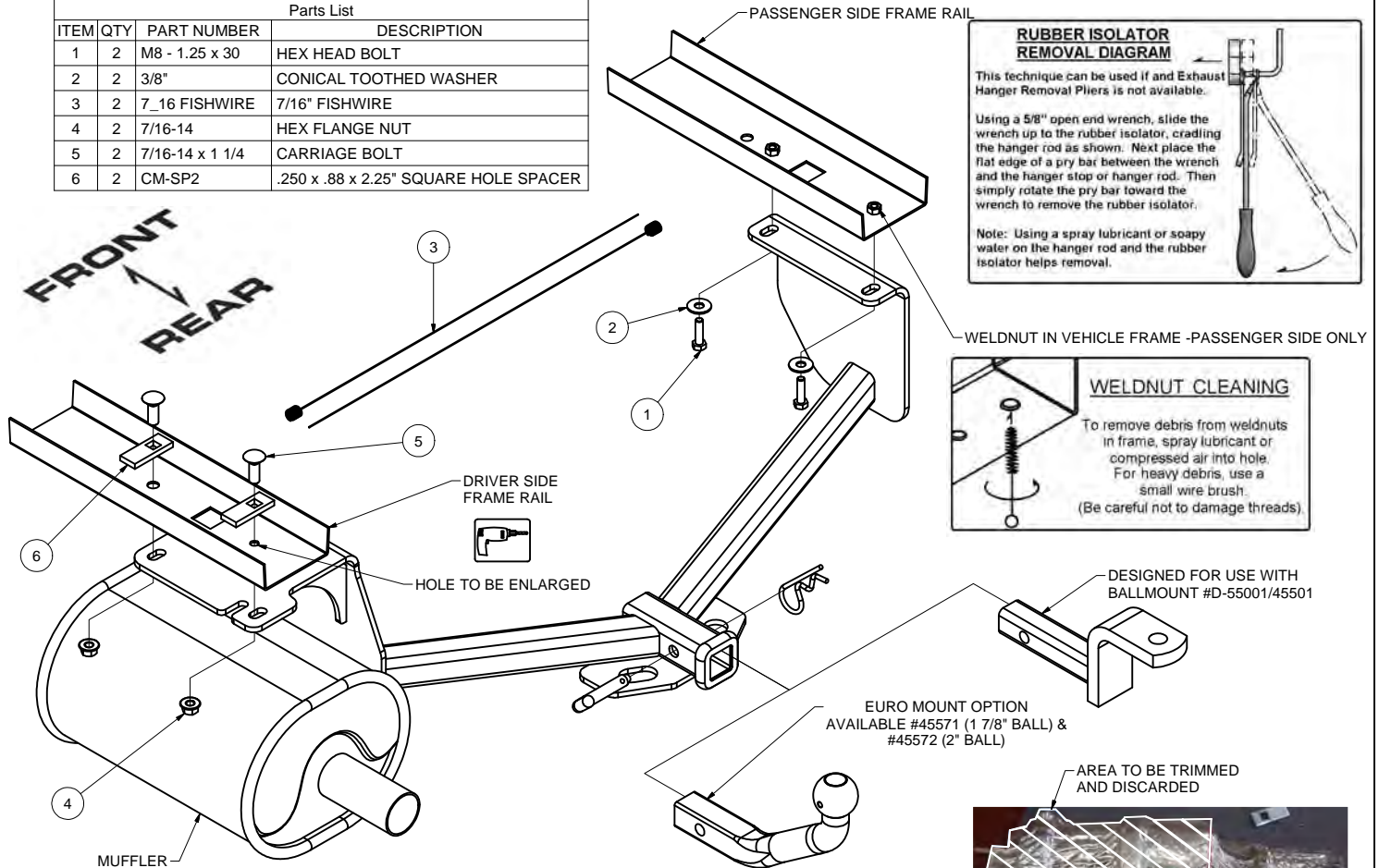

HITCH WEIGHT: 29 LBS.

INSTALL TIME

PROFESSIONAL: 40 MINUTES

NOVICE (DIY): 80 MINUTES

INSTALL NOTES:

- LOWER EXHAUST
- HOLE ENLARGEMENT REQUIRED
- FISHWIRE HARDWARE
- TRIM HEAT SHIELD

TOOLS REQUIRED

- RATCHET
- PRY BAR
- 11mm SOCKET
- 13mm SOCKET
- 11/16" SOCKET
- TORQUE WRENCH
- 7/16" DRILL BIT
- POWER DRILL

INSTALLATION STEPS

- Lower exhaust by removing rubber exhaust hanger from hanger rod, two places. Remove heat shield by removing four (4) hex nuts.
Note: Heat shield will be modified and reinstalled using two (2) hex nuts.
- If vehicle is equipped with a spare tire, remove two bolts which attach spare tire control box to passenger side frame rail. Remove square rubber plug from frame rails to reveal square holes in frame. Return plugs to vehicle owner.
Note: If vehicle does not have spare tire option, weldnuts can be found by removing protective tape from frame rail.
- Using a 7/16" drill bit, enlarge hole at end of driver side frame rail. On driver side, fishwire 7/16" carriage bolts and spacer blocks up through square hole and down through mounting holes as shown.
- Raise hitch into position, taking care not to push carriage bolts back into frame and sandwiching hitch passenger side plate between frame rail and spare tire control box, if equipped. Install M8 hex bolts and 7/16" conical toothed washers into weldnuts in passenger side frame rail. Install flanged hex nuts onto carriage bolts in driver side frame rail. Torque all 7/16" fasteners to 50 lb.-ft.; Torque all M8 fasteners to 18 lb.-ft.
- Trim heat shield as shown in trim diagram and install heat shield using two (2) hex nuts removed in Step 2 and discard the other two (2) hex nuts. Raise exhaust back into position by reattaching rubber exhaust hangers to hanger rods.

PERIODICALLY CHECK THIS RECEIVER HITCH TO ENSURE THAT ALL FASTENERS ARE TIGHT AND THAT ALL STRUCTURAL COMPONENTS ARE SOUND.

Curt Manufacturing LLC., warrants this product to be free of defects in material and/or workmanship at the time of retail purchase by the original purchaser. If the product is found to be defective, Curt Manufacturing LLC., may repair or replace the product, at their option, when the product is returned, prepaid, with proof of purchase. Alteration to, misuse of, or improper installation of this product voids the warranty. Curt Manufacturing LLC.'s liability is limited to repair or replacement of products found to be defective, and specifically excludes liability for incidental or consequential loss or damage.