



13059 INSTALLATION INSTRUCTIONS



Safety glasses should be worn at all times while installing this product.

YEARS: 2010-2012

MAKE: MERCEDES BENZ

MODEL: GLK350 4MATIC

STYLE: SUV

WARNING: NEVER EXCEED YOUR VEHICLE MANUFACTURER'S RECOMMENDED TOWING CAPACITY

WEIGHT CARRYING:
TRAILER WEIGHT: 3,500 LBS.
TONGUE WEIGHT: 350 LBS.

WARNING:
WE RECOMMEND THE USE OF 18050 STABILIZING STRAPS FOR ALL NON-TRAILER (WHEEL-LESS) LOADS. PLEASE SEE THE CURT CATALOG OR VISIT US ONLINE AT WWW.CURTMFG.COM FOR FURTHER INFORMATION.

INSTALLATION TIME: 60 MIN.

THE INSTALL TIME LISTED IS FOR PROFESSIONAL INSTALLERS. IF YOU ARE HESITANT TO UNDERTAKE THIS TASK ON YOUR OWN, CONTACT AN AUTHORIZED CURT INSTALLER FOR ADDITIONAL ASSISTANCE.



INSTALLATION TIPS:

1. BEFORE YOU BEGIN INSTALLATION, READ ALL INSTRUCTIONS THOROUGHLY.
2. TO EASE INSTALLATION, 2 PEOPLE MAY BE REQUIRED.
3. USING PROPER TOOLS WILL GREATLY IMPROVE THE QUALITY OF THE INSTALL AND REDUCE THE TIME REQUIRED.
4. NEED HELP OR HAVE SOME QUESTIONS? CALL TECHNICAL SUPPORT AT 800.798.0813

INSTALLATION REQUIRES:

 RATCHET	 TORQUE WRENCH	 POWER DRILL
 DIE GRINDER	 DRILL BIT 1/2"	 3/4" 11/16" 10mm SOCKET
 4" SOCKET EXTENSION		

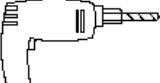
LEVEL OF DIFFICULTY: MODERATE

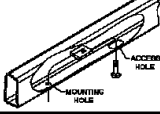
EASY	MODERATE	HARD
	- ENLARGE HOLES	
	- LOWER EXHAUST	
	- FISHWIRE HARDWARE	

VEHICLE PHOTO:



REPRESENTATIVE PHOTO

HITCH ILLUSTRATION:

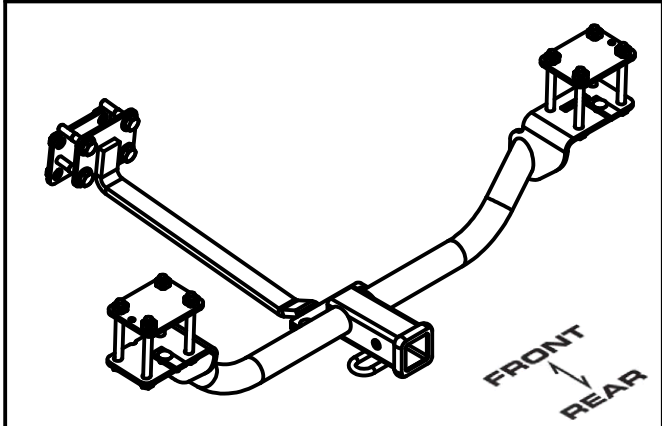

MAKE SURE YOUR HITCH MATCHES

PERIODICALLY CHECK THIS RECEIVER HITCH TO ENSURE ALL FASTENERS ARE TIGHT AND ALL STRUCTURAL COMPONENTS ARE SOUND

CURT Manufacturing Inc. warrants this product to be free of defects in material and/or workmanship at the time of retail purchase by the original purchaser. If the product is found to be defective, Curt Manufacturing Inc. may repair or replace the product at their option, when the product is returned, prepaid, with proof of purchase. Alteration to, misuse of, or improper installation of this product voids the warranty. Curt Manufacturing Inc.'s liability is limited to repair or replacement of products found to be defective, and specifically excludes liability for incidental or consequential loss or damage.

For more information log onto www.curtmfg.com, & for helpful towing tips log onto www.hitchinfo.com

INSTALLATION WALKTHROUGH:

Parts List			
ITEM	QTY	PART NUMBER	DESCRIPTION
1	8	1_2 - 13 x 5 HEX	HEX BOLT
2	4	7/16-14	HEX FLANGE NUT
3	4	1/2 - 13 x 2 1/2	HEX BOLT
4	12	1/2"	CONICAL TOOTHED WASHER
5	2	7_16 FISHWIRE	7/16" FISHWIRE
6	2	7/16-14 x 1	CARRIAGE BOLT
7	2	7/16-14 x 1 1/4	CARRIAGE BOLT
8	2	CM-SP2	.250 x .88 x 2.25" SQUARE HOLE SPACER

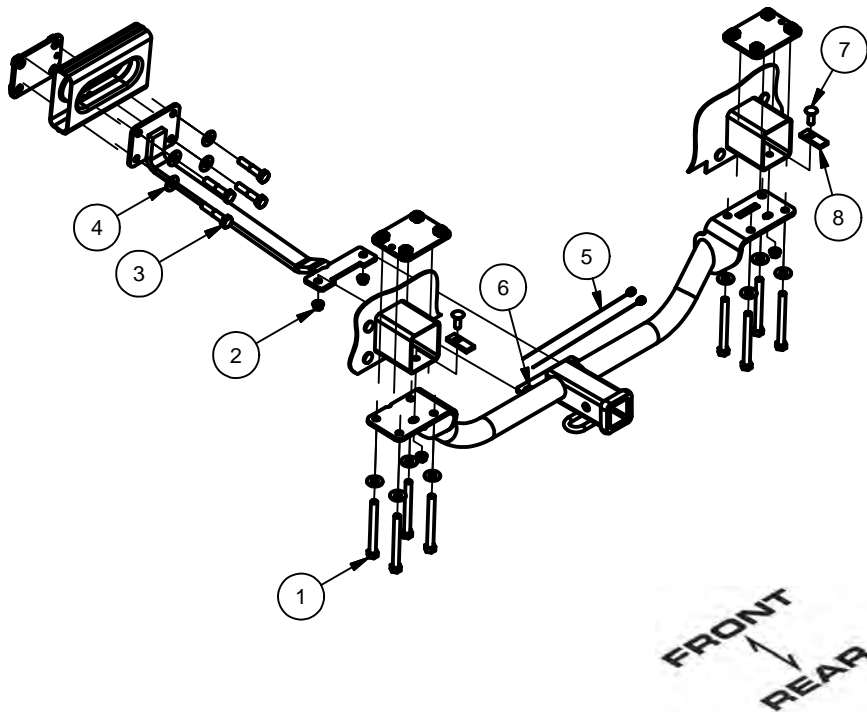

1. Lower exhaust by removing (2) isolators on the driver side muffler, (2) isolators on the passenger side muffler, and (2) isolators forward of the mufflers. Support as needed to prevent damage.

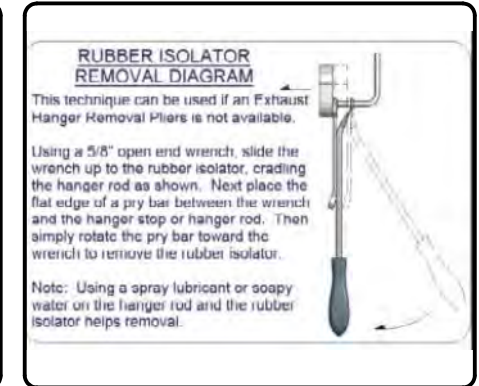

2. Remove (2) screws securing rear fascia to underbody panel. Save screws for re-installation in Step (18).



INSTALLATION WALKTHROUGH:

3. Enlarge existing slot in the bottom of the driver and the passenger side bumper beams large enough to allow the threaded portion of a 7/16" carriage bolt to pass through.



4. Locate channel behind driver side bumper fascia leading to access hole in driver side bumper beam. Fishwire 7/16-14 x 1 1/4" carriage bolt and SP2 spacer through access hole and out enlarged hole in driver side bumper beam.

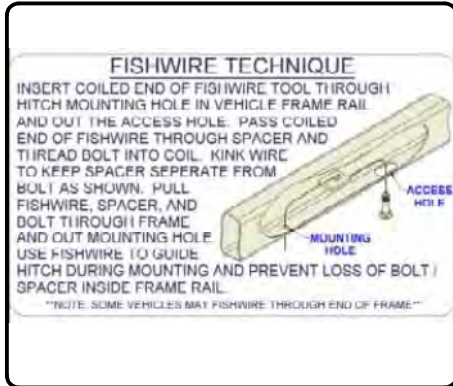

5. Locate square access cover on the outside of the bumper fascia on the passenger side of vehicle. Push in on side of cover with the arrow to open. Fishwire 7/16-14 x 1 1/4" carriage bolt and SP2 spacer through fascia access hole and out enlarged hole in passenger side bumper beam. Replace access cover when finished.



6. Place supplied nut plates over bumper beam. Raise hitch into position over exhaust and loosely secure hitch into place with 7/16" flange nuts. **Note:** Be sure to slide hitch as far forward as possible but not so it rests on the weld seam on the vehicle bumper beams.



INSTALLATION WALKTHROUGH:

7. Loosely secure hitch to nut plates with 1/2-13 x 5" hex bolts and 1/2" conical toothed washers.



8. Insert 7/16-14 x 1" carriage bolts through top of square holes behind receiver tube of hitch. Raise mounting strap between vehicle crossmember. Loosely secure mounting strap to hitch with 7/16" flange nuts.



9. Raise nut plate in front of vehicle crossmember. Loosely secure nut plate to mounting strap with 1/2-13 x 2 1/2" hex bolts and 1/2" conical toothed washers.

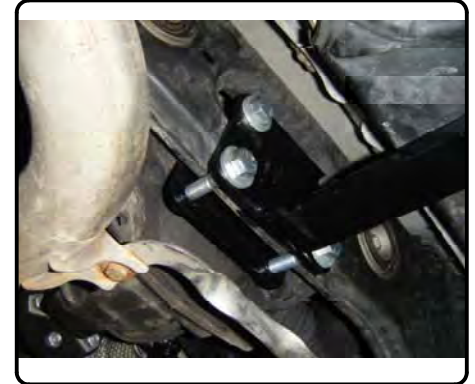

10. Torque all 1/2" hardware to 110 ft-lbs and all 7/16" hardware to 70 ft-lbs. Reinstall (2) screws removed in Step (2). Raise exhaust back into position. Hitch installation is complete.

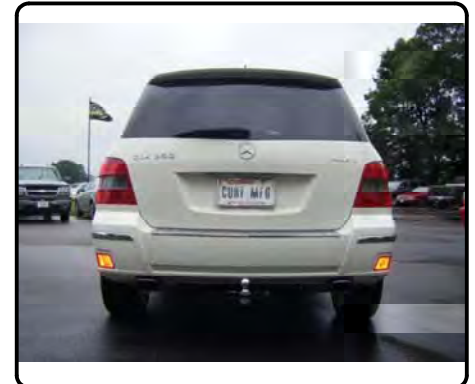

13059

MERCEDES BENZ GLK350 4MATIC

9/26/2011

PAGE 1 OF 3

GROSS LOAD CAPACITY WHEN USED AS A WEIGHT CARRYING HITCH: 3,500 LBS. TRAILER WEIGHT & 350 LBS. TONGUE WEIGHT.

DO NOT EXCEED VEHICLE MANUFACTURER'S RECOMMENDED TOWING CAPACITY.

WARNING: ALL NON-TRAILER LOADS APPLIED TO THIS PRODUCT MUST BE SUPPORTED BY AUXILIARY STABILIZING STRAPS.

** FAILURE TO PROPERLY SUPPORT NON-TRAILER LOADS WILL VOID PRODUCT WARRANTY**

HAVING INSTALLATION QUESTIONS? CALL TECHNICAL SUPPORT AT 1-800-798-0813

Parts List			
ITEM	QTY	PART NUMBER	DESCRIPTION
1	2	7_16 FISHWIRE	7/16" FISHWIRE
2	2	7/16-14 x 1 1/4	CARRIAGE BOLT
3	2	CM-SP2	.250 x .88 x 2.25" SQUARE HOLE SPACER
4	12	1/2"	CONICAL TOOTHED WASHER
5	4	7/16-14	HEX FLANGE NUT
6	8	1_2 - 13 x 5 HEX	HEX BOLT
7	2	7/16-14 x 1	CARRIAGE BOLT
8	4	1/2 - 13 x 2 1/2	HEX BOLT
9	3	CM-NP1W	NUT PLATE WELDMENT

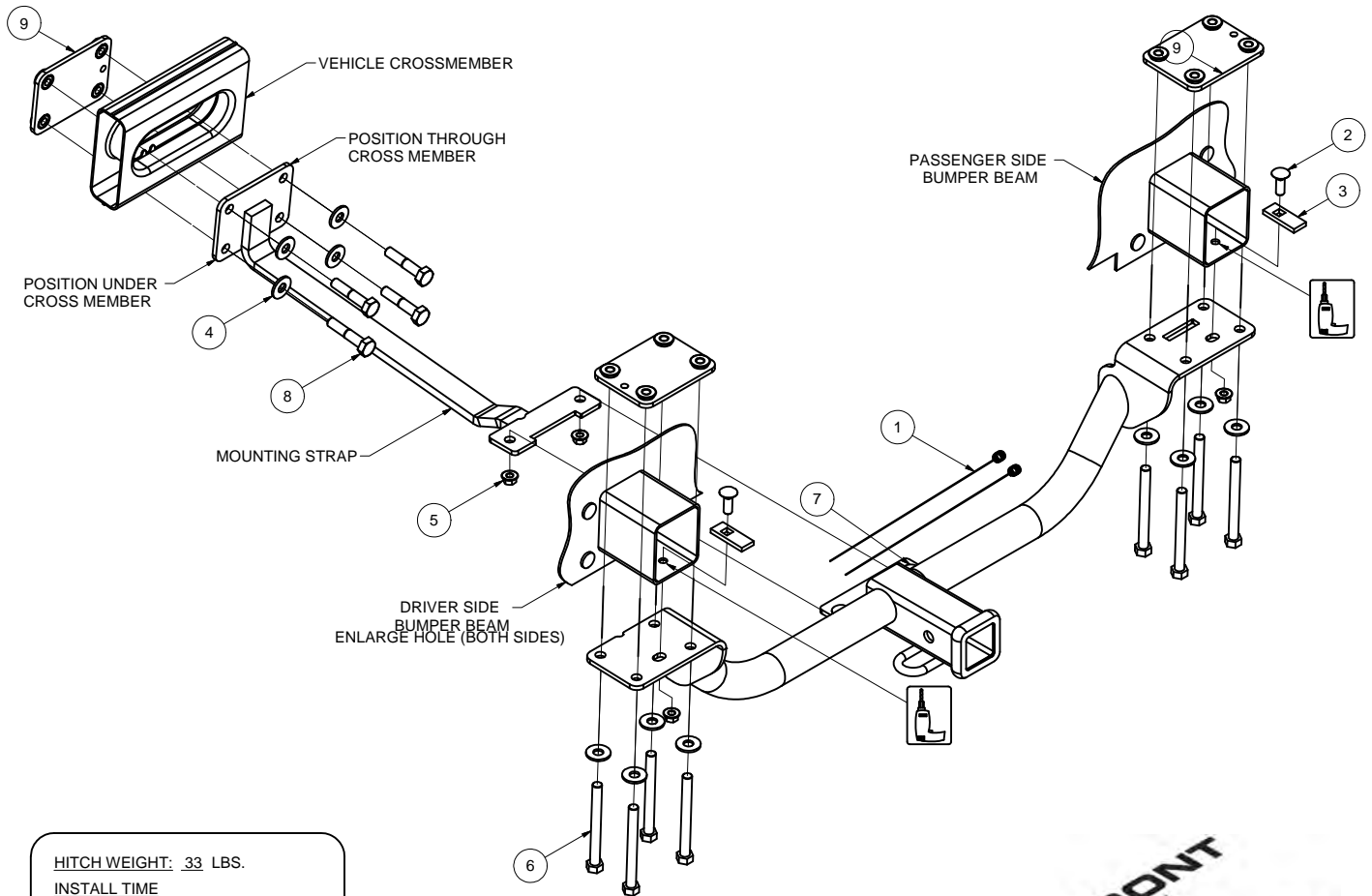

HITCH WEIGHT: 33 LBS.

INSTALL TIME

PROFESSIONAL: 60 MINUTES

NOVICE (DIY): 120 MINUTES

INSTALL NOTES:

- ENLARGE HOLES
- LOWER EXHAUST
- FISHWIRE HARDWARE

PERIODICALLY CHECK THIS RECEIVER HITCH TO ENSURE THAT ALL FASTENERS ARE TIGHT AND THAT ALL STRUCTURAL COMPONENTS ARE SOUND.

Curt Manufacturing Inc., warrants this product to be free of defects in material and/or workmanship at the time of retail purchase by the original purchaser. If the product is found to be defective, Curt Manufacturing Inc., may repair or replace the product, at their option, when the product is returned, prepaid, with proof of purchase. Alteration to, misuse of, or improper installation of this product voids the warranty. Curt Manufacturing Inc.'s liability is limited to repair or replacement of products found to be defective, and specifically excludes liability for incidental or consequential loss or damage.

GROSS LOAD CAPACITY WHEN USED AS A WEIGHT CARRYING HITCH: 3,500 LBS. TRAILER WEIGHT & 350 LBS. TONGUE WEIGHT.

DO NOT EXCEED VEHICLE MANUFACTURER'S RECOMMENDED TOWING CAPACITY.

WARNING: ALL NON-TRAILER LOADS APPLIED TO THIS PRODUCT MUST BE SUPPORTED BY AUXILIARY STABILIZING STRAPS.

** FAILURE TO PROPERLY SUPPORT NON-TRAILER LOADS WILL VOID PRODUCT WARRANTY**

HAVING INSTALLATION QUESTIONS? CALL TECHNICAL SUPPORT AT 1-800-798-0813

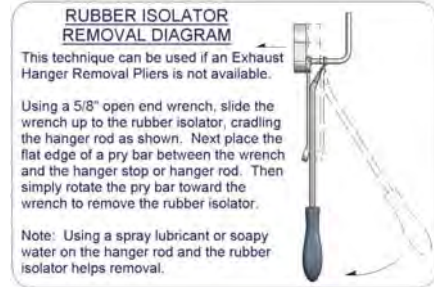
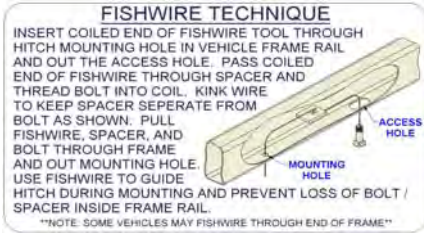

TOOLS REQUIRED
DRILL
1/2" DRILL BIT
DIE GRINDER
SOCKET WRENCH
10mm SOCKET
11/16" SOCKET
3/4" SOCKET
4" SOCKET EXTENSION
TORQUE WRENCH

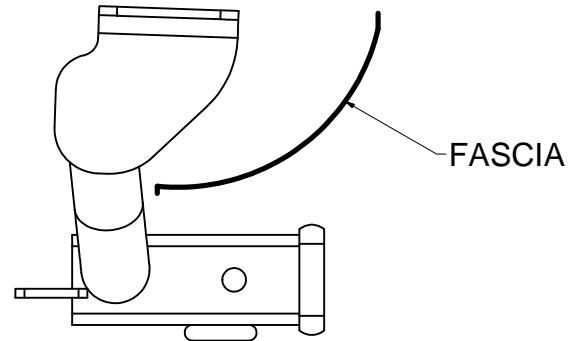

INSTALLED HITCH POSITION



PASSENGER SIDE FISHWIRE LOCATION

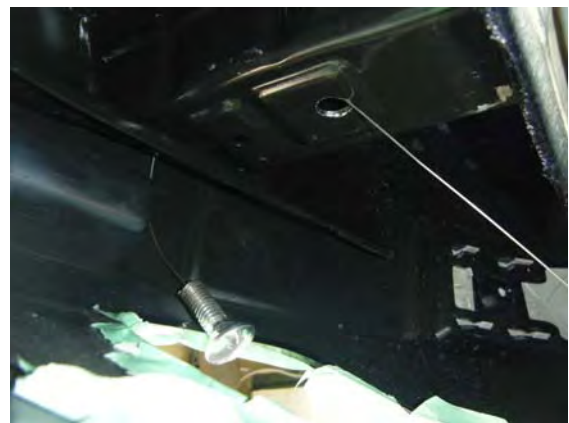

DRIVER SIDE FISHWIRE LOCATION

PERIODICALLY CHECK THIS RECEIVER HITCH TO ENSURE THAT ALL FASTENERS ARE TIGHT AND THAT ALL STRUCTURAL COMPONENTS ARE SOUND.

Curt Manufacturing Inc., warrants this product to be free of defects in material and/or workmanship at the time of retail purchase by the original purchaser. If the product is found to be defective, Curt Manufacturing Inc., may repair or replace the product, at their option, when the product is returned, prepaid, with proof of purchase. Alteration to, misuse of, or improper installation of this product voids the warranty. Curt Manufacturing Inc.'s liability is limited to repair or replacement of products found to be defective, and specifically excludes liability for incidental or consequential loss or damage.

GROSS LOAD CAPACITY WHEN USED AS A WEIGHT CARRYING HITCH: 3,500 LBS. TRAILER WEIGHT & 350 LBS. TONGUE WEIGHT.

DO NOT EXCEED VEHICLE MANUFACTURER'S RECOMMENDED TOWING CAPACITY.

WARNING: ALL NON-TRAILER LOADS APPLIED TO THIS PRODUCT MUST BE SUPPORTED BY AUXILIARY STABILIZING STRAPS.

** FAILURE TO PROPERLY SUPPORT NON-TRAILER LOADS WILL VOID PRODUCT WARRANTY**

HAVING INSTALLATION QUESTIONS? CALL TECHNICAL SUPPORT AT 1-800-798-0813

INSTALLATION STEPS

1. Lower exhaust by removing (2) isolators on the driver side muffler, (2) isolators on the passenger side muffler, and (2) isolators forward of the mufflers. (See RUBBER ISOLATOR REMOVAL DIAGRAM.)
2. Tie up exhaust with wire high enough to avoid damaging the exhaust tubes.
3. Remove (2) screws securing rear fascia to underbody panel. Save screws for re-installation in Step 20.
4. Enlarge existing slot in bottom of driver and passenger side bumper beams large enough to allow the threaded portion of a 7/16" carriage bolt to pass through.
5. Locate channel behind driver side bumper fascia leading to access hole in driver side bumper beam. (See Page 2 for diagram showing location of channel.)
6. Fishwire 7/16" x 1 1/4" carriage bolt and CM-SP2 spacer through access hole located in Step 5 and out enlarged hole in driver side bumper beam. (See FISHWIRE TECHNIQUE diagram.)
7. Locate square access cover on outside of bumper fascia on passenger side of vehicle. Push in on side of cover with arrow. Open access cover and allow cover to hang. (See Page 2 for diagram showing location of access cover.)
8. Fishwire 7/16" x 1 1/4" carriage bolt and CM-SP2 spacer through fascia access hole located in Step 7 and out enlarged hole in passenger side bumper beam. (See FISHWIRE TECHNIQUE diagram.)
9. Replace access cover from Step 7 by inserting arrow side of cover first and then pushing driver side of cover in until it snaps back into position.
10. Place supplied nut plates over bumper beam, as shown.
11. Raise hitch into position over exhaust.
12. Secure hitch with finger tightened 7/16" hex flange nuts, as shown. (Note: Be sure to slide hitch as far forward as possible but not so it rests on the weld seam on the vehicle bumper beams.)
13. Secure hitch to nut plates from Step 10, with finger tightened 1/2" x 5" hex bolts and 1/2" conical toothed washers, as shown.
14. Insert 7/16" x 1" carriage bolts through top of square holes behind receiver tube of hitch, as shown.
15. Raise mounting strap between vehicle crossmember, as shown.
16. Secure mounting strap to hitch with finger tightened 7/16" hex flange nuts, as shown.
17. Raise nut plate in front of vehicle crossmember.
18. Secure nut plate to mounting strap with finger tightened 1/2" x 2 1/2" hex bolts and 1/2" conical toothed washers, as shown.
19. Torque all 1/2" hardware to 75 lb-ft and all 7/16" hardware to 50 lb-ft.
20. Reinstall (2) screws removed in Step 3.
21. Raise exhaust back into position.
22. Remove wire from Step 2.

PERIODICALLY CHECK THIS RECEIVER HITCH TO ENSURE THAT ALL FASTENERS ARE TIGHT AND THAT ALL STRUCTURAL COMPONENTS ARE SOUND.