

# 14044 1997-03 FORD F-150, F-250 LIGHT DUTY (NEW BODY STYLE)

10/3/2012

GROSS LOAD CAPACITY WHEN USED AS A WEIGHT CARRYING HITCH: 10,000 LBS. TRAILER WEIGHT & 1,000 LBS. TONGUE WEIGHT.  
GROSS LOAD CAPACITY WHEN USED AS A WEIGHT DISTRIBUTION HITCH: 12,000 LBS. TRAILER WEIGHT & 1,200 LBS. TONGUE WEIGHT

**\*\*\*DO NOT EXCEED VEHICLE MANUFACTURER'S RECOMMENDED TOWING CAPACITY.\*\*\***

Parts List			
ITEM	QTY	PART NUMBER	DESCRIPTION
1	6	CM-SP1	.250 x 1.50 x 2.00" SQUARE HOLE SPACER
2	6	1/2 - 13 x 2"	CARRIAGE BOLT
3	6	HFN 1213	HEX FLANGE NUT

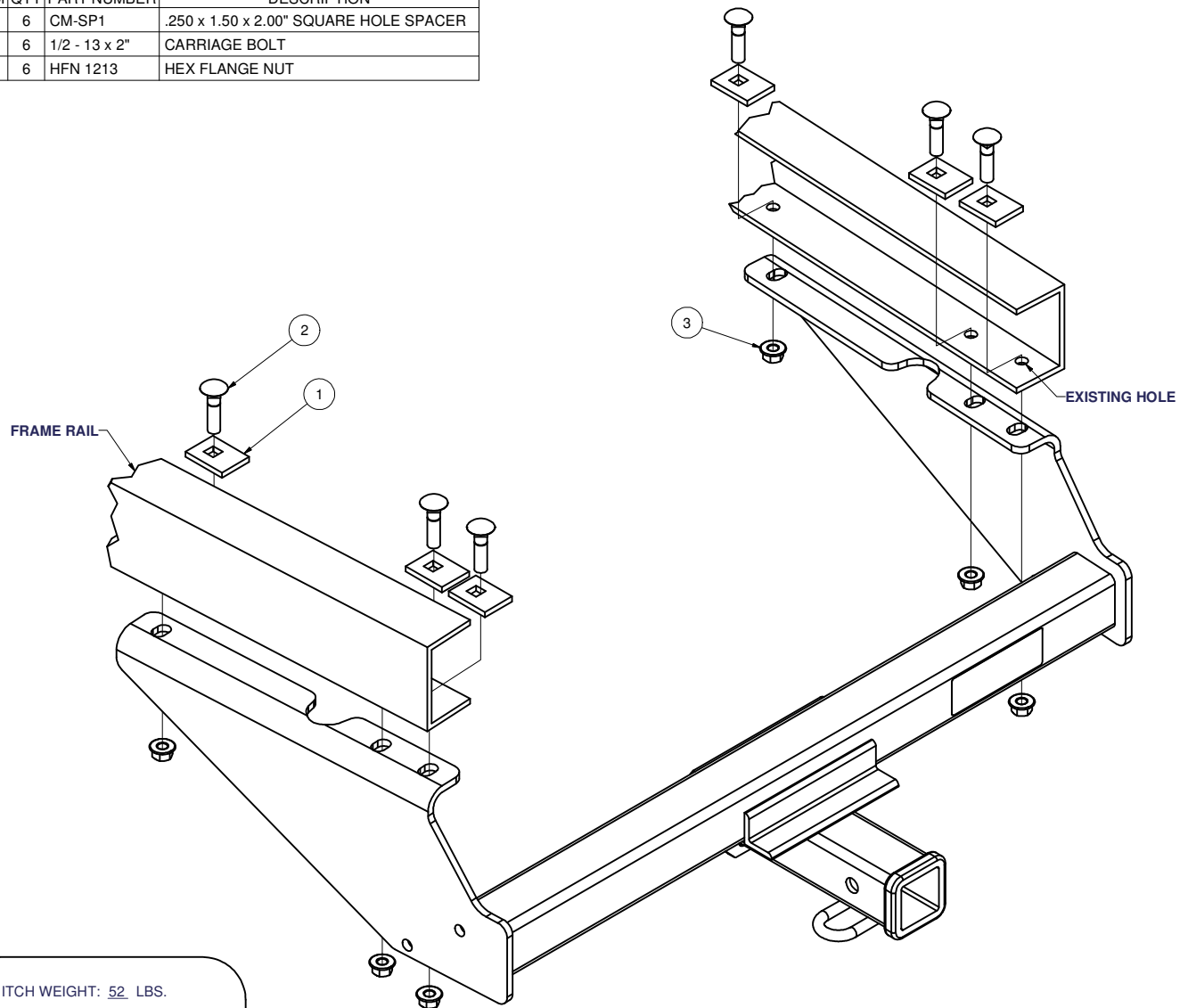

HITCH WEIGHT: 52 LBS.

INSTALL TIME: 30 MINUTES

INSTALL NOTES:

**NO DRILLING REQUIRED**

## INSTALLATION STEPS

- 1) Position the hitch against the frame. Align the holes in the hitch with holes in end of frame as shown.
- 2) Using the hardware provided, secure the hitch to the frame as shown.
- 3) Torque all hardware to 110 lb.-ft.

**PERIODICALLY CHECK THIS RECEIVER HITCH TO ENSURE THAT ALL FASTENERS ARE TIGHT AND THAT ALL STRUCTURAL COMPONENTS ARE SOUND.**

Curt Manufacturing Inc., warrants this product to be free of defects in material and/or workmanship at the time of retail purchase by the original purchaser. If the product is found to be defective, Curt Manufacturing Inc., may repair or replace the product, at their option, when the product is returned, prepaid, with proof of purchase. Alteration to, misuse of, or improper installation of this product voids the warranty. Curt Manufacturing Inc.'s liability is limited to repair or replacement of products found to be defective, and specifically excludes liability for incidental or consequential loss or damage.