



**Before returning this product
to the store of purchase**

Contact Dee Zee if you experience the following problems:

- Missing Parts
- Installation Problems/Questions
- Warranty Questions

1.800.779.2102

Hours of operation: 8am - 5pm CST, Mon-Friday

Review complete warranty policy and register your product at:

www.deezee.com



Dee Zee Wheel Well Toolbox Installation Instructions

Congratulations on your purchase of a quality Dee Zee product. Dee Zee is recognized as having the highest quality running boards and accessories on the market today. We have earned this reputation by offering our customers a product they can be proud to place on their vehicles. Dee Zee meets all the criteria of manufacturing a custom-fit product which guarantees it to be the easiest product to install.

Note: Please take time to read all of the instructions before beginning this installation.

Warning! Please check for wiring or other obstructions before drilling any holes into the vehicle. If it is necessary to drill any holes into the vehicle, Dee Zee recommends putting a sealant or rust inhibitor around all holes drilled into the body of the vehicle.

Warning! It is the sole responsibility of the vehicle owner to check for tire clearance.

Warning! It is unlawful and dangerous to ride on running boards or side box boards while vehicle is in motion.

Cleaning instructions: To maintain the bright finish of your Dee Zee running boards, clean with a mild detergent and use a high grade automotive type wax. **DO NOT USE ABRASIVE CLEANERS ON THIS PRODUCT!**

If you should happen to have any questions with this product or you have an installation question, please feel free to call us at:

1-800-779-8222

If you would like to find out more information on Dee Zee's products, please feel free to visit our website at:

WWW.DEEZEE.COM

DZ 956 / DZ 958 Wheel well toolbox

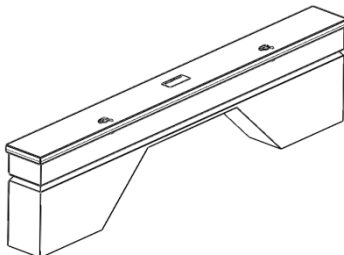
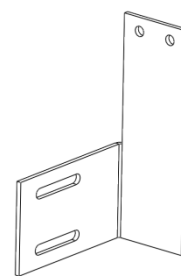
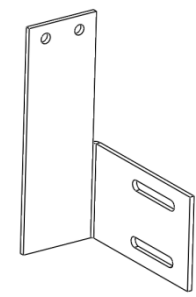
<p>A Wheel well toolbox</p>  <p>DZ 956</p>	<p>B Left Mounting Bracket</p>  <p>B 1102L X1</p>	<p>C Right Mounting Bracket</p>  <p>B 1102R X1</p>
--	---	--

<p>D 1/4" x 1" Black Sheet Metal Screw</p>  <p>PN 97B X4</p>	<p>E 1/4" X 3/4" Black Hex Head Bolt</p>  <p>PN 70B X8</p>	<p>F 1/4" Hex Nut</p>  <p>PN 71B X8</p>
--	--	---

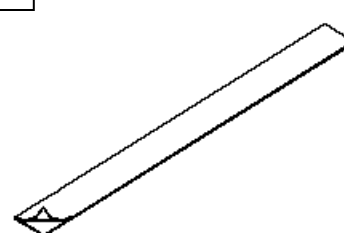
<p>G 1/4" Washer</p>  <p>PN 72B X8</p>	<p>H Foam Tape</p>  <p>X4</p>	
--	---	--

Tools Required

Ratchet / Wrench
13mm / 10mm
3/8"
7/16"

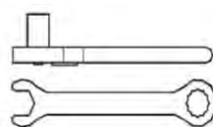



Drill Bit Sizes:
3/16"

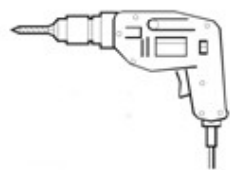

1

Peel the backing from the adhesive on the foam tape (H) and apply 2 pieces to each bottom surface of the wheel well toolbox. Place the wheel well toolbox (A) into the truck bed so that is center over the wheel well of the box. Making sure the box opens toward the inside of the box. The left and right mounting brackets (B/C) are mounting as shown. Mark the hole locations from the mounting brackets (B/C) on the inside lip of the bed rail and on the outside of wheel well toolbox.

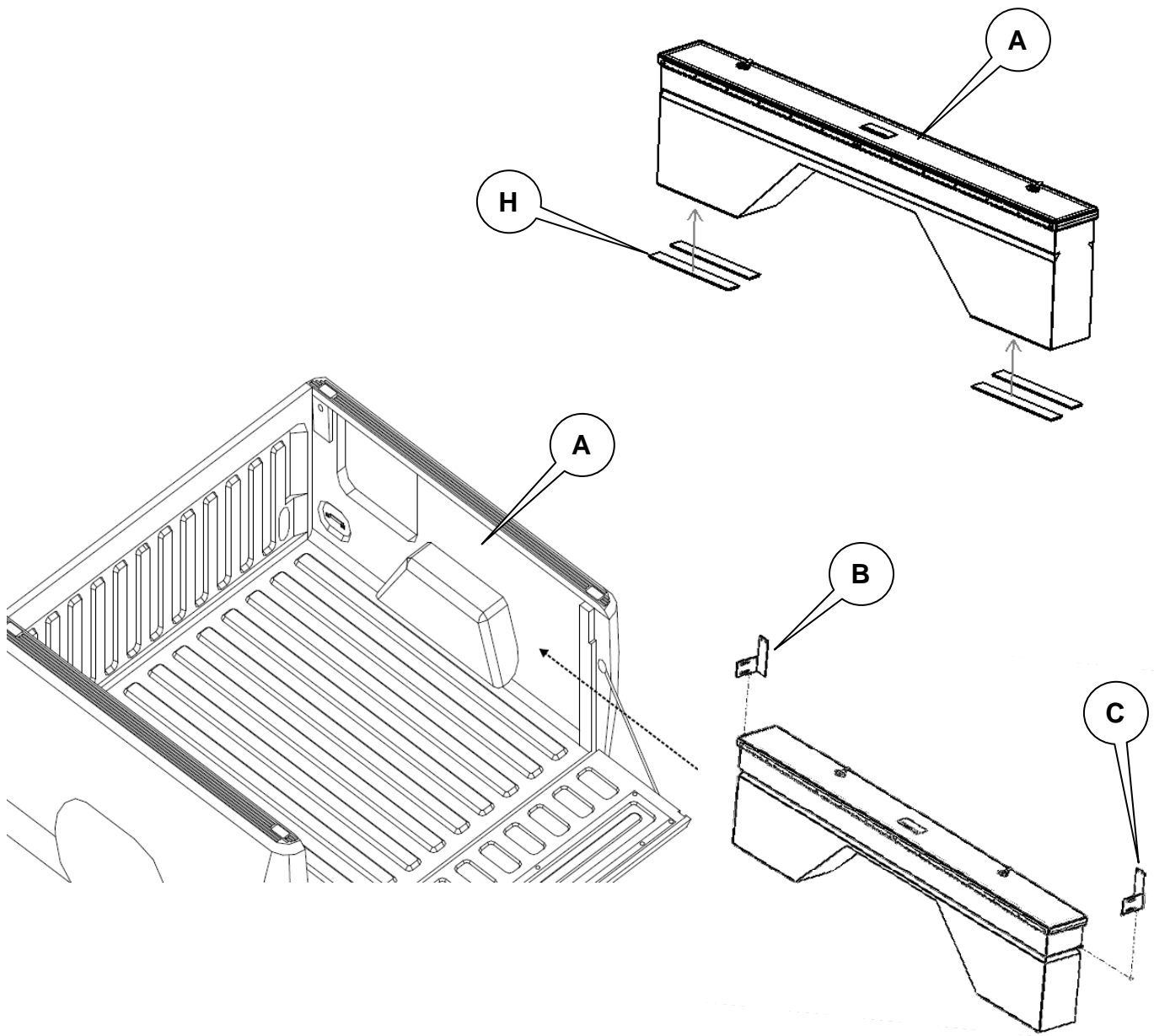

2

Remove the wheel well toolbox (A) from the vehicle bed and then use the marked hole locations as a guide to drill a ¼" hole through the inside lip of the bed rail as shown.

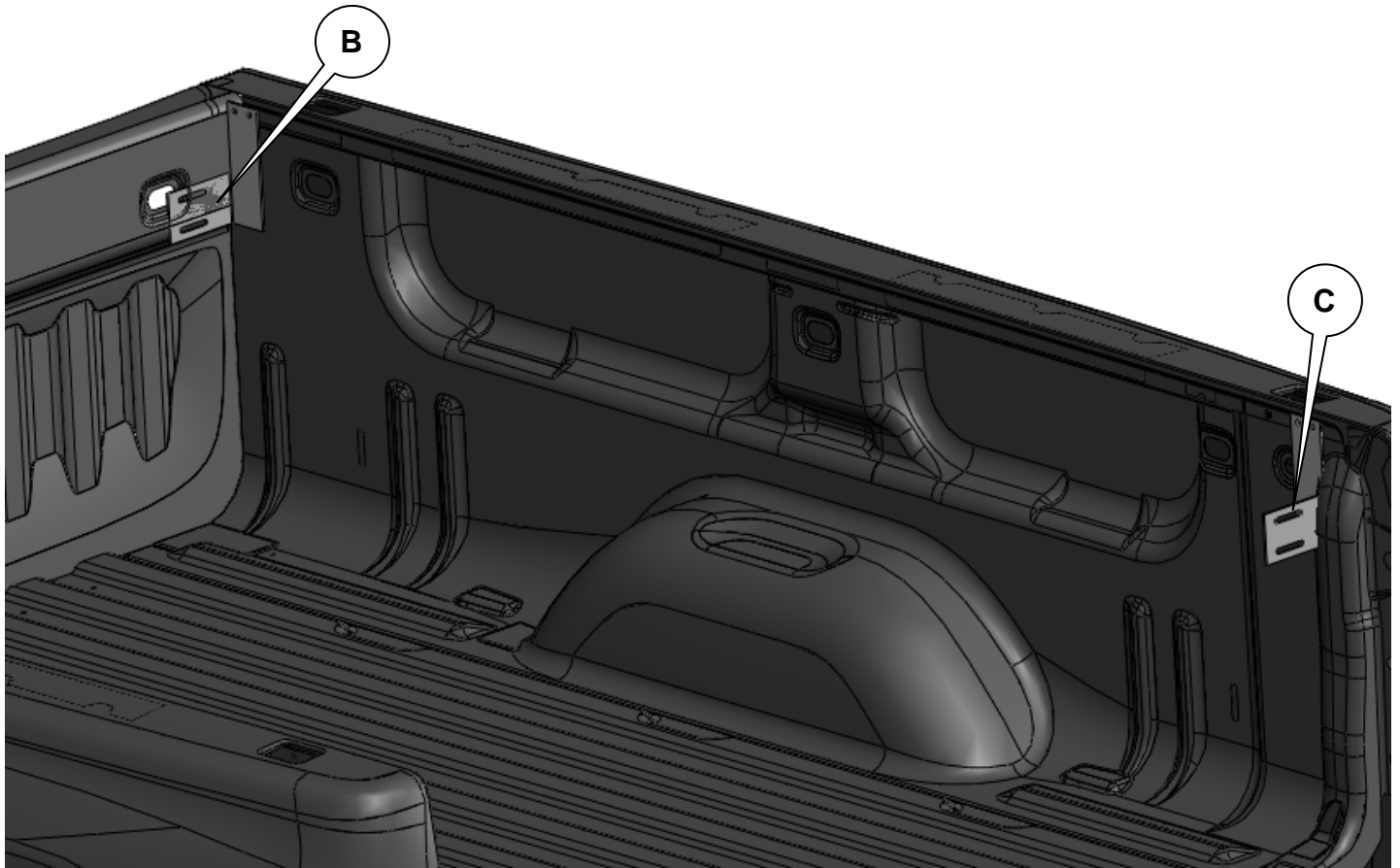

3

Secure mounting brackets (B/C) to the inside of the vehicle bed rail using ¼" x ¾" hex head bolts (E), ¼" flat washers (G) and ¼" hex nuts (F)

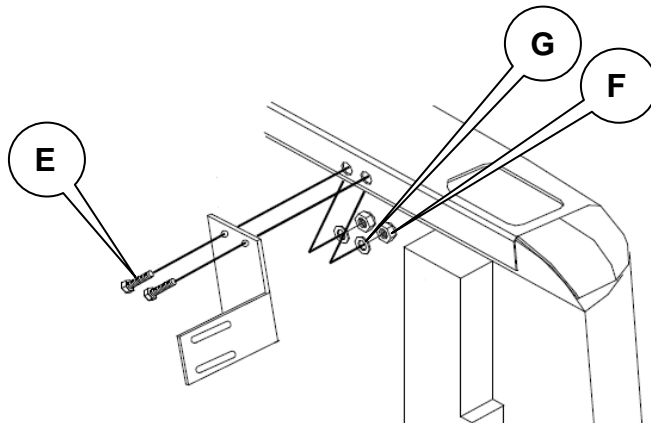

4

Place the wheel well toolbox (A) back into the truck bed inside of the mounting brackets (B/C) as shown below. Use the existing holes in the mounting brackets (B/C) as a guide to drill two ¼" holes through the outside of the wheel well toolbox (A).

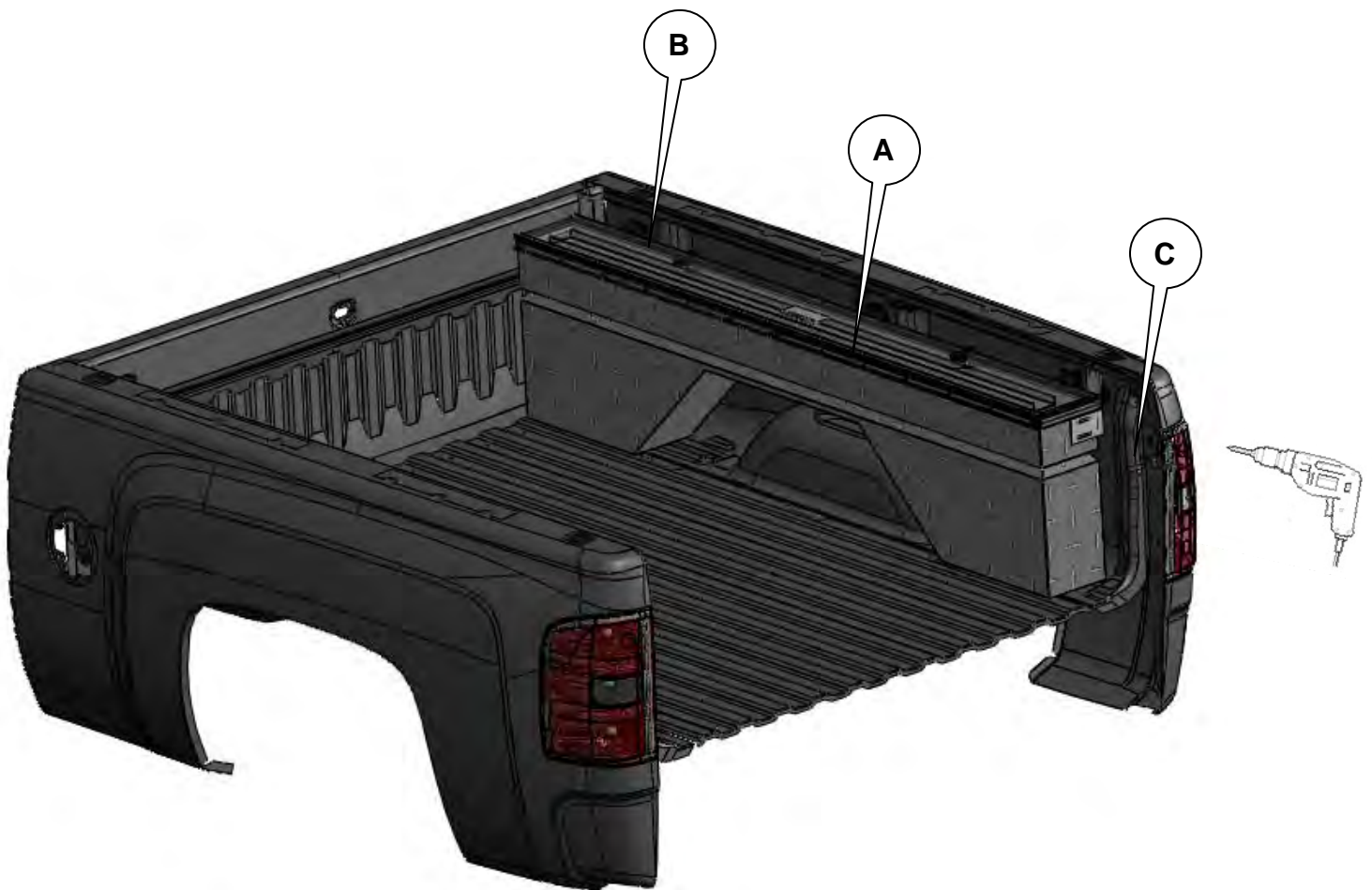

****REPEAT ON OPPOSITE SIDE IF USING TWO WHEEL WELL TOOLBOX'S****

MAINTENANCE INSTRUCTIONS: All locks, latches, latching rods, and hinges should be lubricated regularly to assure smooth and proper operation for the life of the toolbox.

INSTRUCTIONS D'Entretien: Toutes les serrures, verrous, verrouillant des tiges, et des charnières devraient être lubrifiées régulièrement pour assurer l'exécution sans heurt et appropriée pendant la vie de la boîte à outils.

.....
Ever lose your keys? Save Yourself Time and Trouble?

Order some extra keys now and have them when you need them. Please fill out and mail this portion to us. We'll send you a couple of extra keys for your Tool Box for just \$11.00 (American).

Name: _____

Day Phone: _____ - _____ - _____

Address: _____

Method of Payment:

Cash, Check, or Money Order

Master Card

Visa

City, State, Zip: _____

Expiration Date: _____

KEY and LOCK#: _____

Card Number: _____

Please mail form and payment to : Dee Zee, Inc.

OR P.O. Box 3090

Fax to: 515-265-7926

Des Moines, IA 50316

CLEANING INSTRUCTIONS: To maintain the luster of your tool box, use a mild detergent.

****Locks are provided as a deterrent to inadvertent opening or easy access to the contents of your toolbox. Contents stored in the toolbox are the responsibility of the user. Dee Zee does not insure loss of contents.**

After drilling, Dee Zee recommends putting a sealant or rust inhibitor around all holes drilled into the body panel of the vehicle.

If you should incur any problems with the installation of this product, please feel free to call us at 1-800-779-8222. So that we may better serve you when you call, please have the W/O#, SEQUENCE#, and the DATE from the label on the outside of the box. f