



## **INSTALLATION INSTRUCTIONS**

Congratulations – your new Work-Rite load assists are quality products capable of improving the handling and comfort of your vehicle while under load. As with all products, proper installation is the key to obtaining all of the benefits your kit is capable of delivering. Please take a few minutes to read through the instructions to identify the components and learn where and how they are used. It is a good idea to start by comparing the parts in your kit with the parts list below.

***NOTE: IF ANY PARTS ARE MISSING FROM THE KIT,  
PLEASE CALL 1-800-888-0650.  
PLEASE DO NOT CALL OR RETURN THE KIT TO THE DEALER.***

Be sure to take all applicable safety precautions during the installation of the kit. The instructions listed in this brochure and the illustrations all show the left, or driver's side of the vehicle. To install the right side assembly simply follow the same procedures.

### **STEP 1 – PREPARE THE VEHICLE**

With the vehicle on a solid, level surface chock the front wheels. Remove the negative battery cable. Remove the jounce bumpers located under the frame rail. The jounce bumpers will not be re-used with this kit but the bolts will be reused.

### **STEP 2 – ATTACH THE UPPER BRACKET TO THE VEHICLE**

Attach the upper bracket to the vehicle using bolt from the jounce bumper removal inserted through the large hole in the bottom of the bracket, and into the jounce bumper hole on the bottom of the frame. **See Figure "A"**.

### **STEP 3 – INSTALLING THE WORK-RITE ONTO THE BRACKET**

Select one Work-Rite load assist from your kit. Insert a 3/8"-16 x 1-1/5" bolt and flat washer through the bottom of the Work-Rite and into the small hole in the top. Fasten the Work-Rite to the upper bracket using a flange lock nut. **See Figure "A"**.

***NOTE: An optional spacer may be installed to engage the Work-Rite sooner when a load is applied. To install, place between the Work-Rite and the upper bracket. If the spacers are installed, use the 3/8"-16 x 2-1/2" bolts instead of the 3/8"-16 x 1-1/5" bolts. There should be 1/4" to 3/8" between the Work-Rite and the jounce stop (most 4x4's) or the axle (most 4x2's). See Figure "B"***.

### **STEP 4 – FINISH UP**

Remove the wheel chocks and reconnect the battery cable. Now you're finished and ready to put your Work-Rite to use!

## **PARTS LIST**

WORK-RITE LOAD ASSISTS	1258	2	3/8"-16 X 2-1/2" HEX BOLT	2
UPPER BRACKET	5627	2	3/8"-16 FLANGE LOCK NUT	4
OPTIONAL SPACERS	0013	4	3/8" FLAT WASHERS	2
3/8"-16 X 1-1/5" HEX BOLT		2		

Figure "A"

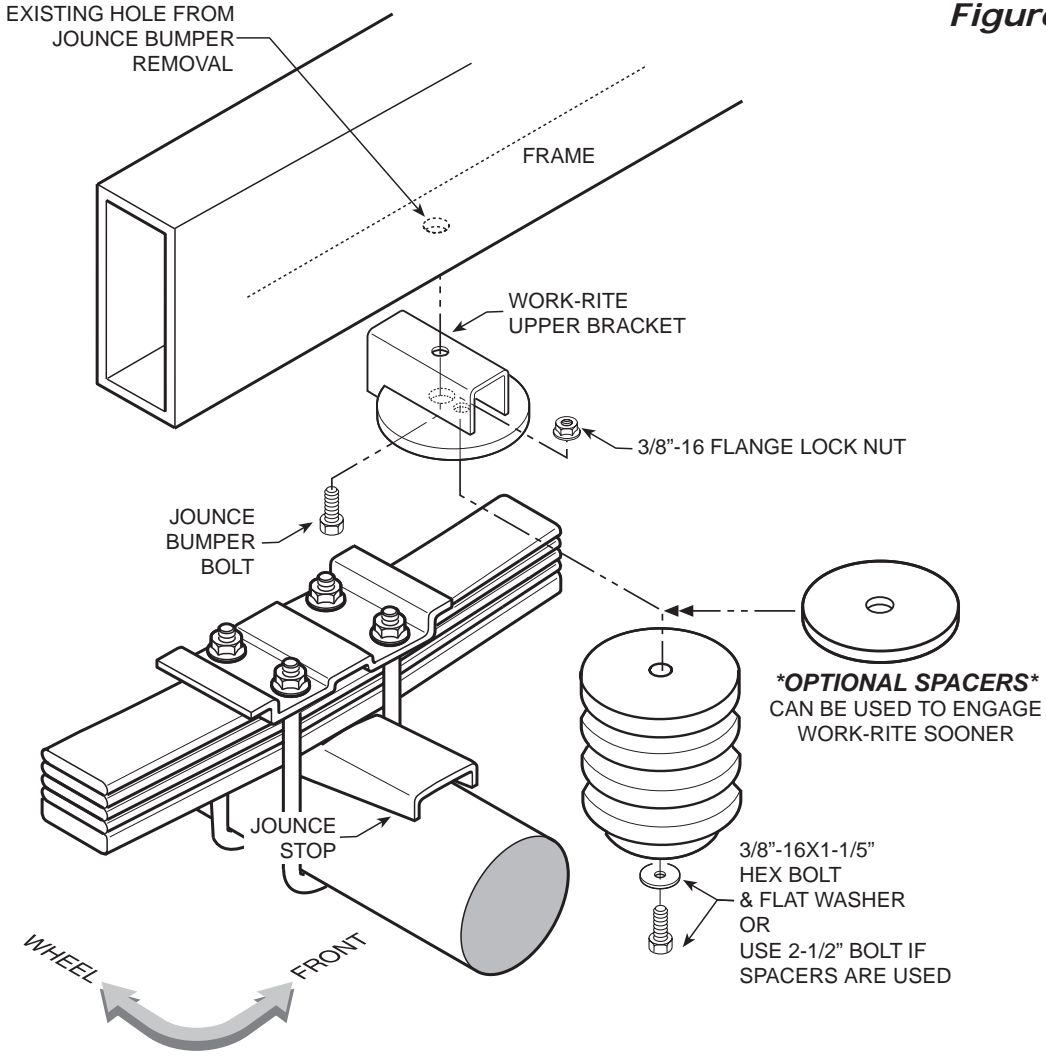

Figure "B"

