

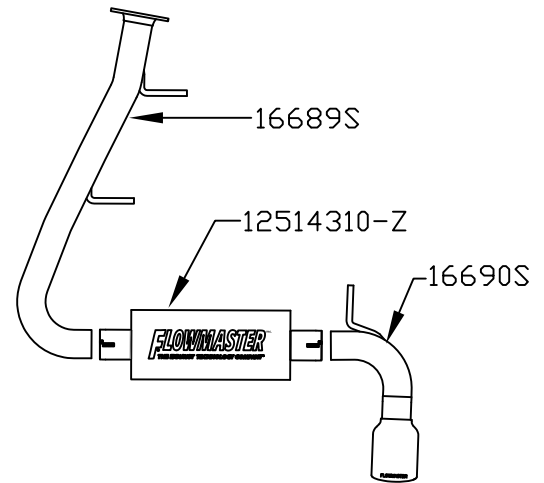

Installation diagram for:
SYSTEM #819122
2005-2010 SCION TC
2.4L Engine

dBX^{series}

409S Stainless Steel



1) Raise the vehicle up on a hoist or rack to working height. If you do not have access to a hoist or rack raise the vehicle and support securely with jack stands.



2) Use a penetrating fluid on the nuts at the flange connection as well as the rubber hangers to ease removal. Support the muffler with a stand and remove the two bolts at the flanged connection just forward of the rear axle. These bolts will be reused with the new Flowmaster system. Then remove the three hangers on the factory system from the rubber mounts on the vehicle, lower the muffler assembly from the vehicle and set aside.

3) Before installing anything, prep the clamps supplied in the hardware kit by removing the nuts, and applying a thick lubricant such as white grease or anti-seize to the threads.



4) Using the 3/8" bolt, nut and washers provided in the parts kit, bolt hanger **#420HA** to the rear axle in the hole indicated by the photo at left. Tighten securely. Then place the provided **#HA168** rubber hanger onto the round stock portion of hanger of **#420HA**.



5) Place inlet pipe **#16689S** into position behind the factory flange and connect the two hangers on the pipe to the rubber mounts on the vehicle. Then using the two M10x1.25 hex nuts provided, re-install the two bolts removed in step 2 above and tighten securely.



6) Place a provided 2.50" clamp onto the inlet of muffler **#12514310-Z** and slide onto inlet pipe **#16689S**. Support the muffler with a stand and tighten the clamp enough to hold the muffler in position, but still allow for adjustment.



7) Place a provided 2.50" clamp onto the outlet of the muffler, then place exit pipe **#16690S** into the outlet and connect the hanger on the pipe to the rubber mount on the vehicle. Tighten the clamp enough to hold, but still allow for adjustment.

Adjust the position of all pipes and muffler to provide a satisfactory fit. A minimum 3/4" clearance around all parts of the system must be maintained; while also keeping suspension travel and vibration in mind.

Tighten the two clamped connections securely. Slide the one 7/16" hanger keeper onto the middle hanger of the system and the two 1/2" hanger keepers onto the front and exit pipe hangers of the system. These will prevent the hangers from slipping out of the rubber mounts.

For a cleaner appearance and more secure installation, we recommend welding all slip-fit connections.

PACKING LIST

<u>Qty</u>	<u>Description</u>	<u>Part#</u>
1	Inlet Pipe	16689S
1	Muffler	12514310-Z
1	Exit Pipe	16690S
1	Parts kit	PK584
1	Frame Hanger	420HA
1	Rubber Hanger	HA168
2	2 1/2" clamp	MC250BS
2	M10 x 1.25 Hex Nut	HW110
1	3/8"x 1" bolt	HW208
1	3/8" Nut	HW103
1	3/8" lock washer	HW309
2	3/8" Flat Washer	HW303
1	7/16" Hanger Keepers	HW502
2	1/2" Hanger Keepers	HW503