

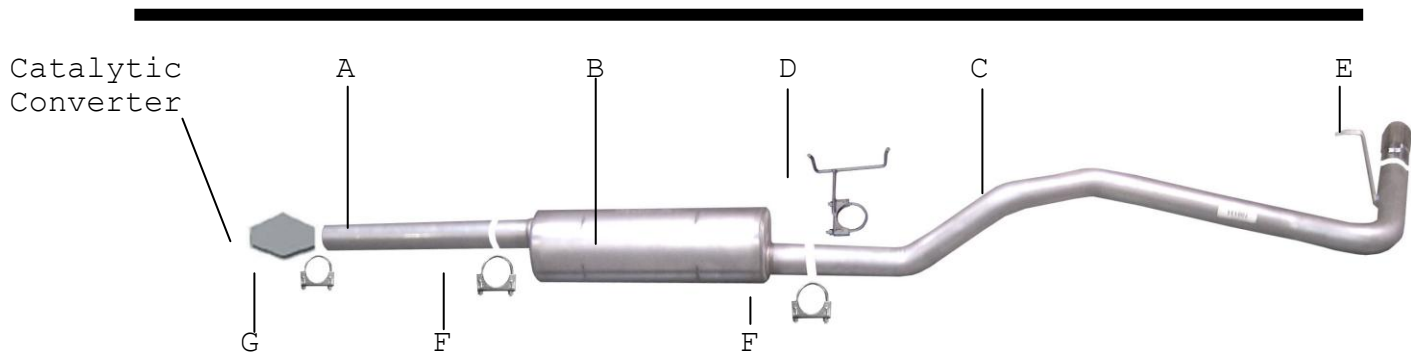

INSTRUCTION MANUAL
CAT-BACK SINGLE EXHAUST
TOYOTA TACOMA TRUCK 2.4L 2WD
EXTENDED CAB, SHORT BED

PART # 18400



ITEM	PART #	QTY	DESCRIPTION
A	700130	1	2-1/2" X 16" HEADPIPE
B	788200	1	SUPERFLOW MUFFLER
C	700131	1	2-1/2" TAILPIPE W/ HANGER
D	4131	1	REAR MUFFLER HANGER
E	500361	1	3" STAINLESS TIP
F	5757	2	2-1/2" CLAMP
G	5756	1	2 1/4" CLAMP

Thank you for purchasing our GIBSON EXHAUST SYSTEM for your vehicle.
If you need further assistance, please do not hesitate to call our
Technical Department at (800) 528-3044, Monday through Friday, 8:00 am
to 5:00 PM.

INSTALLATION INSTRUCTIONS

PART #18400

WHEN INSTALLING THIS EXHAUST SYSTEM MAKE SURE TO USE ALL THE PROPER SAFETY PRECAUTIONS. USE JACK STANDS WHEN UNDER TRUCK, SET PARKING BRAKE, BLOCK TIRES AND USE SAFETY GLASSES. DO NOT WORK WITH HOT PIPES!

SUGGESTED TOOLS:

Hacksaw, Jack Stand, 9/16 Socket, $\frac{1}{2}$ Socket, $\frac{1}{2}$ Wrench

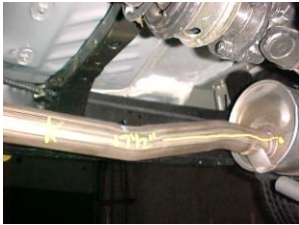

LAY OUT THE GIBSON EXHAUST ON THE FLOOR SO IT LOOKS LIKE THE PICTURE. TO REMOVE OUR STOCK EXHAUST MEASURE 17 $\frac{1}{2}$ " FROM THE FRONT OF THE MUFFLER TOWARDS THE MOTOR AND THEN CUT.



INSTALL TAILPIPE # C INTO MUFFLER 1-1/2" TO 2". SLIDE WELDED HANGER INTO RUBBER GROMMET USE CLAMP # F TO SECURE PIPE TO MUFFLER. DO NOT TIGHTEN



INSTALL HEADPIPE # A ONTO YOUR STOCK PIPE 1 $\frac{1}{2}$ TO 2" USE CLAMP # G TO SECURE PIPES TOGETHER. DO NOT TIGHTEN.



INSTALL REAR MUFFLER HANGER # D INTO RUBBER GROMMETS, LOCATED ABOVE OUTLET OF MUFFLER CLAMP TO TAILPIPE.



INSTALL MUFFLER # B ONTO HEADPIPE 1 $\frac{1}{2}$ " TO 2". THE MUFFLER INLET IS LOOKING INTO THE LOUVERS. THIS SHOULD BE AT THE 12 O'CLOCK POSITION. USE CLAMP # F TO SECURE MUFFLER TO THE HEADPIPE. DO NOT TIGHTEN.



INSTALL YOUR STAINLESS TIP TO YOUR DESIRED LOOK. NOW GO BACK AND TIGHTEN ALL CLAMPS FROM THE FRONT WORKING YOUR WAY BACK.

- MAKE SURE YOU HAVE A 1" CLEARANCE ON ALL PIPES FROM ALL RUBBER BRAKE LINES, SHOCK BOOTS, TIRES, ETC.

18400 TECHNICAL LOG