



PERFORMANCE EXHAUST SYSTEMS

INSTRUCTION MANUAL

CAT-BACK SINGLE EXHAUST SYSTEM

DODGE RAM 5.7L HEMI
RUMBLE BEE 1500 TRUCK, 2WD
STANDARD CAB, SHORT BED 2DR
PART# 316597

DO NOT
REMOVE
STOCK PIPE

CATALYTIC
CONVERTER

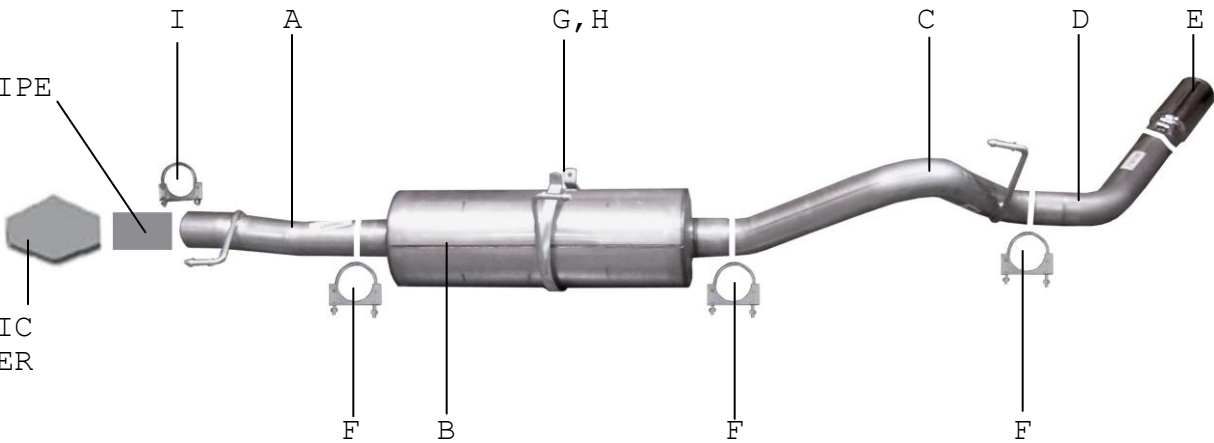

ITEM	PART #	QUANTITY	DESCRIPTION
A	700591	1	3"x21" HEADPIPE EXT. W/HANGER
B	766302	1	SUPERFLOW MUFFLER
C	700608	1	3" OVERAXLE TAILPIPE W/HANGER
D	50032R-2	1	3" EXIT PIPE
E	500542	1	4" STAINLESS TIP
F	OHD300	3	3" CLAMP
G	4187	1	BAND CLAMP
H	BO-1015	1	BAND CLAMP BOLT KIT
I	5758	1	2 3/4" CLAMP

SYSTEM MAY EXCEED 95 SOUND DECIBELS

Thank you for purchasing our GIBSON EXHAUST SYSTEM for your vehicle. If you need further assistance, please do not hesitate to call our Technical Department at (800) 528-3044, Monday through Friday, 8:00 am to 5:00 pm.

EXHAUST INSTALLATION #316597

WHEN INSTALLING THIS EXHAUST SYSTEM MAKE SURE TO USE PROPER SAFTEY PRECAUTIONS. USE JACK STANDS WHEN UNDER THE TRUCK, SET PARKING BRAKE, BLOCK TIRES AND USE SAFTEY GLASSES AND GLOVES. **DO NOT WORK WITH HOT PIPES!**

SUGGESTED TOOLS:

1/2" WRENCH, 9/16" SOCKET, 15MM SOCKET, HACKSAW, JACKSTAND, WD-40



LAY OUT THE EXHAUST ON THE FLOOR SO IT LOOKS LIKE THE DRAWING AND COMPARE PARTS TO THE MANUAL. TO REMOVE THE STOCK EXHAUST UN-CLAMP IT JUST IN FRONT OF THE MUFFLER. **DO NOT REMOVE THE STOCK HEADPIPE.** YOU MAY NEED TO HEAT IT UP FOR EASIER REMOVAL. LEAVE ALL RUBBER GROMMETS IN



INSTALL THE OVERAXLE TAILPIPE #C INTO THE MUFFLER 1-1/2" TO 2". INSERT WELDED HANGER INTO RUBBER GROMMET. USE CLAMP #F TO SECURE TAILPIPE TO THE MUFFLER. DO NOT TIGHTEN.



INSTALL HEADPIPE #A ONTO YOUR EXISTING STOCK FRONT PIPE AND SECURE WITH CLAMP #I. USE A JACKSTAND TO SUPPORT THE CONVERTER. INSERT WELDED HANGER INTO RUBBER GROMMET.



INSTALL EXIT PIPE #D ONTO OVERAXLE PIPE. ROLL TURNOUT PIPE UNTIL YOU HAVE IT AT THE CORRECT ANGLE FOR YOUR TRUCK AND CONNECT WITH CLAMP # F. BUT DO NOT TIGHTEN.



INSTALL MUFFLER #B ONTO HEADPIPE #A 1-1/2" TO 2" WITH THE LOUVERS FACING TOWARDS THE CONVERTER. USE A JACK STAND TO SUPPORT THE MUFFLER. USE CLAMP #F TO SECURE THE MUFFLER TO THE HEADPIPE. DO NOT TIGHTEN. MUFFLER INLET IS LOOKING INTO THE LOUVERS.



INSTALL STAINLESS STEEL TIP. WHEN YOU HAVE EVERYTHING IN PLACE, FIRMLY TIGHTEN ALL BOLTS AND CLAMP DOWN SECURELY. TO CLEAN STAINLESS STEEL TIP USE ANY STAINLESS STEEL CLEANER AND SCOTCH BRITE PAD.



SLIDE BAND CLAMP #G ONTO MUFFLER #B. INSERT HANGERS INTO RUBBER GROMMETS.

MAKE SURE YOU HAVE A 1" CLEARANCE ON ALL RUBBER BRAKE & FUEL LINES, SHOCK BOOTS, TIRE, ETC...