

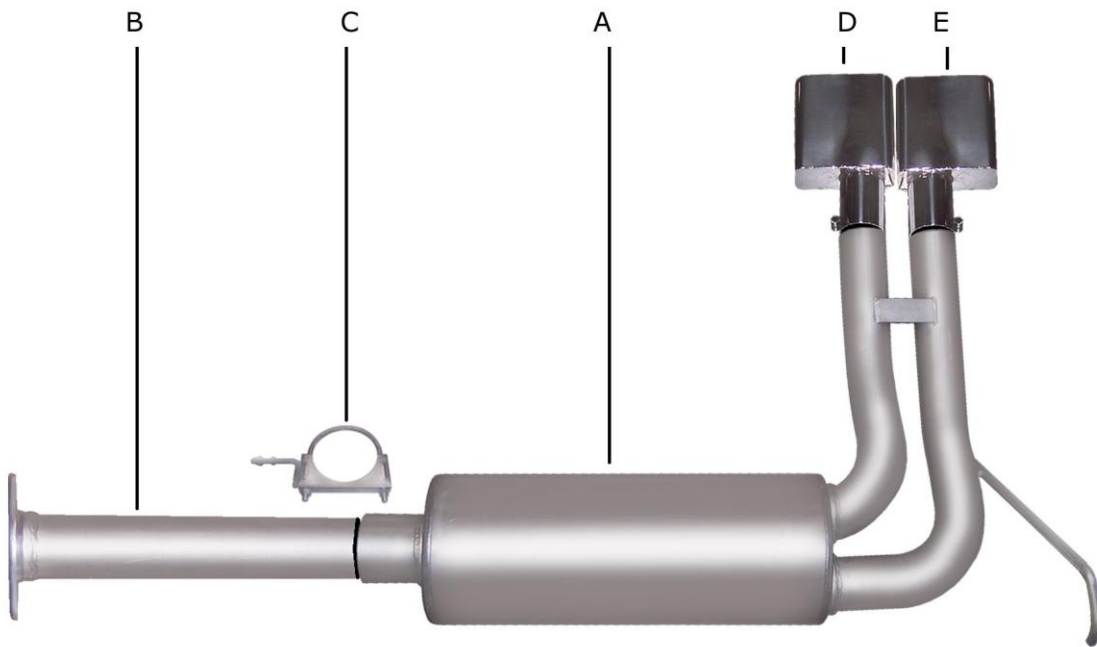

INSTRUCTION MANUAL
SUPER TRUCK EXHAUST
CHEVY 1500 TRUCK 4.3L, 5.0L, 5.7L 4WD
STANDARD CAB, SHORT BED
PART # 5517



ITEM	PART #	QUANTITY	DESCRIPTION
A	700111	1	MUFFLER ASSEMBLY
B	500165-A	1	HEADPIPE WITH FLANGE #GP-105
C	500440	1	O.E. HANGER
D	500365	1	SUPER TRUCK TIP
E	500366	1	SUPER TRUCK TIP

Thank you very much for purchasing our GIBSON PERFORMANCE EXHAUST SYSTEM for your vehicle. If you need further assistance, please do not hesitate to call our Technical Department at 800-528-3044, Monday through Friday, 8:00 am to 5:00 pm

EXHAUST INSTALLATION SHEET

WHEN INSTALLING THIS EXHAUST SYSTEM, MAKE SURE TO USE PROPER SAFETY PRECAUTIONS. USE JACK STANDS WHEN UNDER THE TRUCK, SET PARKING BRAKE, BLOCK TIRES, AND USE SAFETY GLASSES AND GLOVES. **DO NOT WORK WITH HOT PIPES!**

SUGGESTED TOOLS:

HACKSAW, 9/16" SOCKET, 1/2" SOCKET, 1/2" WRENCH, JACKSTAND

LAYOUT THE EXHAUST ON THE FLOOR AND COMPARE PART NUMBERS WITH THE MANUAL.



TO REMOVE EXHAUST- UNBOLT THE 2 BOLT FLANGE LOCATED BEHIND THE CATALITIC CONVERTER. **SAVE STOCK NUTS AND BOLTS FOR YOU WILL REUSE THEM.** NOW CUT OFF YOUR STOCK TAILPIPE JUST BEHIND THE MUFFLER AND REMOVE. LEAVE ALL RUBBER GROMMETS ON THE HANGER. USE WD-40 TO AID IN THE REMOVAL OF THE EXHAUST AND HANGERS.

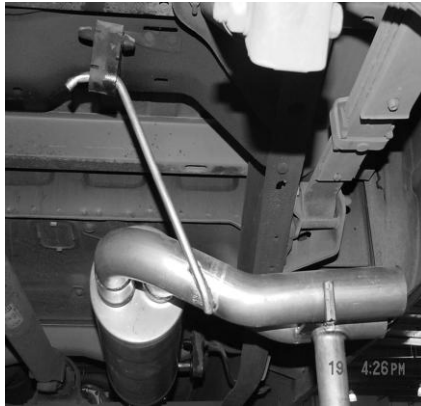

SLIDE MUFFLER ASSEMBLY ONTO HEADPIPE 1 1/2" TO 2". INSERT WELDED HANGER INTO RUBBER GROMMET ON DRIVERSIDE USE CLAMP #C TO SECURE MUFFLER TO HEADPIPE. DO NOT TIGHTEN.



BOLT HEADPIPE #B TO STOCK FLANGE RE-USING STOCK NUTS AND BOLTS. INSERT WELDED HANGER INTO RUBBER GROMMETS.

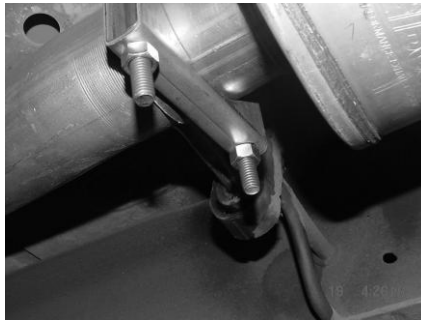

ADJUST MUFFLER ASSEMBLY. NOW TIGHTEN ALL BOLTS AND CLAMPS.



INSTALL STAINLESS TIPS. TO CLEAN TIPS, USE SCOTT BRITE PAD AND ANY STAINLESS AND ALUMINUM CLEANER.

MAKE SURE YOU HAVE A 1" CLEARANCE ON ALL PIPES FROM ALL BRAKE, FUEL LINES, SHOCKS, TIRES, ETC...