



PERFORMANCE EXHAUST SYSTEMS

INSTRUCTION MANUAL
CAT-BACK SPLIT REAR EXHAUST
96-00 CHEVY TRUCK 5.7L HD, 7.4L 2/4WD
EXTENDED CAB, LONG BED
PART #5530

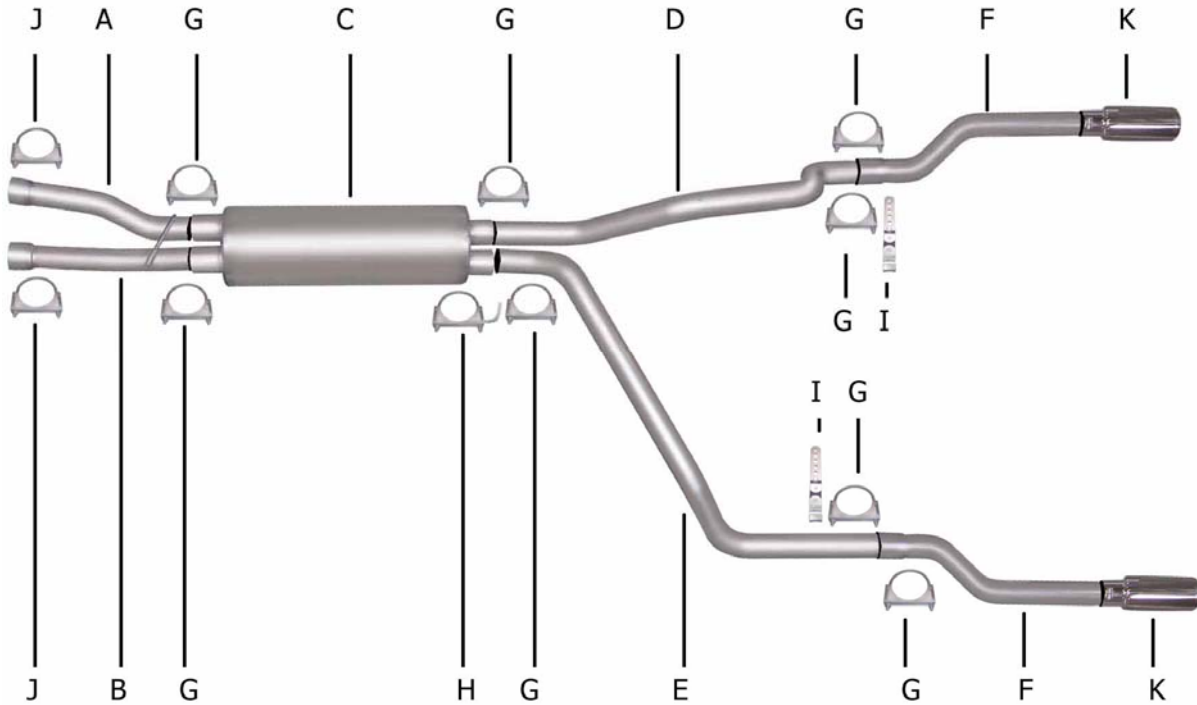

Table with 4 columns: ITEM, PART #, QTY., DESCRIPTION. Lists parts A through M with their respective part numbers, quantities, and descriptions.

Thank you for purchasing our GIBSON EXHAUST SYSTEM for your vehicle.
If you need further assistance, please do not hesitate to call our
Technical Department at 1-800-528-3044, Monday through Friday, 8:00 am
to 5:00 pm. 0306

INSTALLATION INSTRUCTIONS

WHEN INSTALLING THIS EXHAUST SYSTEM MAKE SURE TO USE PROPER SAFTY PRECAUTIONS USE JACK STANDS WHEN UNDER THE TRUCK, SET PARKING BRAKE, BLOCK TIRES, AND USE SAFTEY GLASSES AND GLOVES.
DO NOT WORK WITH HOT PIPES!

SUGGESTED TOOLS

HACK SAW, JACK STAND, 9/16" SOCKET & WRENCH, 1/2" SOCKET & WRENCH



LAY OUT THE GIBSON EXHAUST ON THE FLOOR SO IT LOOKS LIKE THE DRAWING AND COMPARE PART NUMBERS. FOR AN EASIER REMOVAL OF THE STOCK EXHAUST CUT THE TAILPIPE BEHIND THE MUFFLER. THEN CUT 18" IN FRONT OF THE STOCK MUFFLER AND REMOVE THE FACTORY EXHAUST. LEAVE ALL FACTORY RUBBER GROMMETS IN PLACE.



REMOVE THE REAR FACTORY HANGER. INSTALL HANGER #I TO THE BOTTOM STOCK HANGER HOLE. BOLT IT THROUGH THE 5TH HOLE DOWN FROM THE TOP OF THE HANGER. REPEAT ON THE DRIVER SIDE.

INSTALL DRIVER SIDE OVER AXLE PIPE #E. IT IS ROUTED BETWEEN THE SHOCK AND SPRINGS ABOVE THE AXLE. ATTACH TO MUFFLER WITH CLAMP #G AND HANGER #H.



INSTALL HEADPIPE'S A & B. SLIP HEADPIPE #B'S WELDED HANGER INTO THE FACTORY RUBBER GROMMET. ROTATE HEADPIPE'S UNTIL THEY ARE POSITIONED DIRECTLY NEXT TO EACH OTHER. USE CLAMPS #J TO ATTACH THEM TO THE FACTORY HEADPIPE. DO NOT TIGHTEN.



INSTALL OVER AXLE PIPE #D ON THE PASSENGER SIDE. **NOTE: THE SPARE TIRE MAY NEED TO BE LOOSENED AND PUSHED TO THE REAR OF THE TRUCK TO GAIN TAIL PIPE CLEARANCE. OVER AXLE PIPES WILL BE PARALLEL WITH THE FRAME RAIL AND OUT APROXIMATLEY 1/2".** USE CLAMP #G TO ATTACH PIPES D & E TO HANGERS #I



INSTALL MUFFLER #C. THE INLET OF THE MUFFLER WILL HAVE THE OPEN LOUVERS FACING FORWARD GRABBING THE EXHAUST. MAKE SURE THE MUFFLER OUTLETS ARE POSITIONED AT THE TOP OF THE MUFFLER. INSTALL HANGER #H ON THE DRIVER SIDE OUTLET OF THE MUFFLER OUTLET ON DRIVERSIDE. DO NOT TIGHTEN.



INSTALL THE EXIT PIPES #F TO YOUR DESIRED LOOK. ATTACH WITH CLAMPS #G. MAKE SURE YOU HAVE A MINIMUM OF A 1" CLEARANCE FROM ALL BRAKE LINES, TIRES, SHOCKS FUEL LINES, ETC. THEN TIGHTEN ALL CLAMPS AND HANGERS. NOW INSTALL THE STAINLESS STEEL TIPS USE SUPPLIED ZIP TIES TO TIE AWAY THE BRAKE AND FUEL LINES.

"MAKE SURE YOU HAVE A MINIMUM OF A 1" CLEARANCE FROM ALL RUBBER BRAKE LINE'S, TIRES, SHOCKS, ETC"