

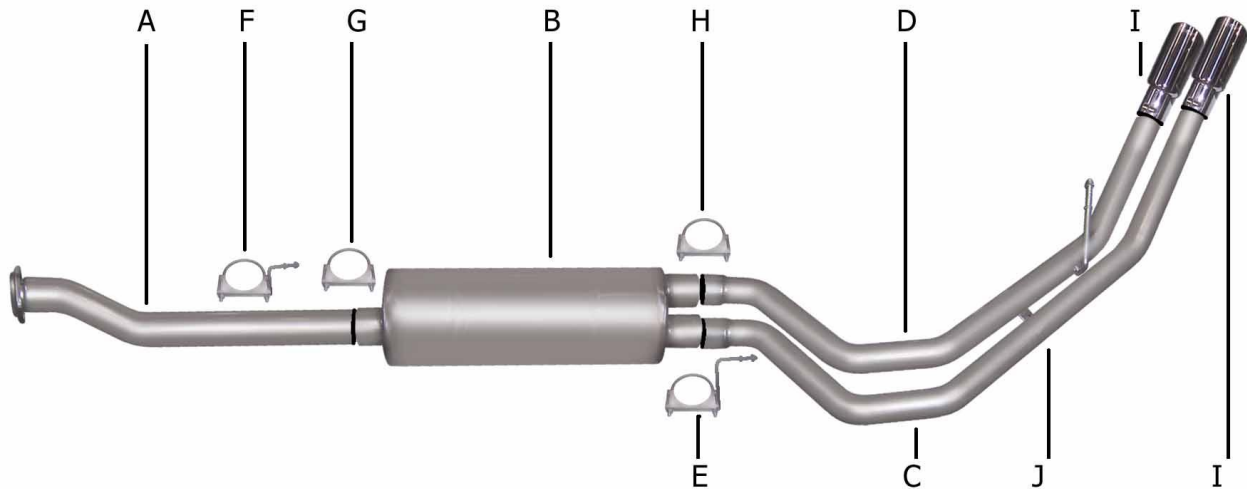

PERFORMANCE EXHAUST SYSTEMS

**INSTRUCTION MANUAL**  
**CAT-BACK DUAL SPORT EXHAUST**  
**SUBURBAN, YUKON XL 1500 2/4WD**  
**4.8L-5.3L**  
**PART# 5603**



ITEM	PART #	QUANTITY	DESCRIPTION
A	700307	1	HEADPIPE WITH FLANGE #GP-115
B	758250	1	SUPERFLOW MUFFLER
C	700302	1	2-1/4" OVERAXLE TAILPIPE
D	700303	1	2-1/4" OVERAXLE TAILPIPE
E	4148	1	REAR DRIVER SIDE TAILPIPE HANGER
F	4147	1	HEADPIPE HANGER
G	OHD300	1	3" CLAMP
H	5757	1	2-1/2" CLAMP
I	500370	2	3" STAINLESS TIPS
J	B0-906	1	BOLT KIT FOR TAILPIPE

Thank you for purchasing our GIBSON EXHAUST SYSTEM for your vehicle. If you need further assistance, please do not hesitate to call our Technical Department at 1-800-528-3044, Monday through Friday, 8:00 am to 5:00 PM.

# EXHAUST INSTALLATION

WHEN INSTALLING THIS EXHAUST SYSTEM MAKE SURE TO USE ALL THE PROPER SAFETY PRECAUTIONS. USE JACK STANDS WHEN UNDER TRUCK, SET PARKING BRAKE, BLOCK TIRES AND USE SAFETY GLASSES. DO NOT WORK WITH HOT PIPES!

## SUGGESTED TOOLS:

9/16" SOCKET, 1/2" WRENCH, 1/2" SOCKET, 15mm SOCKET, JACK STAND, HI-TEMP GASKET SEALER

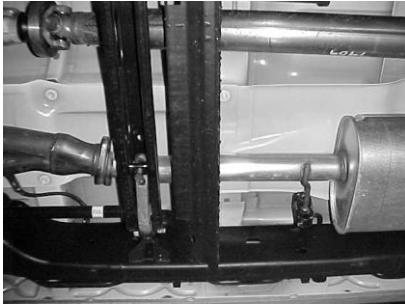

LAY OUT THE GIBSON EXHAUST AND COMPARE PART NUMBERS WITH THE MANUAL. FOR AN EASIER REMOVAL OF THE FACTORY EXHAUST CUT THE TAILPIPE BEHIND THE MUFFLER. THEN UN-BOLT THE FLANGE IN FRONT OF THE MUFFLER AND REMOVE. LEAVE ALL FACTORY RUBBER GROMMETS IN PLACE. **YOU WILL RE-USE THE FACTORY BOLTS.**

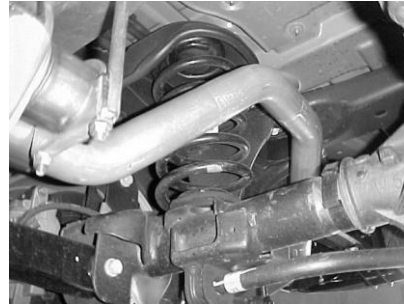

SLIP TAILPIPE # D INTO THE PASSENGER SIDE OUTLET NO MORE THEN 2" AND NO LESS THEN 1". THEN SLIP THE WELDED HANGER INTO THE FACTORY RUBBER GROMMET. USE CLAMP # H TO TIGHTEN THE CONNECTION AT THE MUFFLER OUTLET. DO NOT TIGHTEN CLAMPS.



CONNECT HEADPIPE # A TO THE FACTORY FLANGE, RE-USING THE FACTORY BOLTS. YOU MAY NEED TO APPLY A SMALL AMOUNT OF HI-TEMP GASKET SEALER TO THE FLANGE DOME TO INSURE A LEAK FREE CONNECTION.

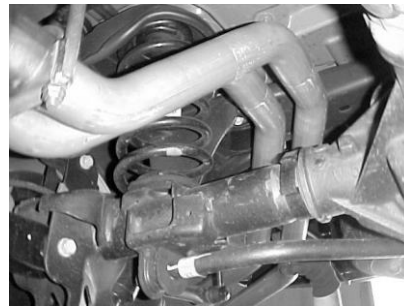

SLIP TAILPIPE #C INTO THE DRIVER SIDE OUTLET NO MORE THEN 2" AND NO LESS THEN 1". USE HANGER # E TO TIGHTEN THE CONNECTION AT THE MUFFLER OUTLET. DO NOT TIGHTEN

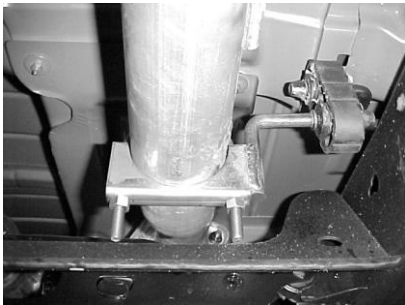

INSTALL HANGER # F ONTO HEADPIPE # A, AND INSERT WELDED HANGER INTO RUBBER GROMMET. DO NOT TIGHTEN.

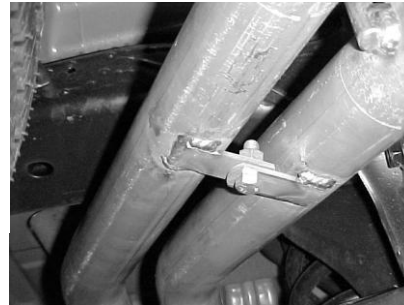

USING BOLT KIT #J AND ATTACH BOTH TAILPIPES. THE PASSENGER SIDE MOUNTING BRACKET WILL BE POSITIONED UNDERNEATH THE DRIVER SIDE.



SLIP MUFFLER # B ONTO HEADPIPE #A NO MORE THEN 1- 2" USE A JACK STAND TO SUPPORT THE MUFFLER. MAKE SURE THE MUFFLER OUTLETS ARE POSITIONED AT 8 O'CLOCK AND 4 O'CLOCK. NOW INSTALL HANGER #E ON THE DRIVER SIDE OUTLET, AND INSERT WELDED HANGER INTO RUBBER GROMMET. DO NOT TIGHTEN



NEXT INSTALL YOUR STAINLESS STEEL TIPS TO YOUR DESIRED LOOK. USE ANY ALUMINUM OR STAINLESS STEEL CLEANER TO POLISH YOUR TIP. **THEN TIGHTEN ALL CLAMPS AND HANGERS.**

**"MAKE SURE HAVE A MINIMUM OF A 1" ON ALL PIPES FROM ALL RUBBER BRAKE LINES, TIRES, SHOCKS, FUEL LINES, ETC."**