

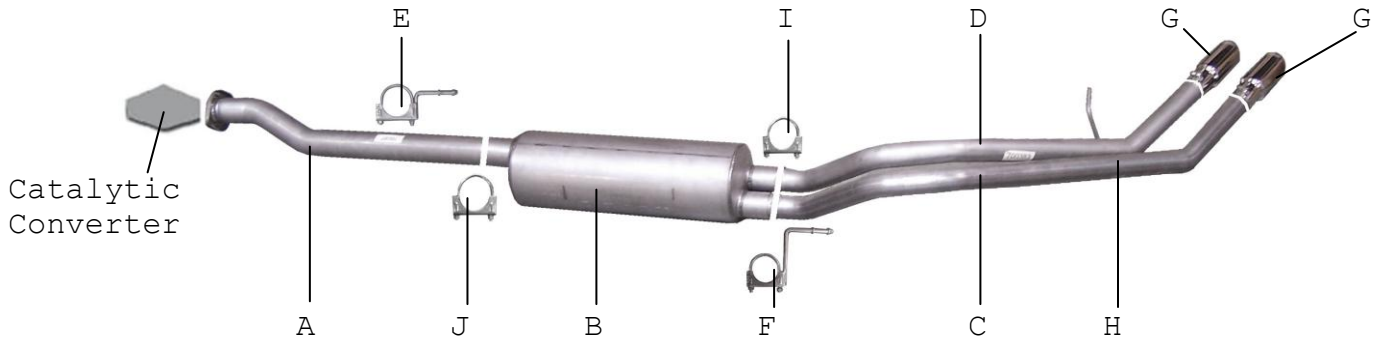

**INSTRUCTION MANUAL**  
**CAT-BACK DUAL SPORT EXHAUST**  
**CHEVY AVALANCHE 1500 5.3L 2/4WD**  
**CREW CAB, SHORT BED**  
**PART # 5702**



ITEM	PART#	QUANTITY	DESCRIPTION
A	700307	1	3" HEADPIPE W/FLANGE #GP-115
B	758250	1	SUPERFLOW MUFFLER
C	700382	1	2.25" DRIVERSIDE TAILPIPE
D	700383	1	2.25" PASSENGERSIDE TAILPIPE
E	4147	1	FRONT HEADPIPE HANGER
F	4181	1	REAR MUFFLER HANGER
G	500395	2	3-1/2" STAINLESS TIPS
H	BO-906	1	BOLT KIT FOR TAILPIPES
I	5757	1	2.5" CLAMP
J	OHD300	1	3" CLAMP

Thank you for purchasing our GIBSON PERFORMANCE EXHAUST SYSTEM for your vehicle. If you need further assistance, please do not hesitate to call our Technical department at 1-800-528-3044 Monday through Friday, 8:00 am to 5:00 pm.

# EXHAUST INSTALLATION #5702

WHEN INSTALLING THIS EXHAUST SYSTEM MAKE SURE YOU USE ALL THE PROPER SAFETY PRECAUTIONS. USE JACK STAND TO SUPPORT THE TRUCK WHILE OFF THE GROUND. SET PARKING BRAKE, BLOCK THE TIRES AND USE SAFETY GLASSES AND GLOVES.

**DO NOT WORK WITH HOT PIPES!**

## **SUGGESTED TOOLS:**

HACKSAW, JACKSTAND, 1/2" WRENCH & SOCKET, 15MM & 9/16" SOCKET & 9/16" WRENCH, WD-40



TO REMOVE THE STOCK EXHAUST UNBOLT IT FROM THE 2-BOLT FLANGE JUST BEHIND THE CONVERTER. FOR EASIER REMOVAL OF THE STOCK EXHAUST CUT THE STOCK TAILPIPE OFF JUST BEHIND THE MUFFLER. LEAVE ALL RUBBER GROMMETS ON THE HANGER. USE WD-40 TO AID IN REMOVAL OF THE EXHAUST AND HANGERS. **DO NOT DISGUARD HARDWARE YOU WILL RE-USE IT.**



INSTALL PASSENGER SIDE TAILPIPE #D INTO MUFFLER 1-1/2 TO 2". INSERT WELDED HANGER INTO RUBBER GROMMET. USE CLAMP #I TO SECURE THE TAILPIPE TO THE MUFFLER. DO NOT TIGHTEN.



INSTALL HEADPIPE #A ONTO STOCK FLANGE RE-USING FACTORY NUTS TO BOLT IT TOGETHER. INSTALL HANGER #E ONTO HEADPIPE. INSERT WELDED HANGER INTO RUBBER GROMMET. DO NOT TIGHTEN.



INSTALL DRIVERS SIDE TAILPIPE #C INTO THE MUFFLER 1-1/2" TO 2". USE BOLT KIT #H TO SECURE THE TAILPIPES TOGETHER. DO NOT TIGHTEN. DRIVER SIDE TAILPIPE WILL BE ON TOP OF PASSENGER SIDE TAB.



INSTALL MUFFLER #B ONTO HEADPIPE 1-1/2" TO 2". USE CLAMP #J TO SECURE THE MUFFLER TO THE HEADPIPE. DO NOT TIGHTEN. INSTALL REAR MUFFLER HANGER #F ONTO THE DRIVERSIDE MUFFLER OUTLET. INSERT WELDED HANGER INTO RUBBER GROMMET. DO NOT TIGHTEN.



INSTALL THE STAINLESS TIPS. NOW GO BACK AND TIGHTEN ALL THE CLAMPS, NUTS AND BOLTS STARTING FROM THE FRONT AND WORKING BACK. TO CLEAN THE TIPS USE ANY STAINLESS CLEANER AND A SCOTCH BRITE PAD.

**"MAKE SURE YOU HAVE A MINIMUM OF 1" CLEARANCE ON ALL PIPES FROM BRAKE LINES, FUEL LINES, SHOCKS, TIRES, ETC..."**