

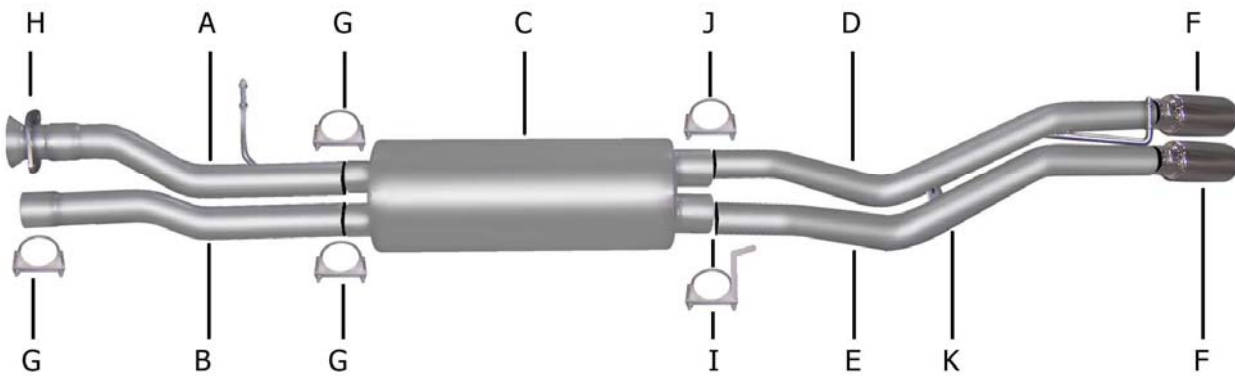

INSTRUCTION MANUAL
CAT-BACK STAINLESS DUAL REAR EXHAUST
03-06 HUMMER H2/SUT 6.0L, 4DR 4WD
PART # 612000



ITEM	PART #	QUANTITY	DESCRIPTION
A	575-700467S-1	1	2-1/2" STAINLESS PASS. SIDE HEADPIPE W/HANGER
B	576-700468S-1	1	2-1/2" STAINLESS DRIVER SIDE HEADPIPE
C	788701S	1	STAINLESS SUPERFLOW MUFFLER
D	667-700534S	1	2-1/4" STAINLESS OVERAXLE TAILPIPE W/HANGER
E	668-700535S	1	2-1/4" STAINLESS OVERAXLE TAILPIPE
F	500395	2	3-1/2" STAINLESS TIPS
G	5757	3	2-1/2" CLAMP
H	BO-1028	1	BOLT KIT FOR HEADPIPE
I	4227	1	2-1/4" REAR MUFFLER HANGER
J	5756	1	2-1/4" CLAMP
K	BO-906	1	BOLT KIT FOR TAILPIPES

Thank you for purchasing our GIBSON EXHAUST SYSTEM for your vehicle. If you need any further assistance, please do not hesitate to call our Technical Department at 1-800-528-3044 Monday through Friday, 8:00 AM to 5:00 PM 0706

EXHAUST INSTALLATION #612000

When installing this exhaust system make sure to use proper safety precautions. Use jack stands when under the truck, set parking brake, block tires and use safety glasses and gloves.

DO NOT WORK WITH HOT PIPES!

SUGGESTED TOOLS:

1/2" , 9/16" , 15mm Socket & Wrench, WD-40, Jack Stand, Hacksaw

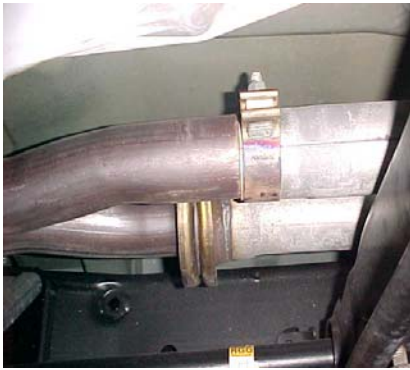

Lay out the exhaust on the floor so it looks like the drawing and compare parts with manual. To remove the stock exhaust remove it from the stock flange & slip joint located in front of the muffler, then cut off your tailpipe just behind the muffler.

Use WD-40 to aid in removal of hangers from grommets leave grommets on vehicle.



Install the passenger side over axle tailpipe # D into the muffler 1-1/2" to 2". Insert welded hanger into rubber grommet. Use clamp # J to secure pipe to muffler, do not tighten.



Install passenger side headpipe # A onto stock flange using hardware provided, do not tighten. Insert welded hanger into rubber grommet. Next, install driver side headpipe # B onto stock pipe, use clamp # G to secure together, do not tighten.



Next, Install Driverside tailpipe # E into muffler 1-1/2"- 2". Tab on pipe should be on the top, use bolt # K to secure pipes together.



Install rear muffler hanger # I onto driver side outlet of muffler. Insert hanger into rubber grommet. Do not tighten.



Install muffler #C onto head pipes #A-B 1-1/2" to 2" with the louvers facing towards the converter. Use a jack stand to support the muffler. Use clamps #G to secure the muffler to the head pipes. Do not tighten. Outlets of muffler should be on the bottom.



Install stainless steel tip. Clamp down. When you have everything in place, firmly tighten all bolts and clamp down securely. To clean stainless steel tip use any stainless steel cleaner and Scotch Brite pad.

**MAKE SURE YOU HAVE A 1" CLEARANCE ON ALL RUBBER BRAKE LINES, SHOCK BOOTS, TIRES, FUEL LINES, ETC..
TIGHTEN ALL CLAMPS TO 100 TO 150 FT. LBS.**