

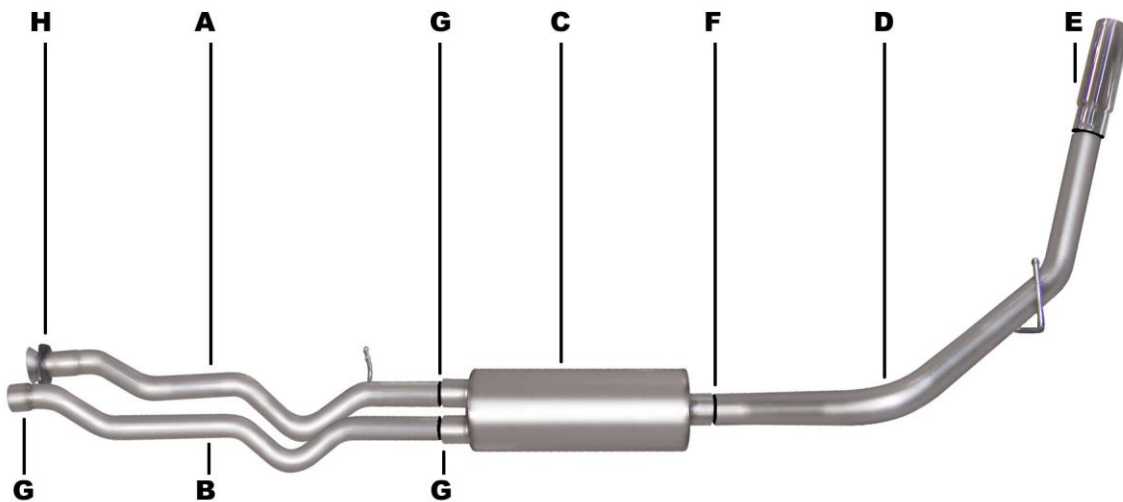

INSTRUCTION MANUAL
CAT-BACK SINGLE STAINLESS EXHAUST
CHEVY SILVERADO 1500SS TRUCK
6.0L AWD EXTENDED CAB, SHORT BED
PART # 615539



ITEM	PART #	QTY	DESCRIPTION
A	650-700512S	1	2 1/2" SS P/S HEADPIPE W/ FLANGE #GP-305
B	651-700513S	1	2 1/2" SS DRIVER HEADPIPE
C	758250S	1	SS SUPERFLOW MUFFLER
D	654-700516S	1	3" SS OVER-AXLE TAILPIPE W/ HANGER
E	500360	1	3-1/2" STAINLESS TIP
F	4224	1	REAR MUFFLER HANGER
G	5757	3	2 1/2" CLAMP
H	BO-1018	1	BOLT KIT FOR HEADPIPE

Thank you for purchasing our GIBSON EXHAUST SYSTEM for your vehicle. If you need further assistance, please do not hesitate to call our Technical Department at 1-800-528-3044 Monday through Friday, 8:00 am to 4:30 pm.

INSTALLATION INSTRUCTIONS#615539

WHEN INSTALLING THIS EXHAUST SYSTEM MAKE SURE TO USE ALL THE PROPER SAFETY PRECAUTIONS. USE JACK STANDS WHEN UNDER THE VEHICLE, SET THE PARKING BRAKE, BLOCK TIRES AND USE SAFETY GLASSES.
DO NOT WORK WITH HOT PIPES!!!

SUGGESTED TOOLS:

15MM SOCKET, 9/16" SOCKET, 1/2" WRENCH & SOCKET, JACKSTANDS, HACKSAW, WD-40

LAY OUT THE EXHAUST AND COMPARE THE PART NUMBERS TO THE MANUAL

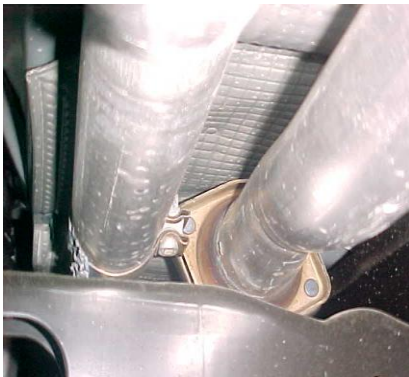

REMOVE YOUR STOCK EXHAUST FROM THE FACTORY FLANGES LOCATED JUST BEHIND YOUR FACTORY Y-PIPE, NEXT CUT OFF YOUR TAILPIPE JUST BEHIND THE MUFFLER. USE WD-40 TO AID IN REMOVAL OF RUBBER GROMMETS FROM HANGERS.



INSTALL REAR MUFFLER HANGER # F ONTO OUTLET OF MUFFLER. INSERT HANGER INTO RUBBER GROMMET.



INSTALL PASS. SIDE HEADPIPE # A ONTO FACTORY FLANGE USING THE HARDWARE # H. INSERT WELDED HANGER INTO RUBBER GROMMET. DO NOT TIGHTEN. NEXT INSTALL DR. SIDE HEADPIPE # B ONTO FACTORY PIPE USE CLAMP # G TO SECURE, DO NOT TIGHTEN.



INSTALL OVER-AXLE TAILPIPE # D INTO MUFFLER 1 1/2" - 2", INSERT WELDED HANGER INTO RUBBER GROMMET, ROTATE PIPE TO PROPER ANGLE.



INSTALL MUFFLER # C ONTO HEADPIPES 1 1/2"-2". USE CLAMPS # G TO SECURE OUTLET OF MUFFLER, IT SHOULD BE AT THE 12 O'CLOCK POSITION. USE A JACKSTAND TO SUPPORT MUFFLER.



INSTALL YOUR STAINLESS TIP TO YOUR DESIRED LOOK. NOW GO BACK AND TIGHTEN ALL NUTS, BOLTS, AND CLAMPS.

MAKE SURE YOU HAVE A 1" CLEARANCE FROM ALL BRAKE LINES, FUEL LINES, SHOCKS, TIRES, ETC.