

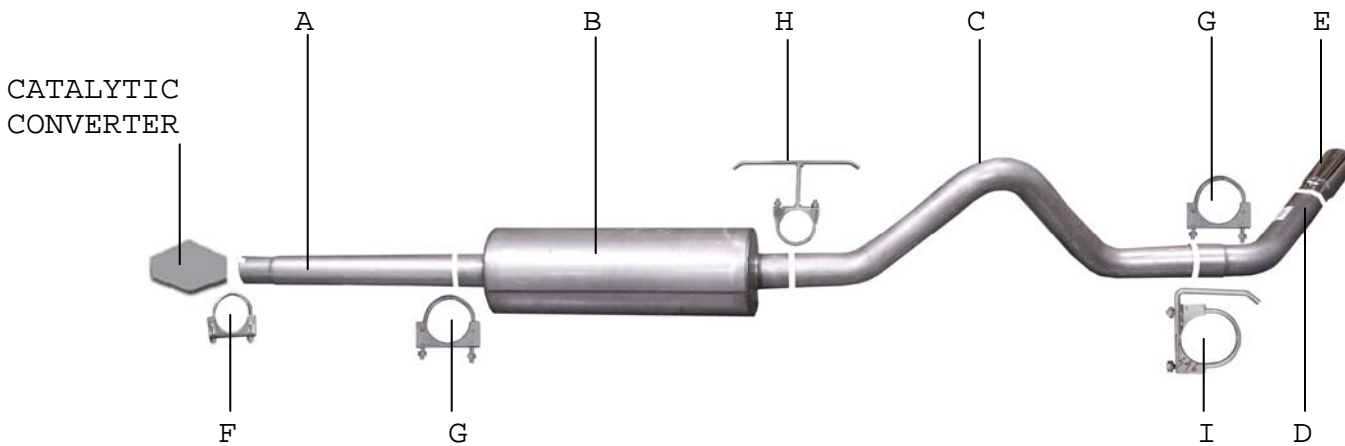

# INSTRUCTION MANUAL

CAT-BACK STAINLESS SINGLE EXHAUST SYSTEM  
 94-95 FORD F350 7.3L TURBO DIESEL TRUCK  
 STANDARD CAB, EXT CAB, CREW CAB

PART # 619501



ITEM	PART #	QUANTITY	DESCRIPTION
A	308-700182S	1	3" HEADPIPE
B	420887	1	SUPERFLOW MUFFLER
C	293-700148S	1	3" OVERAXLE TAILPIPE
D	117-50032RS	1	3" TURNOUT PIPE
E	500360	1	3-1/2" STAINLESS TIP
F	5757	1	2-1/2" CLAMP
G	OHD300	2	3" CLAMP
H	500347	1	REAR MUFFLER HANGER
I	500346	1	TAILPIPE HANGER

Thank you for purchasing our GIBSON EXHAUST SYSTEM for your vehicle. If you need further assistance, please do not hesitate to call our Technical Department at (800) 528-3044, Monday through Friday, 8:00 AM to 5:00 PM 0106

# EXHAUST INSTALLATION

## #319501

WHEN INSTALLING THIS EXHAUST SYSTEM MAKE SURE TO USE ALL THE PROPER SAFETY PRECAUTIONS. USE JACK STANDS WHEN UNDER TRUCK, SET PARKING BRAKE, BLOCK TIRES AND USE SAFETY GLASSES. DO NOT WORK WITH HOT PIPES!

### SUGGESTED TOOLS:

HACKSAW,  $\frac{1}{2}$  WRENCH,  $\frac{1}{2}$  SOCKET, JACKSTAND

1. Remove stock exhaust by cutting 2  $\frac{1}{2}$ " from behind the second O.E. flange, just in front of the stock muffler.
2. Lay out the GIBSON EXHAUST SYSTEM on the floor so it looks like the drawing.
3. Install hangers #H, and #I as provided.
4. Install headpipe #A and clamp using item #F. Do not tighten.
5. Slide muffler #B onto the headpipe. Use a jack stand to support the muffler and connect with clamp #G. Do not tighten.
6. Install the over axle tailpipe #C. Use hanger #H to clamp tailpipe to muffler and attach hanger #I to tailpipe.
7. Slide turnout pipe #D on the tailpipe behind the rear tire. Roll turnout pipe until you have it at the correct angle for your truck and clamp using #G clamp.
8. Install stainless steel tip. Clamp down. To clean stainless tip use a scott brite pad and any stainless steel or aluminum cleaner.
9. When you have everything in place, tighten all bolts and clamp down.

**MAKE SURE YOU HAVE A 1" CLEARANCE ON ALL PIPES FROM ALL RUBBER BRAKE & FUEL LINES, SHOCK BOOTS, TIRES, ETC.**

