

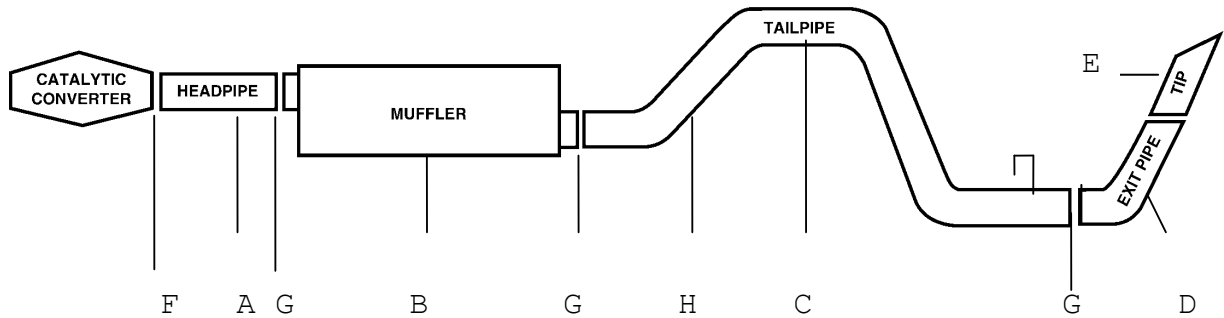

INSTRUCTION MANUAL

CAT-BACK STAINLESS SINGLE EXHAUST

LINCOLN BLACKWOOD 5.4L CREW CAB, SHORT BED 4DOOR PART # 619896



ITEM	PART#	QUANTITY	DESCRIPTION
A	119-25038S	1	3"X 16" STAINLESS HEADPIPE
B	421887	1	STAINLESS SUPERFLOW MUFFLER
C	185-500621S-1	1	3" STAINLESS OVERAXLE TAILPIPE
D	114-500622S	1	3" STAINLESS TURNOUT PIPE
E	500360	1	3-1/2" STAINLESS STEEL TIP
F	5757	1	2-1/2" CLAMP
G	OHD300	3	3" CLAMP
H	4118	1	TAILPIPE T-HANGER

Thank you for purchasing our GIBSON PERFORMANCE EXHAUST SYSTEM for your vehicle. If you need further assistance, please do not hesitate to call our Technical Department at 1-800-528-3044, Monday through Friday, 8:00 am to 5:00 pm.

EXHAUST INSTALLATION

WHEN INSTALLING THIS EXHAUST SYSTEM MAKE SURE YOU USE ALL THE PROPER SAFETY PRECAUTIONS. USE JACK STAND TO SUPPORT THE TRUCK WHILE OFF THE GROUND. SET PARKING BRAKE, BLOCK THE TIRES AND USE SAFETY GLASSES AND GLOVES. DO NOT WORK WITH HOT PIPES!

SUGGESTED TOOLS:

HACKSAW, JACKSTAND, 1/2" WRENCH & SOCKET, 9/16" SOCKET & WRENCH, WD-40



REMOVE YOUR STOCK EXHAUST FROM THE CLAMP LOCATED JUST AFTER YOUR STOCK Y-PIPE. CUT OFF TAILPIPE JUST BEHIND THE MUFFLER USE WD-40 TO AID IN REMOVAL OF HANGER LEAVE RUBBER GROMMETS IN PLACE. NEXT, INSTALL HEADPIPE #A ONTO Y-PIPE USING CLAMP #F TO SECURE, DO NOT TIGHTEN.

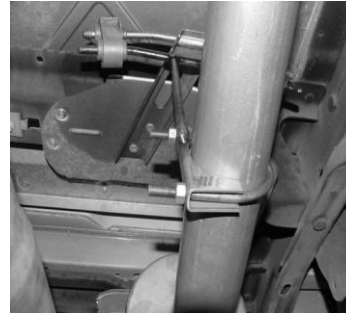

INSTALL T-HANGER # H ONTO OVERAXLE TAILPIPE AND INSERT INTO RUBBER GROMMET. THE HANGER SHOULD BE FACING TOWARDS THE DRIVERSIDE. MAKE SURE YOU HAVE EQUAL SPACE BETWEEN SHOCK AND SPARE TIRE. THE SPARE TIRE MAY NEED TO BE LOOSENED AND PUSH TO THE DRIVER SIDE AND THEN ROTATE TO GAIN CLEARANCE.



INSTALL MUFFLER # B INLET ONTO HEADPIPE 1- 1/2" TO 2" AND ATTACH USING CLAMP #G. INLET OF MUFFLER IS LOOKING INTO THE LOUVERS. MUFFLER OUTLET SHOULD BE ABOUT 6 O'CLOCK. DO NOT TIGHTEN. USE A JACKSTAND TO SUPPORT THE MUFFLER.



INSTALL TURNOUT PIPE #D TO THE OVERAXLE TAILPIPE. ROTATE PIPE SO IT IS AT THE CORRECT ANGLE FOR YOUR VEHICLE. USE CLAMP #G TO ATTACH.



INSTALL OVERAXLE TAILPIPE #C INTO THE MUFFLER NO MORE THAN 1 1/2" TO 2". INSERT WELDED HANGER INTO RUBBER GROMMET. ATTACH USING CLAMP # G.



INSTALL THE STAINLESS STEEL TIP. USE ANY ALUMINUM OR STAINLESS STEEL CLEANER TO POLISH TIP. NOW TIGHTEN ALL CLAMPS, BOLTS AND HANGERS.

MAKE SURE YOU HAVE AT LEAST A 1" CLEARANCE ON ALL BRAKE LINES, FUEL LINES, SHOCKS, TIRES, ETC.