



INSTRUCTION MANUAL

CAT-BACK STAINLESS DUAL SPORT EXHAUST

SILVERADO/SIERRA 1500 TRUCK
 STANDARD CAB, SHORT BED 4.3L, 4.8L, 5.3L 2/4WD
 CLASSIC STANDARD CAB, SHORT BED 4.3L, 4.8L 2/4WD

PART# 65211

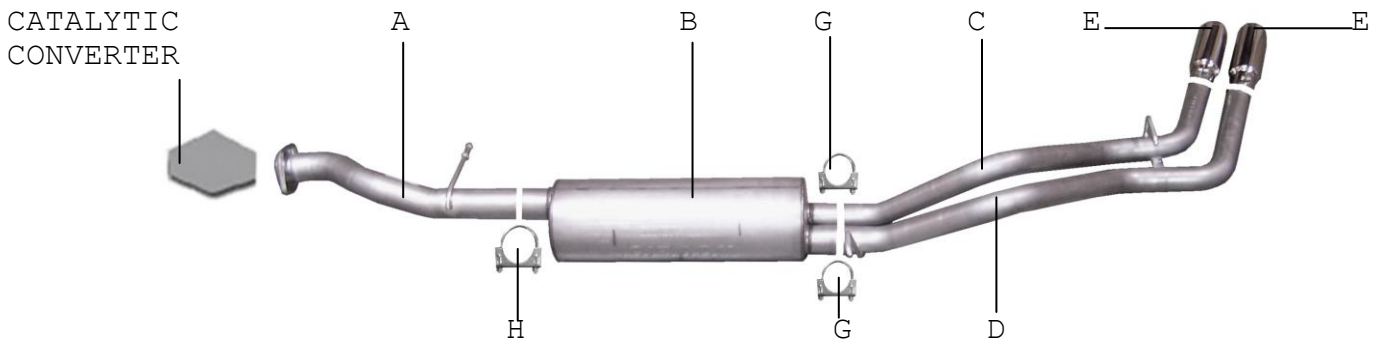

ITEM	PART #	QUANTITY	DESCRIPTION
A	326-700197S	1	3"STAINLESS HEADPIPE W/FLGE #GP-115
B	758250S	1	STAINNESS SUPERFLOW MUFFLER
C	564-700434S	1	2 ½" SS PSGR OVERAXLE TAILPIPE
D	565-700435S	1	2 ½" SS DRIVERSIDE OVERAXLE TAILPIPE
E	500374	2	3 ½" STAINLESS TIPS
F	BO-906	1	BOLT KIT FOR TAILPIPES
G	5757	2	2 ½" CLAMP
H	OHD300	1	3" CLAMP

Thank you for purchasing our GIBSON EXHAUST SYSTEM for your vehicle. If you need further assistance, please do not hesitate to call our Technical Department at 1-800-528-3044, Monday through Friday, 8:00 am to 5:00 PM.

EXHAUST INSTALLATION #65211

When installing this exhaust system make sure to use proper safety precautions. Use jack stands when under the truck, set parking brake, block tires and use safety glasses and gloves.

DO NOT WORK WITH HOT PIPES!

SUGGESTED TOOLS:

1/2", 9/16", 15mm wrench and socket, WD-40, Hacksaw or Sawzall, Jack Stand



Lay out the exhaust on the floor so it looks like the drawing and compare parts with manual. To remove the stock exhaust, remove it from the stock 2-bolt flange located just behind the catalytic converter. Leave all rubber grommets in place. Use WD-40 to aid in removal of exhaust and the hangers. **Do not discard your factory hardware. You will re-use it.**



Install the passenger side over axle tailpipe #D into the muffler. Use clamp #G to secure tailpipe to muffler. Do not tighten. Insert welded hanger into rubber grommet. The spare tire might have to be loosened and pushed towards the drivers side and re-tightened.



Install drivers side over axle tailpipe #C into muffler and secure pipe to muffler using clamp #G. Insert welded hanger into rubber grommet.



Install head pipe # A onto you're existing stock 2-bolt flange. Re-use your stock hardware to secure. Insert welded hanger into rubber grommet. Use a jack stand to support the converter. Do not tighten.



Use bolt kit #F to attach the tailpipes together. Do not tighten. The passenger side tailpipe tab should be on the bottom when bolting together.



Install muffler onto head pipe #A 1-1/2" to 2" with the louvers facing towards the converter. Use a jack stand to support the muffler. Use clamp #H to secure the muffler to the head pipe. Do not tighten. Muffler inlet is looking into the louvers. The muffler outlets should be at the top.



Install the stainless tips. Clamp down. To clean your stainless tips use any stainless cleaner or a Scotch Brite pad. Now go back and tighten all clamps, nuts and bolts. Start from the front and work back.

MAKE SURE YOU HAVE A 1" CLEARANCE ON ALL RUBBER BRAKE LINES, SHOCK BOOTS, TIRE, FUEL LINES, ETC.