



INSTRUCTION MANUAL

CAT-BACK STAINLESS DUAL SPORT EXHAUST

SILVERADO/SIERRA 1500 TRUCK

STANDARD CAB, LONG BED 4.3L, 4.8L, 5.3L 2/4WD

CLASSIC STANDARD CAB, LONG BED 4.3L, 4.8L 2/4WD

PART# 65212

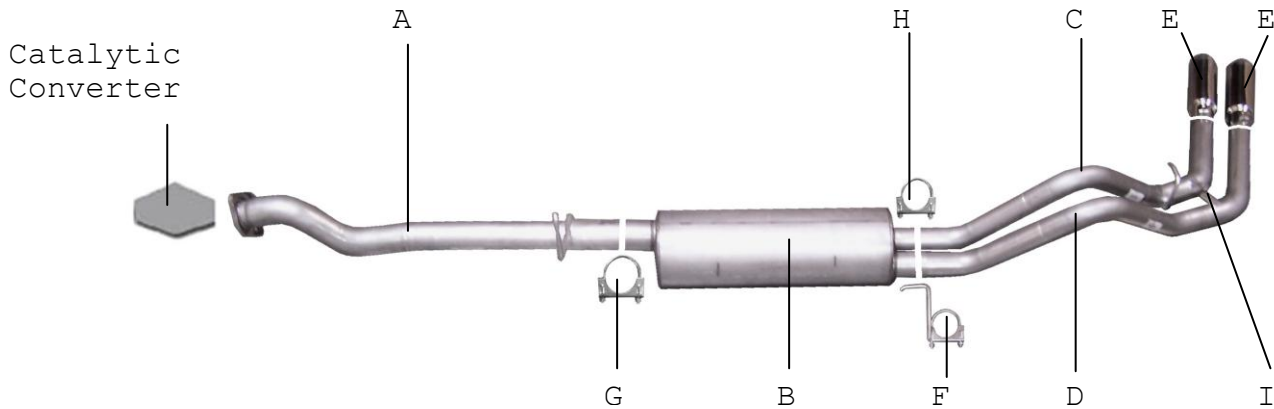

ITEM	PART #	QUANTITY	DESCRIPTION
A	572-700463S	1	3" STAINLESS HEADPIPE W/FLGE#GP-115
B	758250S	1	STAINLESS SUPERFLOW MUFFLER
C	505-700395S	1	2-1/2" STAINLESS OVERAXLE TAILPIPE
D	506-700396S	1	2-1/2" STAINLESS OVERAXLE TAILPIPE
E	500374	2	3-1/2" STAINLESS TIPS
F	4192	1	REAR MUFFLER HANGER
G	OHD300	1	3" CLAMP
H	5757	1	2-1/2" CLAMP
I	BO-906	1	BOLT KIT FOR TAILPIPES
J	4137	1	SPARE TIRE BRACKET

Thank you for purchasing our GIBSON EXHAUST SYSTEM for your vehicle. If you need further assistance, please do not hesitate to call our Technical Department at 1-800-528-3044, Monday through Friday, 8:00 am to 5:00 PM

EXHAUST INSTALLATION #65212

When installing this exhaust system make sure to use proper safety precautions. Use jack stands when under the truck, set parking brake, block tires and use safety glasses and gloves.

DO NOT WORK WITH HOT PIPES!

SUGGESTED TOOLS:

1/2", 9/16", 15mm wrench and socket, WD-40, Hacksaw, Jack Stand



Lay out the exhaust on the floor so it looks like the drawing and compare parts with manual. To remove the stock exhaust un-bolt it from the flange located in front of the muffler. **You will re-use your stock hardware.**

Leave all rubber grommets in place. Use WD-40 to aid in removal of the hangers. Cut your stock tailpipe off just behind the muffler for easier removal.

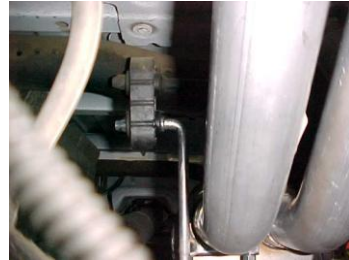

Install the driver side over axle tailpipe # D into the muffler. Use clamp # F to secure tailpipe to muffler. Do not tighten



Install head pipe # A onto you're existing stock flange re-using the factory hardware. Do not tighten. Insert welded hanger into rubber grommet.



Install passenger side over axle tailpipe # C into muffler and attach using clamp # H. Use bolt kit # I to attach the tailpipes together. Insert hanger into rubber grommet. Do not tighten. **YOU MAY NEED TO LOOSEN YOUR SPARE TIRE & PUSH TOWARDS DRIVER SIDE & RE-TIGHTEN.**



Install muffler #B onto head pipe # A 1-1/2" to 2" with the louvers facing towards the converter. Use a jack stand to support the muffler. Use clamp # G to secure the muffler to the head pipe. Do not tighten.



Install the stainless tips. Clamp down. To clean your stainless tips use any stainless cleaner or a Scotch Brite pad. Now go back and tighten all clamps, nuts and bolts. Start from the front and work back.

MAKE SURE YOU HAVE A 1" CLEARANCE ON ALL RUBBER BRAKE LINES, SHOCK BOOTS, TIRE, FUEL LINES, ETC.