



INSTRUCTION MANUAL

CAT-BACK STAINLESS DUAL SPORT EXHAUST

02-06 ESCALADE 5.3L 2/4WD

00-06 TAHOE, DENALI, YUKON 4.8L-5.3L 2/4WD

PART# 65601

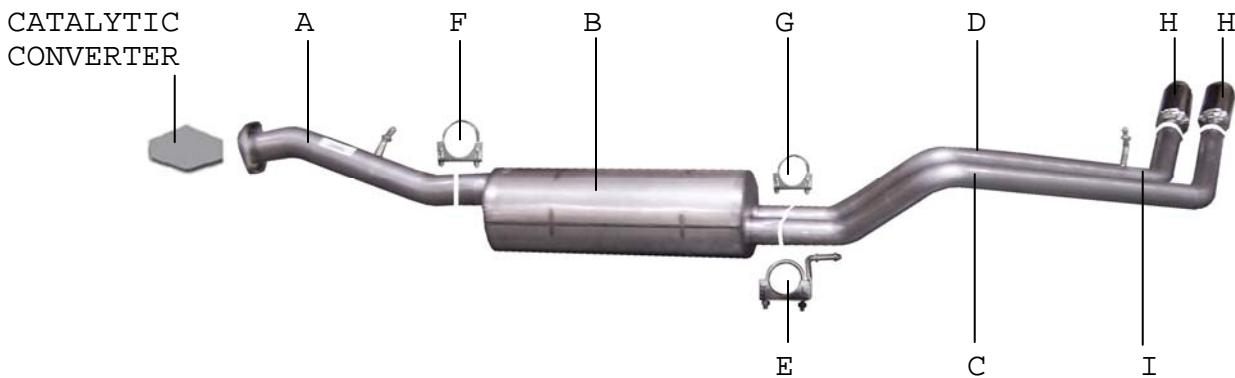

ITEM	PART #	QUANTITY	DESCRIPTION
A	818-700557S	1	3" STAINLESS HEADPIPE WITH FLANGE# GP-115
B	758300S	1	STAINLESS SUPERFLOW MUFFLER
C	825-700559S	1	2-1/4" SS DRIVERSIDE TAILPIPE
D	826-700560S	1	2-1/4" SS PASSENGERSIDE TAILPIPE
E	4324	1	REAR MUFFLER HANGER
F	OHD300	1	3" CLAMP
G	5756	1	2-1/4" CLAMP
H	500395	2	3-1/2" STAINLESS TIPS
I	BO-906	1	BOLT KIT FOR TAILPIPE

Thank you for purchasing our GIBSON EXHAUST SYSTEM for your vehicle. If you need further assistance, please do not hesitate to call our Technical Department at 1-800-528-3044, Monday through Friday, 8:00 am to 5:00 PM. 1205

EXHAUST INSTALLATION PART # 65601

WHEN INSTALLING THIS EXHAUST SYSTEM MAKE SURE TO USE ALL THE PROPER SAFETY PRECAUTIONS. USE JACK STANDS WHEN UNDER TRUCK SET PARKING BRAKE, BLOCK TIRES AND USE SAFETY GLASSES. DO NOT WORK WITH HOT PIPES! USE A JACK STAND UNDER YOUR CATALYTIC CONVERTER TO SUPPORT THE SYSTEM DURING YOUR INSTALL.

SUGGESTED TOOLS:

9/16" SOCKET, 1/2" WRENCH, 1/2" SOCKET, 15mm SOCKET, JACK STAND, WD-40

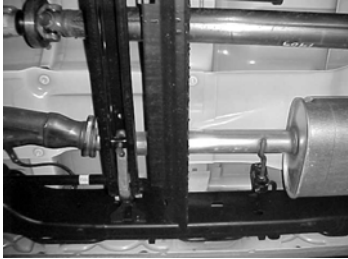

LAY OUT THE GIBSON EXHAUST ON THE FLOOR AND COMPARE PART #'S TO THE DRAWING. TO REMOVE STOCK EXHAUST, REMOVE IT FROM THE 2-BOLT FLANGE LOCATED IN FRONT OF THE MUFFLER. DO NOT DISGUARD FACTORY HARDWARE YOU WILL RE-USE IT. LEAVE ALL RUBBER GROMMETS IN PLACE. USE WD-40 TO AID IN REMOVAL OF EXHAUST AND THE RUBBER GROMMETS.



INSTALL PASSENGER TAILPIPE #D INTO MUFFLER OUTLET NO MORE THAN 1-1/2" TO 2". INSERT THE WELDED HANGER INTO THE RUBBER GROMMET. USE CLAMP # G TO ATTACH TO MUFFLER OUTLET. DO NOT TIGHTEN



INSTALL HEAD PIPE # A ONTO YOUR EXISTING STOCK FRONT PIPE. INSERT WELDED HANGER INTO RUBBER GROMMET. YOU WILL BE USING THE FACTORY HARDWARE.

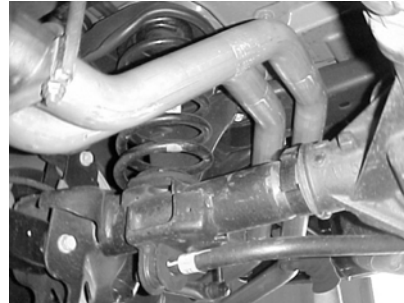

INSTALL DRIVERSIDE TAILPIPE # C INTO OUTLET OF MUFFLER, 1-1/2" TO 2". REAR MUFFLER HANGER #E WILL BE USED TO SECURE PIPE TO MUFFLER. DO NOT TIGHTEN.



INSTALL MUFFLER # B ONTO HEAD PIPE 1-1/2"-2" WITH THE LOUVERS FACING TOWARDS THE CONVERTER. USE A JACK STAND TO SUPPORT THE MUFFLER. USE CLAMP # F TO SECURE THE MUFFLER TO THE HEADPIPE. DO NOT TIGHTEN.



ATTACH BOTH TAILPIES USING BOLT KIT # I. THE PASSENGER SIDE MOUNTING BRACKET WILL BE POSITIONED UNDERNEATH THE DRIVERSIDE. NOW GO BACK AND TIGHTEN ALL CLAMPS, HANGERS AND BOLTS.



INSTALL REAR MUFFLER HANGER # E ONTO DRIVER SIDE OUTLET OF THE MUFFLER AND INSERT THE WELDED HANGER INTO RUBBER GROMMET.



NEXT, INSTALL YOUR STAINLESS STEEL TIPS . TO CLEAN YOUR TIPS USE A SCOTCH BRITE PAD AND ANY STAINLESS STEEL OR ALUMINUM CLEANER.

"MAKE SURE HAVE A MINIMUM OF A 1" ON ALL PIPES FROM ALL RUBBER BRAKE LINES, TIRES, SHOCKS, FUEL LINES, ETC.