

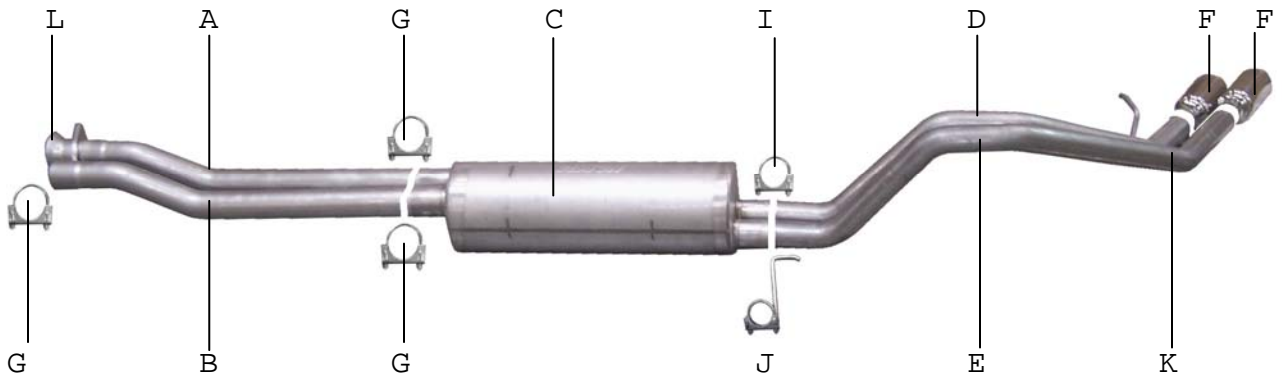

# INSTRUCTION MANUAL

## CAT-BACK STAINLESS DUAL SPORT EXHAUST 01-06 YUKON, DENALI XL 6.0L V8, AWD, 4DR PART# 65605



ITEM	PART #	QUANTITY	DESCRIPTION
A	643-700508S	1	2-1/2" PASSENGER STAINLESS HEADPIPE W/ FLANGE GP-105
B	644-700509S	1	2-1/2" STAINLESS HEADPIPE
C	788701S	1	STAINLESS SUPERFLOW MUFFLER
D	645-700510S	1	2-1/4" STAINLESS PASSENGER SIDE TAILPIPE W/HANGER
E	646-700511S	1	2-1/4" STAINLESS DRIVER SIDE TAILPIPE
F	500395	2	3 1/2" STAINLESS TIPS
G	5757	3	2-1/2" CLAMP
I	5756	1	2 1/4" CLAMP
J	4226	1	REAR MUFFLER HANGER
K	BO-906	1	BOLT KIT FOR TAILPIPES
L	BO-1028	1	BOLT KIT FOR HEADPIPE FLANGE

**MUST REMOVE SPARE TIRE IF LARGER THAN 16"**

Thank you for purchasing our GIBSON EXHAUST SYSTEM for your vehicle.  
If you need further assistance, please do not hesitate to call our  
Technical Department at 800-528-3044, Monday through Friday,  
8:00 am to 5:00 PM. 0706

# EXHAUST INSTALLATION #65605

WHEN INSTALLING THIS EXHAUST SYSTEM MAKE SURE TO USE ALL THE PROPER SAFETY PRECAUTIONS. USE JACK STANDS WHEN UNDER TRUCK, SET PARKING BRAKE, BLOCK TIRES AND USE SAFETY GLASSES. **DO NOT WORK WITH HOT PIPES!**

## SUGGESTED TOOLS:

9/16" SOCKET, 1/2" WRENCH, 1/2" SOCKET, 15mm SOCKET, JACK STAND, HACKSAW, WD-40

LAY OUT THE GIBSON EXHAUST AND COMPARE PART NUMBERS WITH THE MANUAL.



TO REMOVE STOCK EXHAUST CUT YOUR STOCK TAILPIPE OFF, REMOVE HANGERS FROM RUBBER GROMMETS, USE WD-40 TO HELP WITH REMOVAL. NOW UN-BOLT YOUR FACTORY EXHAUST AT THE FLANGE LOCATED JUST AFTER YOUR Y-PIPE.



INSTALL PASSENGER SIDE OVERAXLE TAILPIPE #D INTO MUFFLER 1-1/2" TO 2" . INSERT WELDED HANGER INTO RUBBER GROMMET. USE CLAMP #I TO SECURE PIPE TO MUFFLER. DO NOT TIGHTEN.



BOLT HEADPIPE # A ONTO STOCK HEADPIPE AND ATTACH TO FLANGE WITH BOLT KIT #L. INSERT WELDED HANGER INTO RUBBER GROMMET. DO NOT TIGHTEN. INSTALL HEADPIPE # B, SLIP IT ONTO THE STOCK HEADPIPE USING CLAMP # G TO SECURE THE HEADPIPE TO THE STOCK PIPE. DO NOT TIGHTEN.



INSTALL DRIVERS SIDE OVERAXLE TAILPIPE #E INTO MUFFLER 1-1/2" TO 2" . ATTACH TO MUFFLER WITH HANGER #J. USE BOLT KIT #K TO ATTACH BOTH TAILPIPES TOGETHER. DRIVERS SIDE TAB WILL BE ON THE BOTTOM.



NEXT INSTALL MUFFLER #C. SLIDE IT ONTO HEADPIPE 1-1/2" TO 2" . INLET OF MUFFLER SHOULD FACE TOWARDS THE MOTOR. ATTACH TO HEADPIPE WITH CLAMP #G. INSTALL REAR MUFFLER HANGER #J INTO RUBBER GROMMET LOCATED JUST ABOVE THE DRIVERS SIDE OUTLET OF THE MUFFLER. SLIDE CLAMP ONTO MUFFLER OUTLET. INLET OF MUFFLER IS



INSTALL YOUR STAINLESS STEEL TIPS. TO CLEAN TIPS USE ANY STAINLESS OR ALUMINUM CLEANER. NOW GO BACK AND TIGHTEN ALL NUTS, BOLTS AND CLAMPS STARTING FROM THE FRONT AND WORKING BACK.



**"MAKE SURE HAVE A MINIMUM OF A 1" ON ALL PIPES FROM ALL RUBBER BRAKE LINES, TIRES, SHOCKS, FUEL LINES, ETC."**