

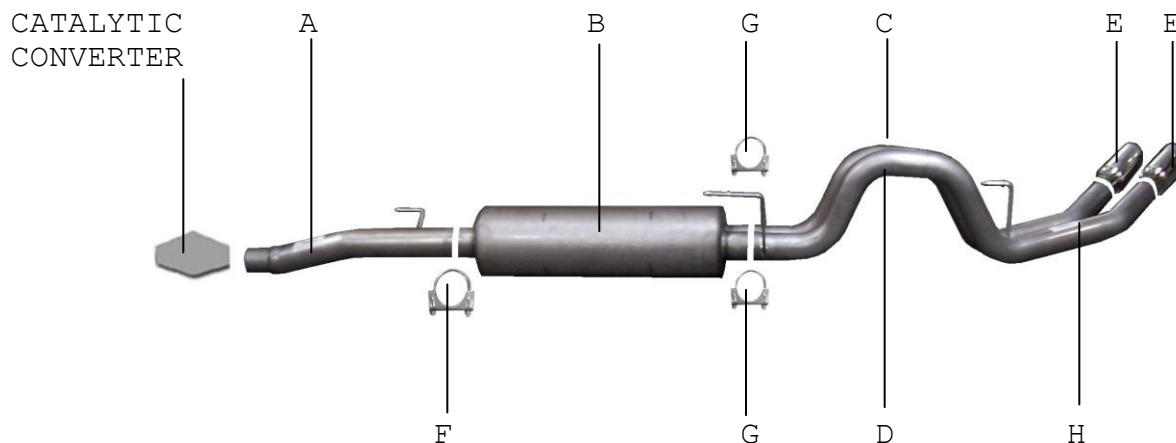

INSTRUCTION MANUAL
CAT-BACK DUAL SPORT EXHAUST
FORD F150 TRUCK 4.6L-5.4L 2/4WD
SUPERCREW, SHORT BED
SUPERCAB, SHORT BED
SUPERCAB, LONG BED
PART # 9203



ITEM	PART#	QUANTITY	DESCRIPTION
A	700643	1	3" HEADPIPE W/HANGER
B	789800	1	SUPERFLOW MUFFLER
C	700641	1	2.5" PASSENGER SIDE TAILPIPE
D	700642	1	2.5" DRIVER SIDE TAILPIPE
E	500374	2	3.5" STAINLESS TIPS
F	OHD300	1	3" CLAMP
G	5757	2	2.5" CLAMP
H	BO-906	1	BOLT KIT FOR TAILPIPES

MFG. BEFORE AUG. 2004
WILL FIT WITH AN 18" SPARE TIRE

Thank you for purchasing our GIBSON PERFORMANCE EXHAUST SYSTEM for your vehicle. If you need further assistance, please do not hesitate to call our Technical department at 1-800-528-3044 Monday through Friday, 8:00 am to 5:00 pm.

EXHAUST INSTALLATION #9203

WHEN INSTALLING THIS EXHAUST SYSTEM MAKE SURE YOU USE ALL THE PROPER SAFETY PRECAUTIONS. USE JACK STAND TO SUPPORT THE TRUCK WHILE OFF THE GROUND. SET PARKING BRAKE, BLOCK THE TIRES AND USE SAFETY GLASSES AND GLOVES. DO NOT WORK WITH HOT PIPES!

SUGGESTED TOOLS:

HACKSAW, JACKSTAND, 1/2" WRENCH & SOCKET, 9/16" SOCKET & WRENCH, WD-40, MEASURING TAPE

TO REMOVE STOCK EXHAUST SEE BELOW FOR PROPER VEHICLE APPLICATION.



TO REMOVE YOUR STOCK EXHAUST, REMOVE IT FROM THE CLAMP LOCATED JUST IN FRONT OF THE MUFFLER REMOVE HANGERS FROM RUBBER GROMMETS BY PULLING EXHAUST TOWARDS THE REAR OF THE VEHICLE, USE WD-40 TO AID IN REMOVAL, LEAVE GROMMETS IN PLACE.



INSTALL DRIVERS SIDE TAILPIPE # D INTO MUFFLER 1 1/2" TO 2". INSERT HANGER INTO RUBBER GROMMET, USE CLAMP # G TO SECURE PIPE TO MUFFLER. DO NOT TIGHTEN. THE TAB ON THIS PIPE SHOULD GO ON TOP OF PASSENGER SIDE PIPE USE BOLT KIT # J TO SECURE TOGETHER.



INSTALL HEADPIPE # A INTO STOCK PIPE. THE END OF THE PIPE SHOULD BE AT THE 9 O'CLOCK POSITION, ATTACH WITH FACTORY CLAMP TO HEADPIPE. DO NOT TIGHTEN.



INSTALL MUFFLER # B ONTO HEADPIPE 1 1/2" TO 2". USE CLAMP # F TO SECURE MUFFLER TO HEADPIPE. DO NOT TIGHTEN. USE A JACK STAND TO HOLD UP THE MUFFLER. OUTLETS SHOULD BE LEVEL.



INSTALL YOUR STAINLESS TIPS TO YOUR DESIRED LOOK. NOW GO BACK AND TIGHTEN ALL CLAMPS FROM THE FRONT WORKING YOUR WAY BACK.



INSTALL PASS. SIDE TAILPIPE # C INTO MUFFLER 1 1/2" TO 2". INSERT HANGER INTO RUBBER GROMMET, USE CLAMP # G TO SECURE PIPE TO MUFFLER. DO NOT TIGHTEN. YOU MAY NEED TO LOOSEN AND PUSH OVER TOWARDS THE DRIVERS SIDE AND RE-TIGHTEN.



MAKE SURE YOU AT LEAST A 1" CLEARANCE ON ALL BRAKE LINES, FUEL LINES, SHOCKS, TIRES, ETC.