



INSTRUCTION MANUAL

CAT-BACK DUAL SPORT TRUCK

FORD F150/F250 TRUCK 4.2L-4.6L-5.4L 2/4WD
STANDARD & EXTENDED CAB - SHORT & LONG BED

PART# 9700

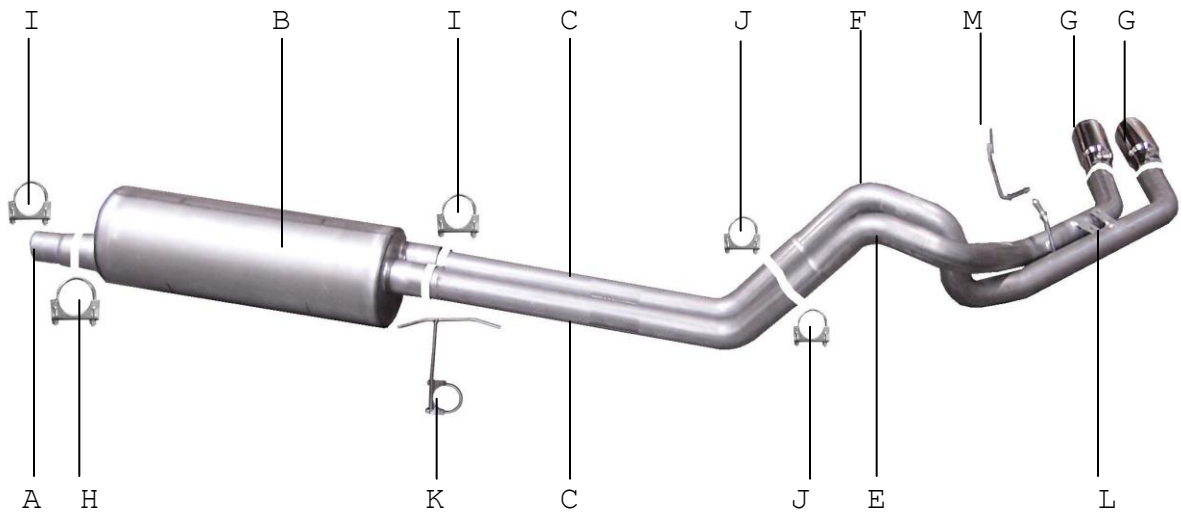

ITEM	PART #	QUANTITY	DESCRIPTION
A	30004	1	HEADPIPE
B	758250	1	SUPERFLOW MUFFLER
C	700232	2	2 ¼" FRONT PIPE
E	700173-2	1	2 ¼" DRIVER OVERAXLE TAILPIPE
F	700174-2	1	2 ¼" PASSENGER OVERAXLE TAILPIPE
G	500370	2	3" STAINLESS TIP
H	OHD300	1	3" CLAMP
I	5757	2	2 ½" CLAMP
J	5756	2	2- ¼" CLAMP
K	40087	1	REAR MUFFLER HANGER
L	BO-906	1	BOLT KIT FOR TAILPIPE
M	40088	1	REAR FRAME HANGER TO TAILPIPE

WILL NOT FIT HEAVY DUTY TRUCK 4WD'S MAY NEED TO REMOVE SPARE TIRE.

Thank you for purchasing our GIBSON EXHAUST SYSTEM for your vehicle. If you need further assistance, please do not hesitate to call our Technical Department at (800) 528-3044, Monday through Friday, 8:00 am to 5:00 pm.

EXHAUST INSTALLATION

PART #9700

WHEN INSTALLING THIS EXHAUST SYSTEM, MAKE SURE TO USE PROPER SAFETY PRECAUTIONS. USE JACK STAND WHEN UNDER TRUCK, SET PARKING BRAKE, BLOCK TIRES, AND USE SAFETY GLASSES AND GLOVES. DO NOT WORK WITH HOT PIPES!

SUGGESTED TOOLS:

9/16" SOCKET, 9/16" WRENCH, 1/2" SOCKET, 1/2" WRENCH, HACKSAW, JACKSTAND

1. Lay out the GIBSON EXHAUST SYSTEM on the floor so it looks like the drawing.(Note: Drawing is not exact but for placement of parts only.)
2. Cut the stock exhaust 3" in front of the nipple located on the stock headpipe.
3. Remove factory exhaust system leaving all rubber grommets in place
4. Install #K hanger into factory rubber grommets. (Note: the vertical rod on hanger is on driver's side.)
5. Install #A head pipe onto factory pipe using #I clamp (DO NOT TIGHTEN.)
6. Install muffler onto headpipe using #H clamp . #K hanger supports drivers side muffler outlet. (Note: muffler in let is at 12 O'clock.)
7. Install both driver's side and passenger side #C pipes into muffler using #I clamp on passenger side, #K on driver side. (DO NOT TIGHTEN.)
8. Install #E & #F overaxle pipes onto #C pipes using #J clamps. (DO NOT TIGHTEN.)
9. Install hanger #M on passenger side of frame using factory rubber hanger left over from the removal of the stock kit. Install hanger #M measuring from rear frame 22 1/2 " forward to slotted hole, using 3/8" bolt, nut and washer.
10. Installs stainless tips. To clean stainless steel tip use a scotch brite pad and any stainless or aluminum cleaner.
11. When you have everything in place, firmly tighten all bolts and clamp down securely
(Note: Starting from the rear and working forward will help keep the pipes level and straight.)

SPECIAL NOTES:

- MAKE SURE YOU HAVE A 1" CLEARANCE ON ALL PIPES FROM ALL RUBBER BRAKE LINES, SHOCK BOOTS, TIRES, ETC
- SOME STOCK AND OVERSIZED SPARE TIRES MAY HAVE TO BE REMOVED