



INSTRUCTION MANUAL

CAT-BACK DUAL SPORT TRUCK EXHAUST

FORD EXCURSION 5.4L-6.8L 2WD

PART # 9900

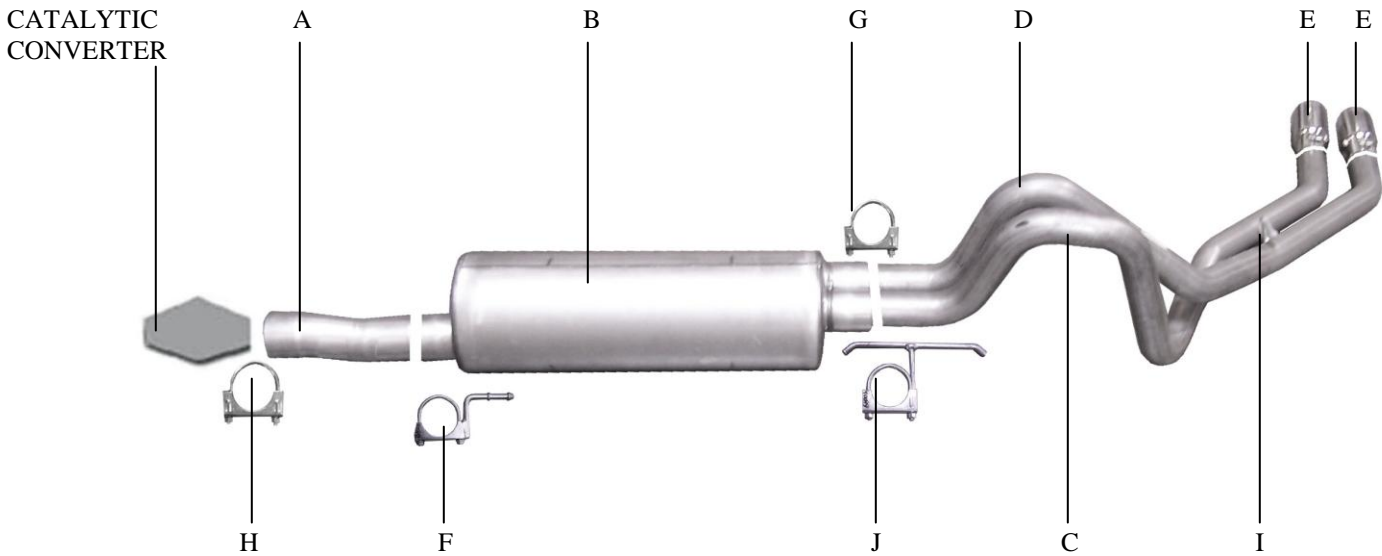

ITEM	PART#	QTY	DESCRIPTION
A	500455	1	3" X 9" HEADPIPE
B	758250	1	SUPERFLOW MUFFLER
C	700259	1	2 ¼" DRIVER OVERAXLE TAILPIPE
D	700260	1	2 ¼" PASSENGER OVERAXLE TAILPIPE
E	500370	2	3" STAINLESS TIP
F	40098	1	FRONT MUFFLER HANGER
G	5757	1	2 ½" CLAMP
H	OHD300	1	3" CLAMPS
I	BO-906	1	BOLT KIT FOR TAILPIPE
J	40099	1	REAR MUFFLER HANGER

Thank you for purchasing our GIBSON EXHAUST SYSTEM for your vehicle. If you need any further assistance, please do not hesitate to call our Technical Department at 800-528-3044, Monday-Friday 8:00AM-5:00PM.PST

INSTALLATION INSTRUCTIONS

PART #9900

WHEN INSTALLING THIS EXHAUST SYSTEM, MAKE SURE TO USE THE PROPER SAFETY PRECAUTIONS. USE JACK STAND WHEN UNDER TRUCK, SET PARKING BRAKE, BLOCK TIRES, AND USE SAFETY GLASSES AND GLOVES. DO NOT WORK WITH HOT PIPES!

SUGGESTED TOOLS:

15mm SOCKET, 9/16" SOCKET, 1/2" SOCKET, 1/2" WRENCH, JACK STAND, HACKSAW

LAY OUT THE GIBSON EXHAUST ON THE FLOOR SO IT LOOKS LIKE THE DRAWING AND COMPARE PART NUMBERS. (NOTE: DRAWING IS ONLY FOR PLACEMENT OF PARTS)



1. UN-BOLT THE FACTORY EXHAUST IN FRONT OF THE FACTORY MUFFLER. FOR EASIER INSTALLATION CUT THE FACTORY TAILPIPE BEHIND THE MUFFLER AND USE A HACKSAW TO REMOVE THE MUFFLER AND HEADPIPE. NEXT REMOVE THE FACTORY REAR HANGER UNDERNEATH THE BUMPER. LEAVE ALL OTHER FACTORY RUBBER GROMMETS IN PLACE.

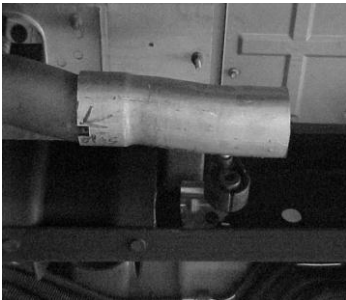

2. SLIP HEADPIPE #A ONTO THE FACTORY HEADPIPE. USE CLAMP #H TO ATTACH IT. DO NOT TIGHTEN.



3. SLIP THE MUFFLER #B ONTO HEADPIPE #A NO LESS THEN 1- 1/2" AND NO MORE THEN 2". THE MUFFLER OUTLETS WILL BE LEVEL AT THE 12 O'CLOCK POSITION. THEN INSTALL HANGER #F ON THE INLET OF THE MUFFLER AND INSERT WELDED HANGER INTO RUBBER GROMMET. DO NOT TIGHTEN.

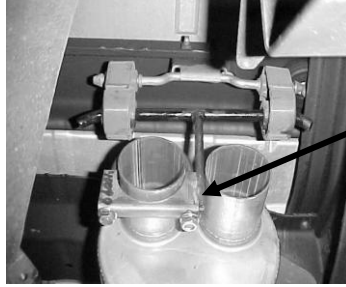

4. INSTALL HANGER #J ON THE DRIVER SIDE OUTLET OF MUFFLER WITH THE VERTICAL ROD IN BETWEEN THE TWO OUTLETS. DO NOT TIGHTEN



5. SLIP OVERAXLE PIPE #C ON THE PASSENGER SIDE OUTLET OF THE MUFFLER NO LESS THEN 1 1/2" AND NO MORE THEN 2". ATTACH TO MUFFLER USING CLAMP #G. DO NOT TIGHTEN. SLIP OVERAXLE PIPE #D INTO THE DRIVER SIDE MUFFLER OUTLET AND ATTACH WITH HANGER #J. NOTE: DRIVER SIDE OVERAXLE TAILPIPE ROUTES UNDER PASSENGER SIDE OVERAXLE PIPE, ENDING UP IN FRONT OF PASSENGER SIDE OVERAXLE. ATTACH BOLT ASSEMBLY #I. DO NOT TIGHTEN



6. INSTALL YOUR STAINLESS STEEL TIPS TO YOUR DESIRED LOOK. USE ANY ALUMINUM OR STAINLESS STEEL CLEANER TO POLISH YOUR TIPS. NOW TIGHTEN ALL CLAMPS AND HANGERS.

MAKE SURE YOU HAVE A 1" CLEARANCE ON ALL BRAKE LINES, TIRES, SHOCK BOOTS, FUEL LINES, ETC...