



INTAKE SYSTEMS FOR VEHICLES LISTED ARE 50 STATE LEGAL. SEE KNFILTERS.COM FOR CARB STATUS ON EACH PART FOR A SPECIFIC VEHICLE.

INSTALLATION INSTRUCTIONS

57-1003
BMW
2001-05 M3
L6-3.2L

TOOLS NEEDED:

- Ratchet
- Extension
- 10mm Socket
- 13mm Socket
- Flat Blade Screwdriver
- 4mm Allen Wrench

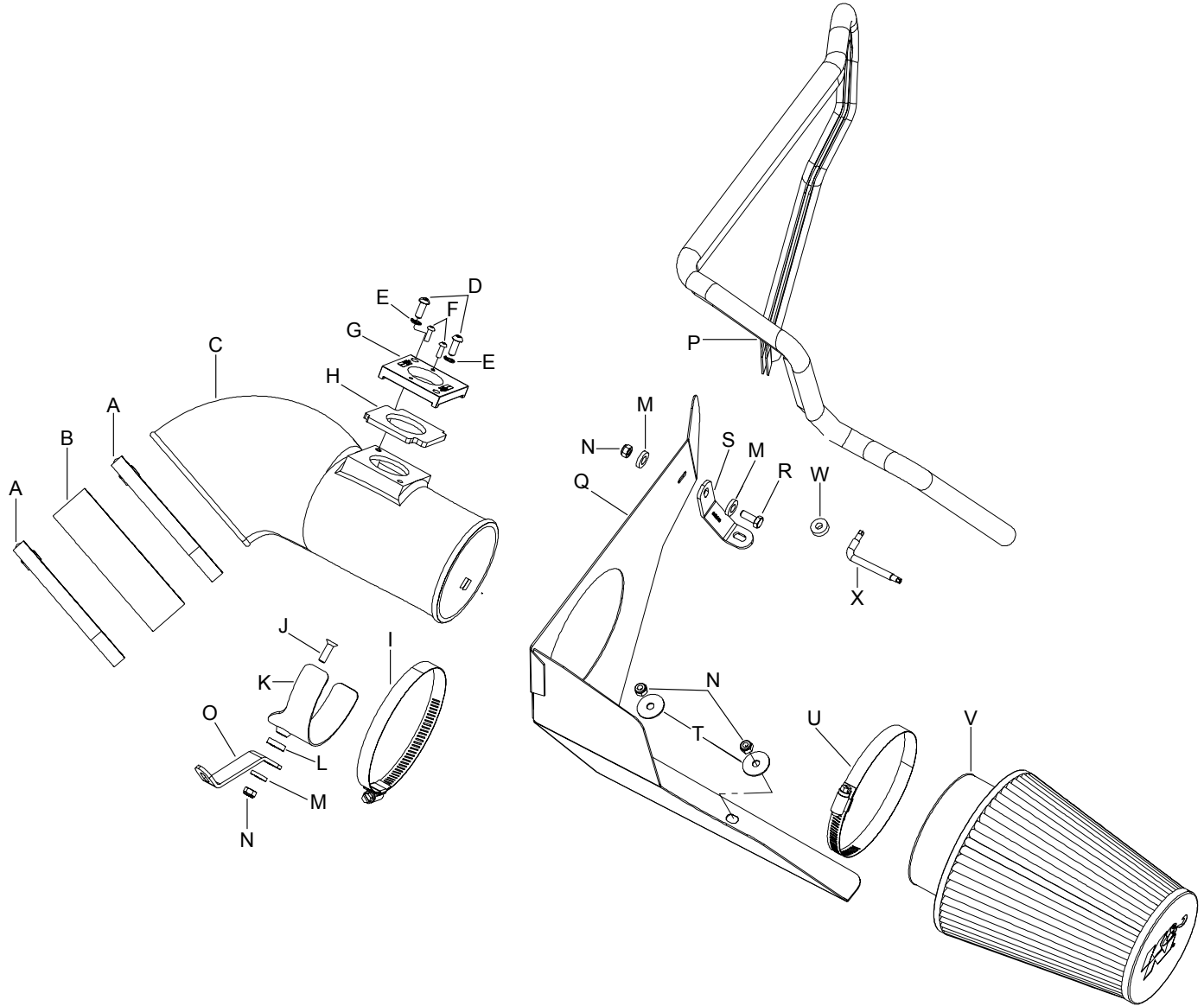

PARTS LIST:

Description	Qty.	Part #	Description	Qty.	Part #	Description	Qty.	Part #
A HOSE CLAMP; #80	2	08685	I HOSE CLAMP; #60	1	08628	Q HEAT SHIELD	1	07499
B HOSE; 5-3/16"ID X 1.5"L	1	08612	J BOLT; M6-1.00 X 20MM	1	08376	R BOLT; M6-1.00 X 16MM	1	07703
C INTAKE TUBE; EN	1	087154A	K BRACKET; SADDLE	1	078855	S BRACKET; "U" SM	1	010090
D BOLT; M6-1.00 X 25MM	2	07729	L WASHER; CONCIAL	1	08180	T WASHER; 1"D X 1/4" HOLE	2	08160
E WASHER; 1/4" LOCK	2	08198	M WASHER; 1/4"ID X 5/8"OD	3	08275	U HOSE CLAMP; #72	1	08671
F SCREW; M4-.7 X 12	2	07726	N NUT; MM NYLOCK	4	07553	V AIR FILTER	1	RU-1032
G ADAPTER; #440	1	21517	O BRACKET; "Z"	1	010091	W WASHER; 1"OD X .37"ID	1	08281
H GASKET; 3/16" PORON	1	09074	P EDGE TRIM; 50"L	1	102481	X WRENCH; TORX T20	1	69801

NOTE: FAILURE TO FOLLOW INSTALLATION INSTRUCTIONS AND NOT USING THE PROVIDED HARDWARE MAY DAMAGE THE INTAKE TUBE, THROTTLE BODY AND ENGINE.

TO START:

1. Turn off the ignition and disconnect the negative battery cable.

NOTE: Disconnecting the negative battery cable erases pre-programmed electronic memories. Write down all memory settings before disconnecting the negative battery cable. Some radios will require an anti-theft code to be entered after the battery is reconnected. The anti-theft code is typically supplied with your owner's manual. In the event your vehicles' anti-theft code cannot be recovered, contact an authorized dealership to obtain your vehicles anti-theft code.



2. Remove the four 13mm nuts that secure the strut tower brace to the vehicle, then remove the brace from the vehicle.



3. Squeeze the two locking tabs together, then remove the mass air electrical connection as shown.



4. Loosen the hose clamp at the intake plenum and release the two clips that secure the air box lid to the vehicle. Remove the upper air box and intake tube as shown.



5. Remove the cover to the head light module to gain access to the air box bolts and module nut. Remove the bolts and nut.



6. Lift the head light module and place out of the way on the core support to gain access to the lower air box for removal.



7. Remove the lower air box assembly as shown.
NOTE: K&N Engineering, Inc., recommends that customers do not discard factory air intake.



8. Lift up on lower air box mount and then remove from vehicle.



9. Remove the nut that secures the dip stick to the intake plenum.



10. Remove the intake o-ring from the plenum as shown.



11. Install the edge trim onto the heat shield as shown.
NOTE: Trim if necessary.



12. Install the heat shield into the vehicle. Make sure the lower air box mounting studs protrude through the heat shield mounting holes.



13. Secure the heat shield to the vehicle with the provided hardware. Secure bracket (010090) to the heat shield and inner fender.
NOTE: Use bolt that was removed in step 5 to secure the bracket to the inner fender.



14. Re-install the head light module with the original hardware that was removed in step 5.
NOTE: Install provided spacer under front mount as shown, then re-install module cover.



15. Install the silicone hose (08612) onto the intake plenum as shown using the provided hose clamps.



16. Remove the two screws that secure the mass air sensor to the air box with the provided Torx wrench, then remove the mass air sensor.



17. Install the provided gasket onto the mass air adapter as shown, sticky side down.

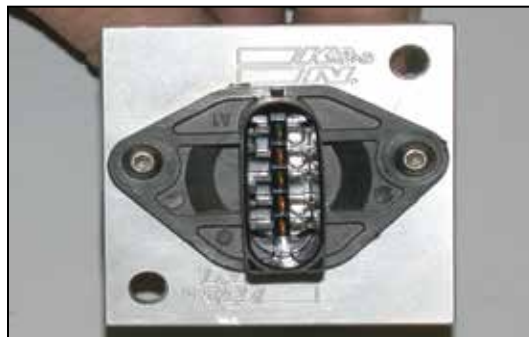

18. Install the mass air sensor into the mass air adapter as shown, secure with the provided hardware.

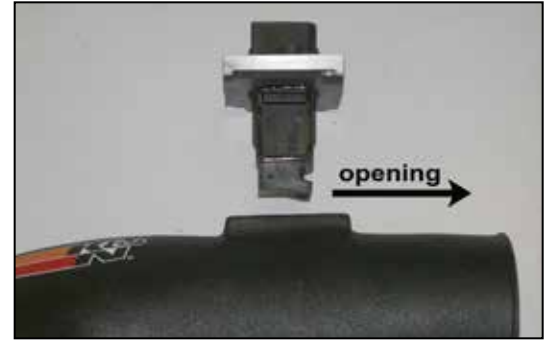

19. Install the mass air sensor assembly into the K&N® intake tube.
NOTE: Make sure the open end of the mass air sensor faces toward the filter end of the tube.



20. Secure the mass air sensor assembly into the K&N® intake tube with the provided hardware as shown.



21. Attach the K&N® intake tube to the plenum with the provided hose clamp.
NOTE: Do not tighten hose clamp completely.



22. Assemble the saddle clamp to the tube bracket (010091) with the provided hardware as shown.



23. Attach the saddle bracket assembly to the intake plenum with the nut removed in step 9, then attach the saddle bracket to the intake tube with the provided hose clamp.



24. Install the K&N® air filter onto the K&N® intake tube and secure with the provided hose clamp.



25. Reconnect the mass air sensor electrical connection as shown.



26. Re-install the strut tower brace that was removed in step 2.



27. Reconnect the vehicle's negative battery cable. Double check to make sure everything is tight and properly positioned before starting the vehicle.

28. The C.A.R.B. exemption sticker, (attached), must be visible under the hood so that an emissions inspector can see it when the vehicle is required to be tested for emissions. California requires testing every two years, other states may vary.

29. It will be necessary for all K&N® high flow intake systems to be checked periodically for realignment, clearance and tightening of all connections. Failure to follow the above instructions or proper maintenance may void warranty.

ROAD TESTING:

1. Start the engine with the transmission in neutral or park, and the parking brake engaged. Listen for air leaks or odd noises. For air leaks secure hoses and connections. For odd noises, find cause and repair before proceeding. This kit will function identically to the factory system except for being louder and much more responsive.

2. Test drive the vehicle. Listen for odd noises or rattles and fix as necessary.

3. If road test is fine, you can now enjoy the added power and performance from your kit.

4. K&N Engineering, Inc., requires cleaning the intake system's air filter element every 100,000 miles. When used in dusty or off-road environments, our filters will require cleaning more often. We recommend that you visually inspect your filter once every 25,000 miles to determine if the screen is still visible. When the screen is no longer visible some place on the filter element, it is time to clean it. To clean and re-oil, purchase our filter Recharger® service kit, part number 99-5050 or 99-5000 and follow the easy instructions.

INTAKE SYSTEMS FOR VEHICLES LISTED ARE 50 STATE LEGAL. SEE KNFILTERS.COM FOR CARB STATUS ON EACH PART FOR A SPECIFIC VEHICLE.