

**KIT FEATURES**

- ▶ ISO-DIN head unit provisions
- ▶ Incorporates factory climate controls into installation
- ▶ Passenger Air Bag On/Off Light Incorporated

**KIT COMPONENTS**

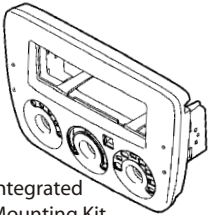

Integrated Mounting Kit

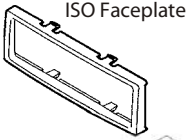

ISO Faceplate

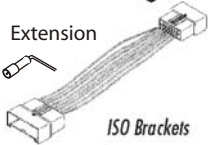

Extension

ISO Brackets

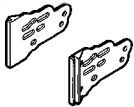

(2) #8 x 3/8" Phillips Pan-head Screws

**TOOLS REQUIRED**



86-5618 - Head unit removal keys



Torx-head screwdriver



# 99-5717

## INSTALLATION INSTRUCTIONS

**APPLICATIONS**

**CAR**

**PAGE**

FORD

Taurus 2004-2007.....1-3

MERCURY

Sable 2004-2007.....1-3



# ALL VEHICLES

1

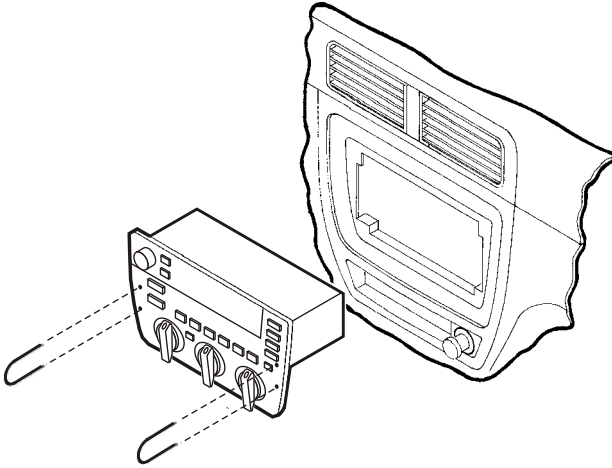

Disconnect the negative battery terminal to prevent an accidental short circuit. Using Metra's 86-5618, pull the factory radio/climate control panel from the dash. Disconnect the audio system connectors, blower motor switch connector, vacuum hose harness, a/c damper door switch connector, and potentiometer connector. Remove the panel.

2

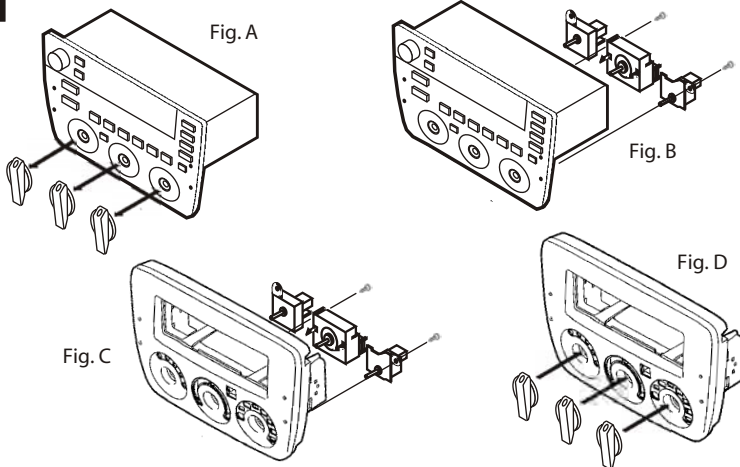

Turn the factory climate control dials into a vertical position and pull the dials off. (see Fig. A). Remove (2) 5/16" hex-head screws securing the temperature and fan control switches and remove the switches. Unclip the climate control switch and remove the switch. (see Fig. B). Mount the switches to the back of the Integrated Mounting Kit with (2) #8 x 3/8" Phillips Pan-head Screws supplied. (see Fig. C). Holding the climate control dials in a vertical position, insert the dials onto the posts of the mounted switches and secure. (see Fig. D)

3

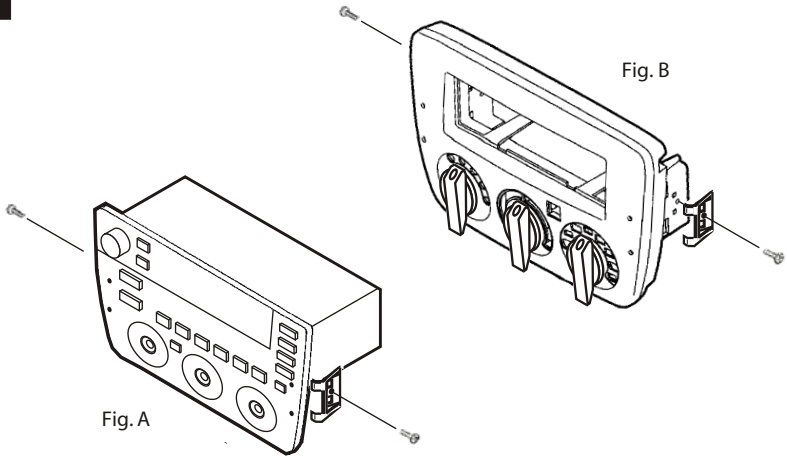

Remove (2) torx-head screws securing the mounting clips to the sides of the factory radio/climate control panel and remove the clips. (see Fig. A). Mount the clips to the Integrated Mounting Kit with the same torx-head screws. (see Fig. B)

4

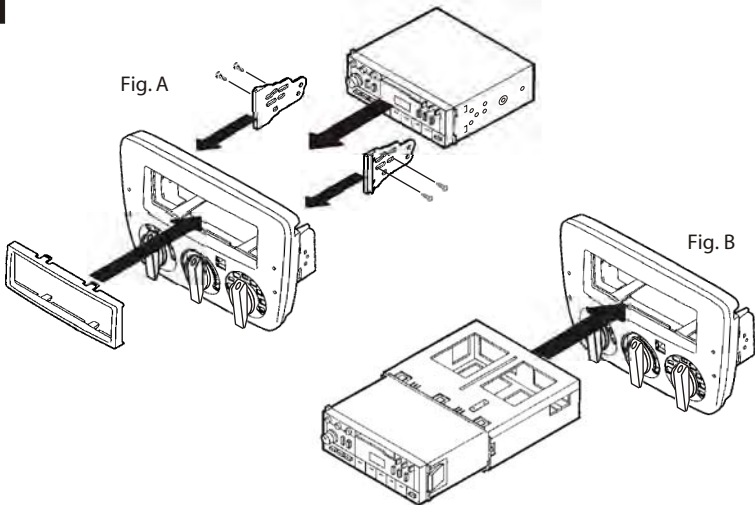

**ISO HEAD UNITS:** Snap the ISO Faceplate into the radio opening. Attach the ISO Brackets to the inner lip of the radio opening. Slide the head unit into the radio opening, align the holes in the head unit with the holes in the ISO Brackets and mount the unit to the brackets with the screws supplied with the unit. (see Fig. A).

**DIN HEAD UNITS:** Slide the DIN cage into the Integrated Mounting Kit and secure by bending the metal locking tabs down. Slide the aftermarket head unit into the cage and secure. (see Fig. B)

5

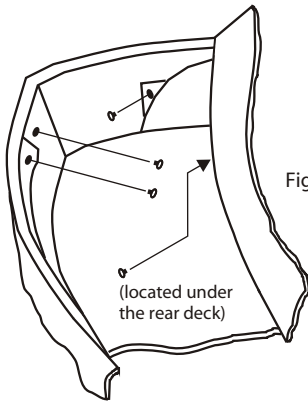

Fig. A

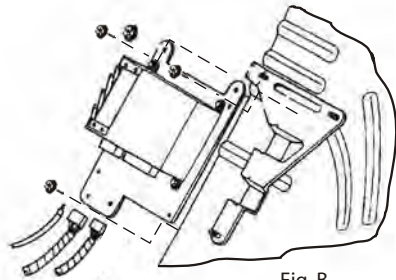
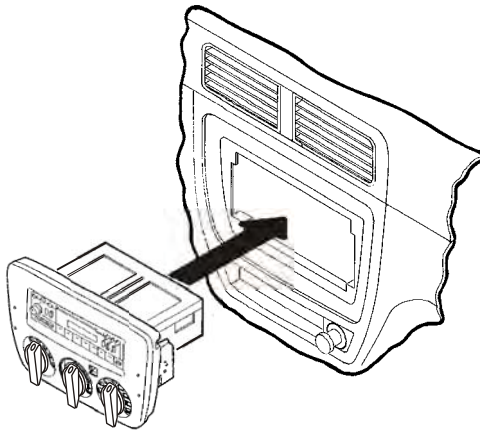

Fig. B

Open the trunk, remove (4) pop-clips from the driver's side trunk liner and remove the liner. (see Fig. A). Locate the factory tuner on the wall of the trunk and disconnect the speaker and antenna plugs (it is NOT necessary to remove the tuner). (see Fig. B). Plug the 70-5715 into the unit speaker plug and the antenna extension lead into the unit antenna plug. Slide the extension harness through the space in the back seat between the seat back and seat bottom. Unclip the rocker trim, tuck the extension harness under the carpet and stretch the harness to the back of the dash. (Replace the rocker trim when completed). Splice the speaker leads on the extension harness into the rear of the aftermarket head unit. Plug the factory wiring harnesses into the switch connectors (previously mounted in step #2) and audio connectors on the back of the Integrated Mounting Kit.

6



Re-connect the battery terminal and test the unit, climate controls and rear defroster for proper operation. Snap the Integrated Mounting Kit assembly into the sub-dash.