

## KIT FEATURES

- ▶ Shaft and DIN unit provisions
- ▶ Various mounting depth alternatives
- ▶ Incorporates factory climate controls into installation

## KIT COMPONENTS

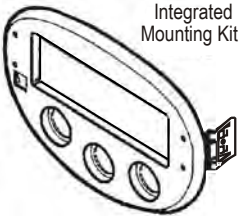

## TOOLS REQUIRED



86-5618 - Head unit removal keys



Torx-head screwdriver



Cutting tool



120995720



# 99-5720

## INSTALLATION INSTRUCTIONS

### APPLICATIONS

#### CAR

#### PAGE

#### FORD

|                    |     |
|--------------------|-----|
| Escort 1997-04     |     |
| Escort ZX2 1998-04 |     |
| ZX2 2003-04*       | 1-3 |

#### MERCURY

|                |     |
|----------------|-----|
| Tracer 1997-99 | 1-3 |
|----------------|-----|

\* Note: Metra's 70-5720 must be used on 2003-04 Zx2 and Escort Models



1-800-221-0932



[www.metraonline.com](http://www.metraonline.com)

© COPYRIGHT 2001-07 METRA ELECTRONICS CORPORATION

# ALL VEHICLES

1

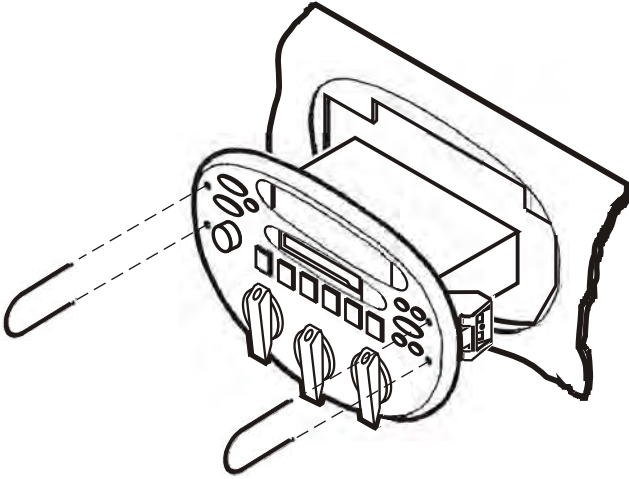

Disconnect the negative battery terminal to prevent an accidental short circuit. Reach under the driver's side dash and unclip the temperature control cable. Using Metra's 86-5618, pull the factory radio/climate control panel from the dash. Disconnect the switch power harness, antenna plug, radio/speaker power harnesses and vacuum hose harness.

2

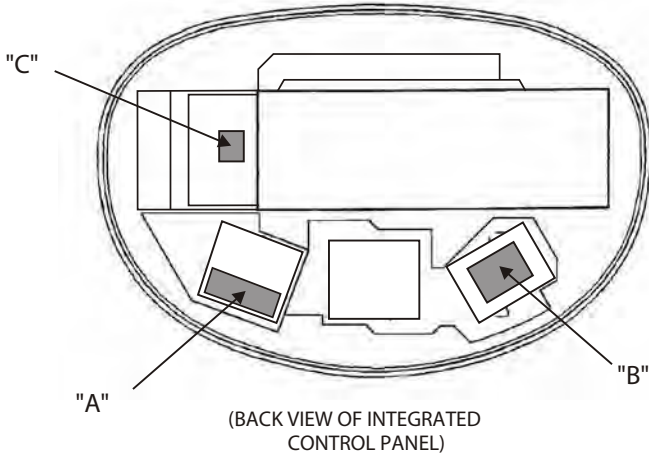

Turn the integrated control panel over and disconnect the vent control harness ("A"), fan speed control harness ("B"), and defroster harness ("C"). Unclip the main switch harness from the side of the factory unit. (This harness connects the fan speed control harness, vent control harness and defroster harness).

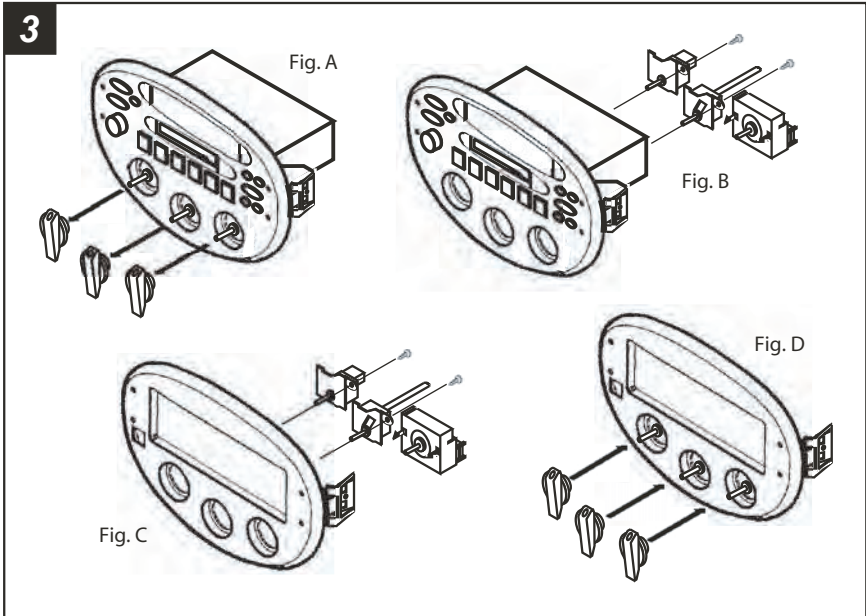

Turn the factory climate control dials into a vertical position and pull the dials off. (see Fig. A). Unclip the vent control switch and remove. Remove (2) torx-head screws securing the temperature control switch and fan speed control switch and remove. (see Fig. B). Mount the switches to the back of the Integrated Mounting Kit with the same torx-head screws. (see Fig. C). Holding the climate control dials in a vertical position, insert the dials onto the posts of the mounted switches and secure. (see Fig. D)

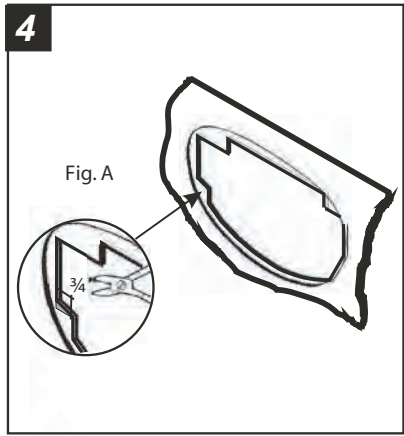

Cut and remove the shaded portion of the sub-dash lip. (see Fig. A)

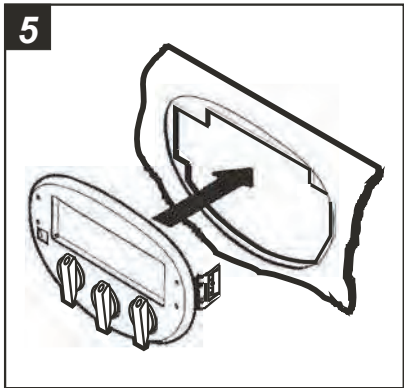

Make all wiring connections to the Integrated Mounting Kit and snap the assembly into the sub-dash. Reach under the driver's side dash and re-attach the temperature control cable.

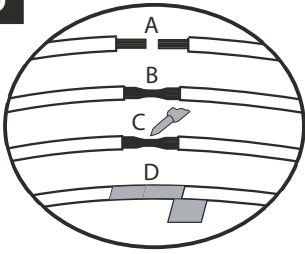
**6**

- A) Strip wire ends back 1/2"
- B) Twist ends together
- C) Solder
- D) Tape

- Right Front + .....Gray
- Right Front - .....Gray/Black
- Left Front + .....White
- Left Front - .....White/Black
- Right Rear + .....Violet
- Right Rear - .....Violet/Black
- Left Rear + .....Green
- Left Rear - .....Green/Black
- 12 Volt Power.....Red
- Memory.....Yellow
- Ground.....Black
- Power Antenna.....Blue
- Dimmer.....Orange/White
- Amp Turn-On.....Blue/White

NOTE: Ground head unit to vehicle

Locate the factory wiring harness in the dash. Metra recommends making connections as shown using the supplied wire harness. (Isolate and individually tape off the ends of any unused wires to prevent electrical short circuit).

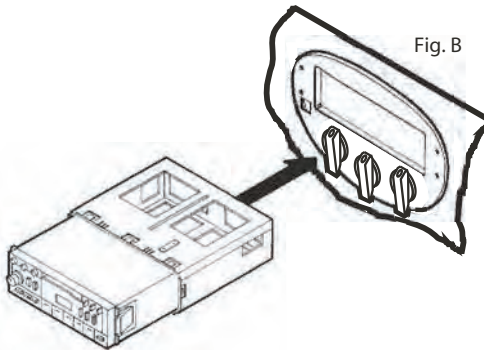
**7**

**DIN HEAD UNITS:** Slide the DIN cage into the Integrated Mounting Kit and secure by bending the metal locking tabs down. Slide the aftermarket head unit into the cage until secure. (see Fig. B)