

**KIT FEATURES**

- ▶ DIN unit provision
- ▶ Equalizer provision
- ▶ Pocket provision



# 99-5800

## INSTALLATION

## INSTRUCTIONS

**KIT COMPONENTS**

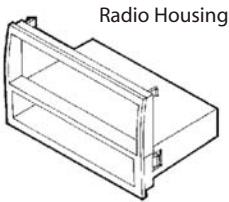

**APPLICATIONS**

<u>CAR</u>	<u>PAGE</u>
FORD	
Expedition 1997-98.....	1-3
F-150 1997-98.....	1-3

**TOOLS REQUIRED**



86-5618 - Head unit removal keys



Socket set



Cutting tool



Dremel tool



# ALL VEHICLES

1

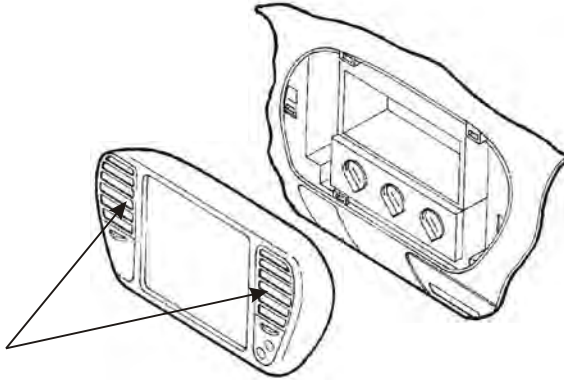

Disconnect the negative battery terminal to prevent an accidental short circuit. Place your index fingers on the inner edges of the a/c vents (shown above) and push inward. Grasp the exposed lip of each vent opening and pull out on the radio trim bezel. Remove the dash trim bezel. (The airbag wiring does NOT need to be disconnected). Using Metra's **86-5618**, pull the factory head unit from the dash and disconnect the wiring.

2

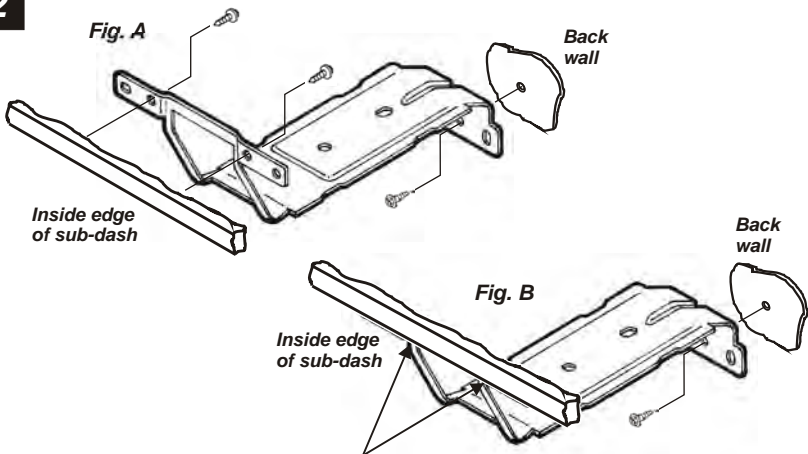

**REMOVE THE REAR SUPPORT BRACKET FROM THE DASH CAVITY USING ONE OF THE FOLLOWING METHODS:** Remove (1) 7mm hex-head bolt securing the bottom of the bracket to the back wall of the sub-dash and (2) 7mm hex-head bolts securing the top of the bracket to the inside edge of the sub-dash. Remove the bracket. (see Fig. A). OR Remove (1) 7mm hex-head bolt securing the bottom of the bracket to the back wall of the sub-dash and cut the bracket flush with the top edge of the radio opening. Remove the bracket. (see Fig. B)

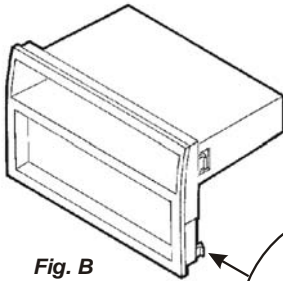
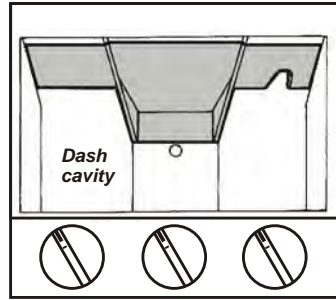
**3****Fig. B****Fig. A**

***IF THE RADIO OPENING IS DESIRED IN THE UPPER POSITION:*** Using a dremel tool, cut and remove the shaded portion of the dash cavity plastic. (see Fig. A).

***TO AVOID CUTTING THE DASH CAVITY PLASTIC:*** Trim the points off the mounting clips located on either side of the **Radio Housing**. (see Fig. B). Use the radio opening in the lower position for the remainder of the installation.

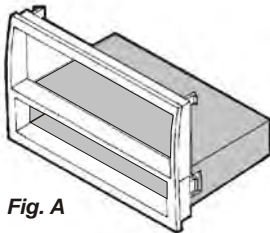
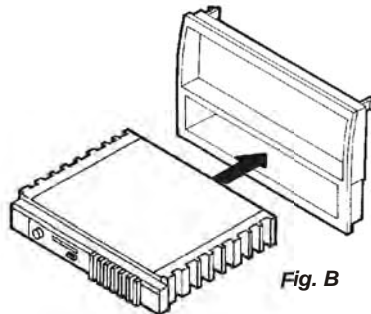
**4****Fig. A****Fig. B**

***IF AN EQUALIZER WILL NOT BE INCLUDED:*** Skip to step #5.

***IF AN EQUALIZER WILL BE INCLUDED:*** Cut and remove the pocket (shaded) from the **Radio Housing**. (see Fig. A). Slide the equalizer into the Housing and secure with plumber's tape. (see Fig. A)

5

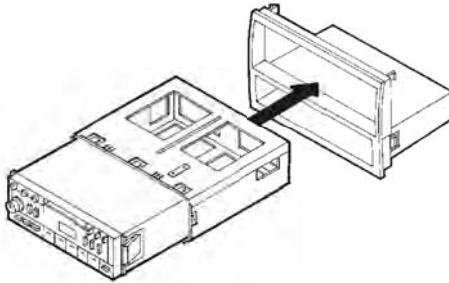

**DIN HEAD UNITS:** Slide the DIN cage into the Radio Housing and secure by bending the metal locking tabs outward. Slide the aftermarket head unit into the cage until it snaps into place.

6

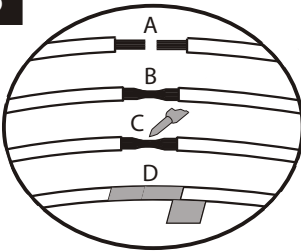

- A) Strip wire ends back ½"
- B) Twist ends together
- C) Solder
- D) Tape

Locate the factory wiring harness in the dash. Metra recommends using the proper mating adaptor and making connections as shown. (Isolate and individually tape off the ends of any unused wires to prevent electrical short circuit).

7

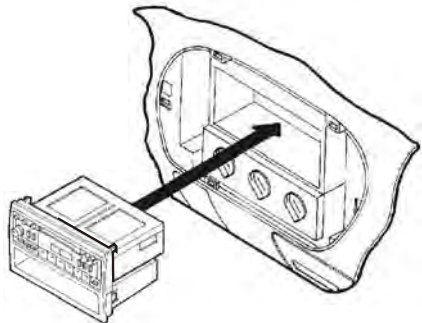

Re-connect the battery terminal and test the unit for proper operation. Snap the head unit/kit assembly into the sub-dash.