

**KIT FEATURES**

- ▶ *DIN head unit provisions*



# 99-5803

## INSTALLATION INSTRUCTIONS

**KIT COMPONENTS**

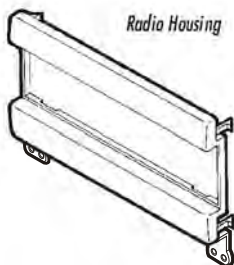

*Rear Support Bracket*

**APPLICATIONS**

**CAR**

**PAGE**

**FORD**

*Mustang 2001-03.....1-2*

**MERCURY**

*Cougar 1999-02.....1-2*

**TOOLS REQUIRED**



*86-5618 - Head unit removal keys*



*Socket wrench*



**1-800-221-0932**



**www.metraonline.com**

**© COPYRIGHT 2001 METRA ELECTRONICS CORPORATION**

rev. 201202

## FORD Mustang 2001-03

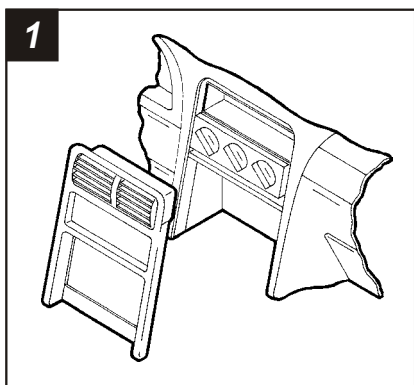

1  
Disconnect the negative battery terminal to prevent an accidental short circuit. Unclip the gear shifter trim and remove. Unclip the radio/climate control trim bezel and remove. Remove (2) 7mm hex-head screws from the factory head unit and disconnect the wiring.

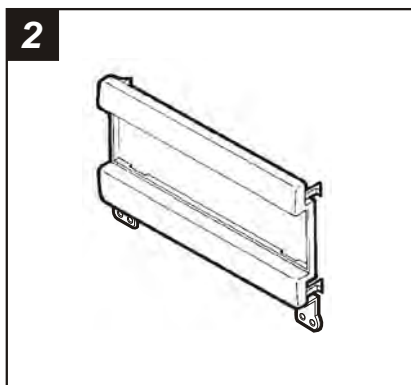

2  
Locate the **Radio Housing**. Skip to the *Installation Instructions for ALL VEHICLES on Page #2*.

## MERCURY Cougar 1999-02

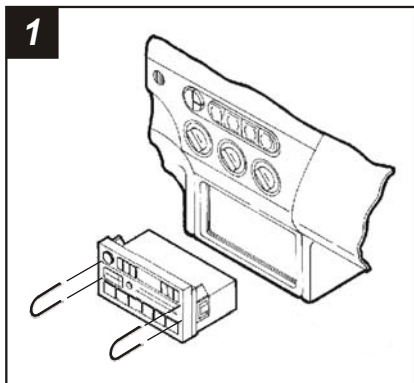

1  
Disconnect the negative battery terminal to prevent an accidental short circuit. Using Metra's **86-5618**, pull the factory head unit from the dash and disconnect the wiring.

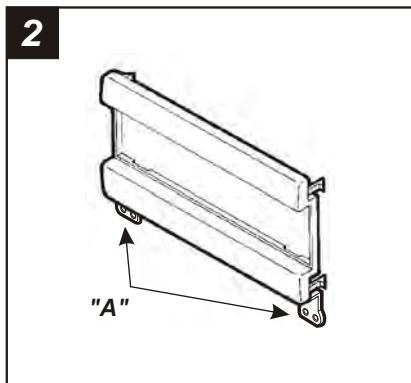

2  
Cut and remove tabs "A" from the **Radio Housing**. Skip to the *Installation Instructions for ALL VEHICLES on Page #2*.

## ALL VEHICLES

3

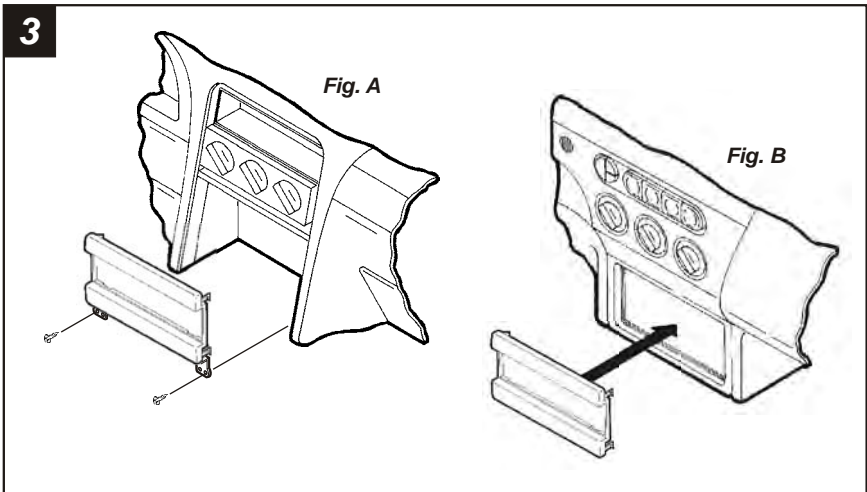

**MUSTANG:** Mount the **Radio Housing** to the sub-dash with (2) 7mm hex-head screws previously removed in step #1 (Fig. A).

**COUGAR:** Snap the **Radio Housing** into the sub-dash (Fig. B).

4

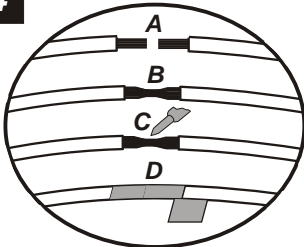

- A) Strip wire ends back  $\frac{1}{2}$ "
- B) Twist ends together
- C) Solder
- D) Tape

Locate the factory wiring harness in the dash. Metra recommends using the proper mating adaptor and making connections as shown. (Isolate and individually tape off the ends of any unused wires to prevent electrical short circuit).

5

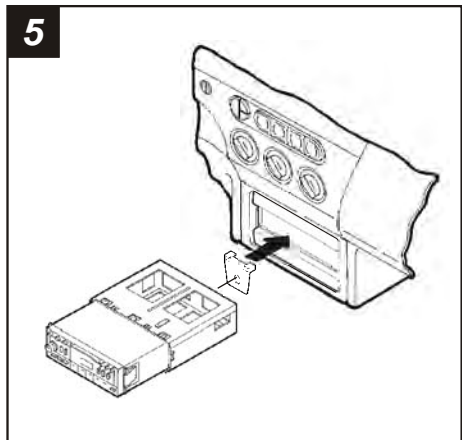

Re-connect the battery terminal and test the unit for proper operation. Mount the **Rear Support Bracket** to the back of the DIN cage. Slide the cage into the mounted **Radio Housing** and secure by bending the metal locking tabs down. Slide the aftermarket head unit into the mounted cage until secure.