



INSTALLATION INSTRUCTIONS FOR PART 99-5814

APPLICATIONS

FORD Escape 2008-2009
MERCURY Mariner 2008-2009
MAZDA Tribute 2008-2009

99-5814/ 99-5814S

KIT FEATURES

- DIN Radio Provision with Pocket
 - ISO Mount Radio Provision with Pocket
 - Double DIN Radio Provision
 - Stacked ISO Mount Units Provision
- Painted to match factory dash:**
99-5814=Black, 99-5814S=Silver



KIT COMPONENTS

- A) Radio Housing • B) ISO Brackets • C) Trim Plate • D) Double DIN Brackets
- E) Double DIN Trim Plate • F) Pocket • G) (2) Spare Radio Housing Panel Clips

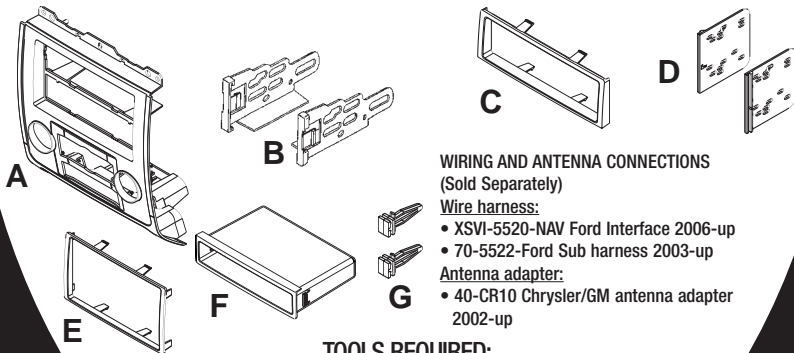

TOOLS REQUIRED:

- Small Flat Blade Screwdriver/ Panel Removal Tool
- Socket Set



1-800-221-0932



www.metraonline.com

© COPYRIGHT 2004-2009 METRA ELECTRONICS CORPORATION

TABLE OF CONTENTS

Dash Disassembly

- Ford Escape 2008-2009 1,2**
- Mercury Mariner 2008-2009 1,2**
- Mazda Tribute 2008 -2009. 1,2**

Kit Assembly

- Kit Preparation 3**
- DIN Radio Provision with Pocket4**
- ISO Mount Radio Provision with Pocket. 5**
- Double DIN Radio Provision 6**
- Stacked ISO Mount Units Provision 7**

Note:

Refer also to the instructions included with the aftermarket radio.

Note:

There are (2) extra radio housing panel clips included with the kit in case removal of the kit is necessary at any time.



KNOWLEDGE IS POWER

Enhance your installation and fabrication skills by enrolling in the most recognized and respected mobile electronics school in our industry. Log onto www.installerinstitute.com or call 800-354-6782 for more information and take steps toward a better tomorrow.

FORD ESCAPE 2008-2009
MERCURY MARINER 2008-2009
MAZDA TRIBUTE 2008-2009

- 1 Disconnect the negative battery terminal to prevent an accidental short circuit.
- 2 Unclip and remove the a/c vent panel above the radio. (Figure A)
- 3 Remove the (2) 7 MM screws exposed at the top of the factory radio panel. (Figure B)
- 4 Unclip the accessory socket/switch /aux input panel below the radio. Unplug and remove the panel. (Figure C)

Continue on page 2.

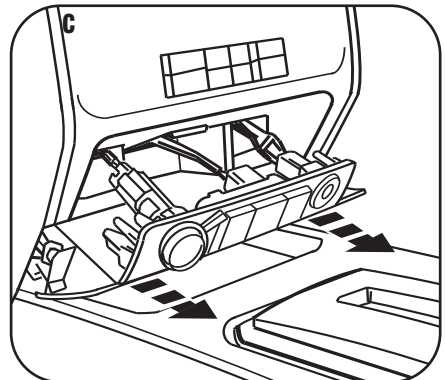
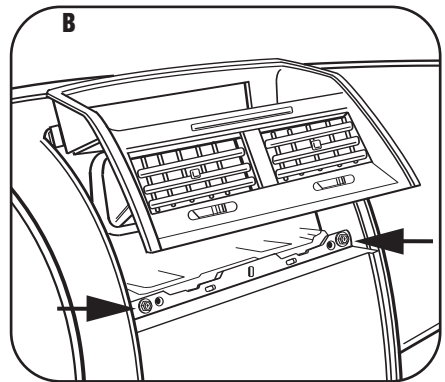
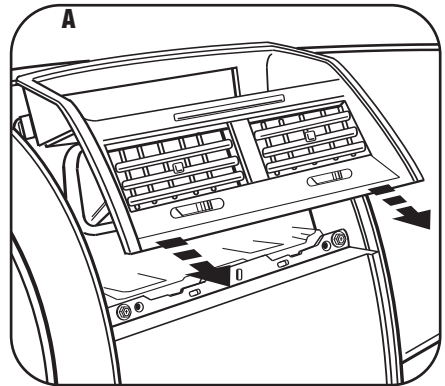

FORD ESCAPE 2008-2009
MERCURY MARINER 2008-2009
/MAZDA TRIBUTE 2008-2009

- 5** Remove the (2) 7 MM screws exposed at the bottom of the factory radio panel. (Figure D)
- 6** Slide radio out and remove (1) 8mm bolt from the right side securing the ground strap to the radio brackets. Unplug and remove the radio.
- 7** Remove (4) Torx screws securing the climate controls to the factory radio panel. Remove the climate controls and retain them with the factory screws for use during kit assembly. (Figure E)

Continue to kit assembly

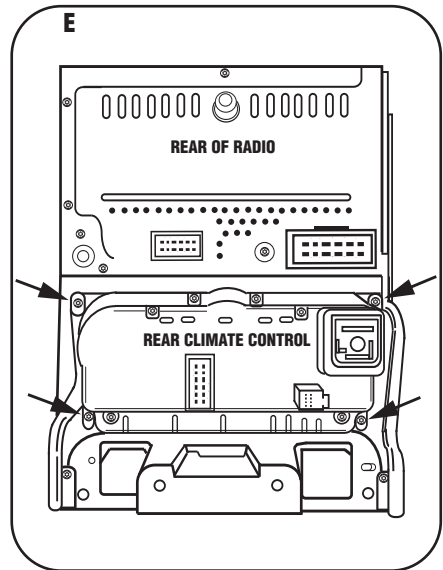
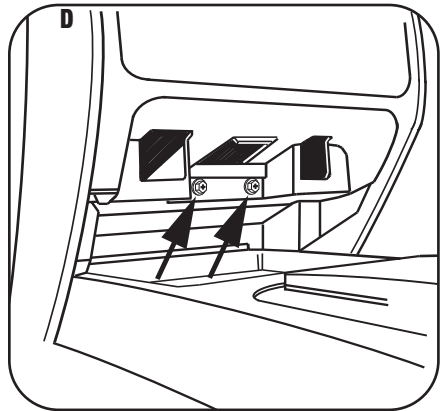

KIT PREPARATION

- 1 Attach the climate control to the radio housing using the factory hardware removed in step 7 of dash disassembly. (Figure A)

Note: There are (2) extra radio housing panel clips included with the kit in case removal of the kit is necessary at any time. (Figure B)

Continue to kit assembly.

A

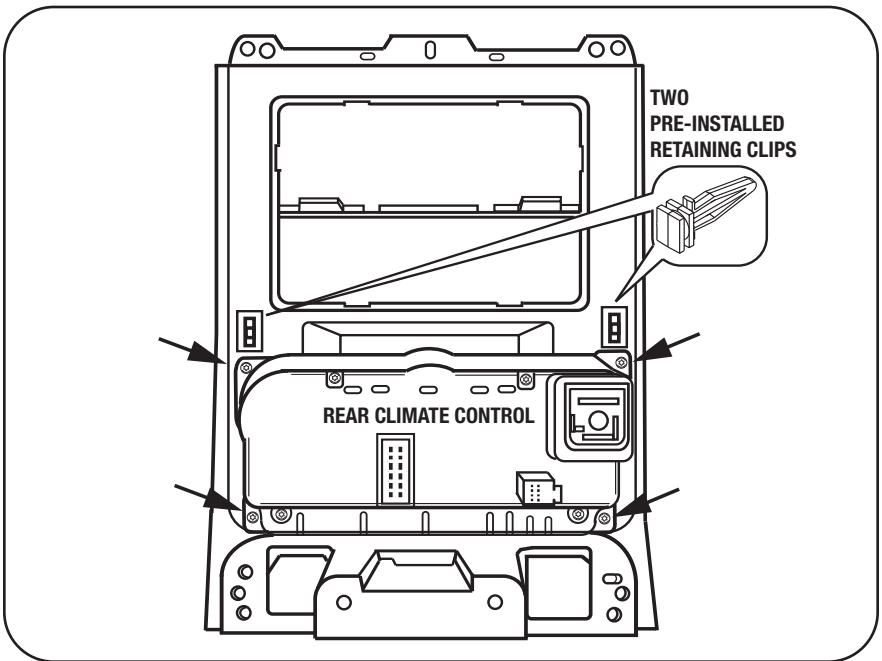

B

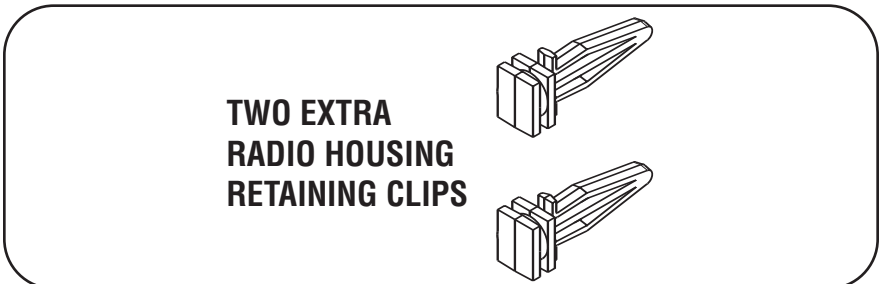

DIN MOUNT RADIO PROVISION WITH POCKET

**Note: Refer also to the instructions included with the aftermarket radio.*

- 1 Slide the DIN cage into the radio housing and secure by bending the metal locking tabs outward. (Figure A)
- 2 Slide the aftermarket radio into the DIN cage and until it snaps into place. (Figure B)
- 3 Snap the pocket into the radio housing. (Figure C)

Continue to final assembly.

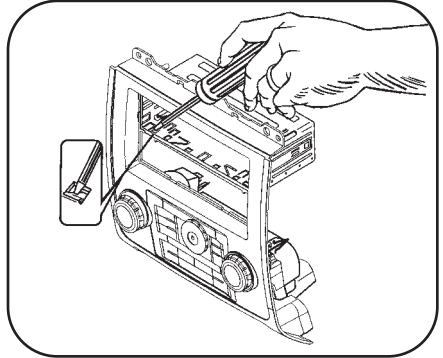
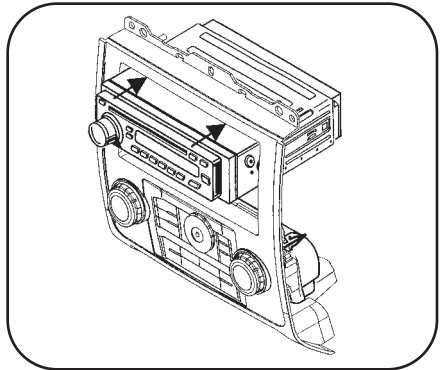
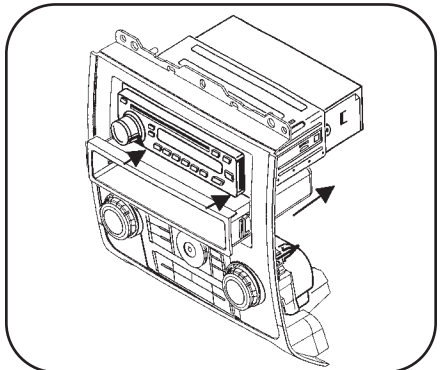
A

B

C

ISO MOUNT RADIO PROVISION WITH POCKET

**Note: Refer also to the instructions included with the aftermarket radio.*

- 1 Mount the ISO Brackets to the radio using the screws supplied with the radio. (Figure A)
- 2 Slide the radio into the radio housing until it snaps into place. (Figure B)
- 3 Snap the trim plate onto the front of the Radio Housing. (Figure B)
- 4 Snap the Pocket into the radio housing. (Figure C)

Continue to final assembly.

A

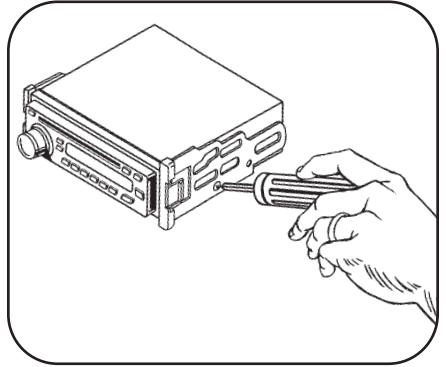

B

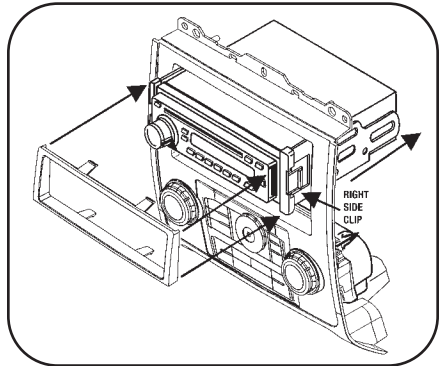

C

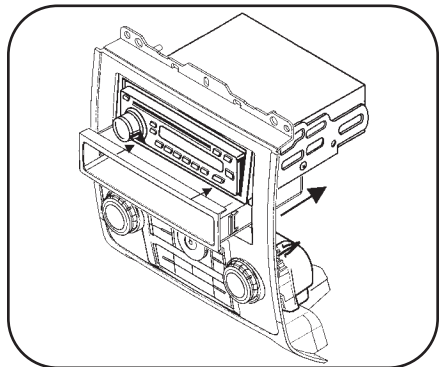

DOUBLE DIN RADIO PROVISION

**Note: Refer also to the instructions included with the aftermarket radio.*

- 1 Cut and remove the center bar from the radio housing. (Figure A)
- 2 Snap the Double DIN brackets to the inside edge of the radio housing. (Figure B)
- 3 Slide the Double DIN radio into the DDIN bracket/radio housing assembly and secure the radio to the assembly using the screws supplied with the radio. (Figure C)
- 4 Snap the Double DIN trim plate onto the front of the radio/housing assembly. (Figure C)

Continue to final assembly.

A

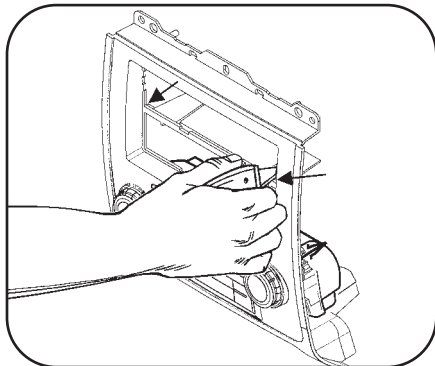

B

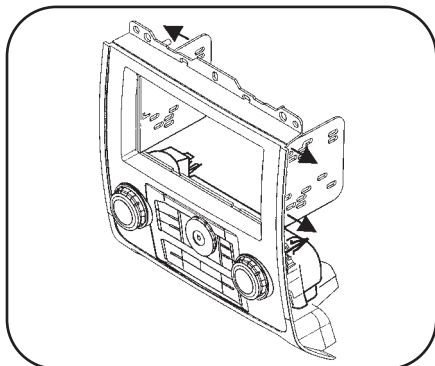

C

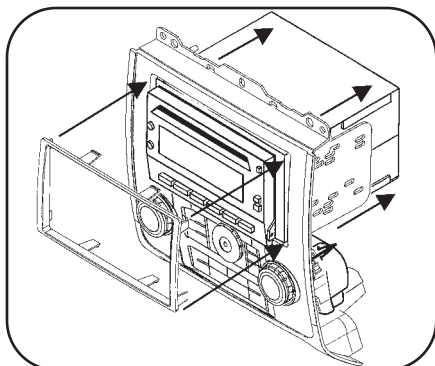

STACKED ISO MOUNT UNITS PROVISION

**Note: Refer also to the instructions included with the aftermarket radio.*

- 1 Cut and remove the center bar from the radio housing. (Figure A)
- 2 Snap the Double DIN brackets to the inside edge of the radio housing. (Figure B)
- 3 Slide the stacked ISO mount units into the bracket/housing assembly and secure the units to the assembly using the screws supplied with the units. (Figure C)
- 4 Snap the Double DIN trim plate onto the front of the radio/housing assembly. (Figure C)

Continue to final assembly.

A

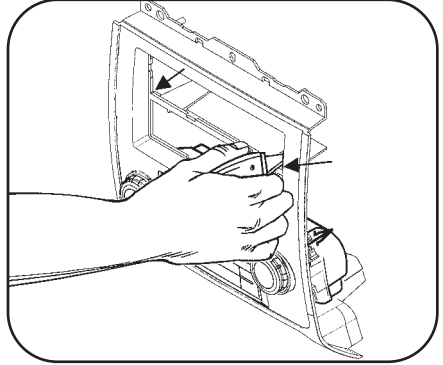

B

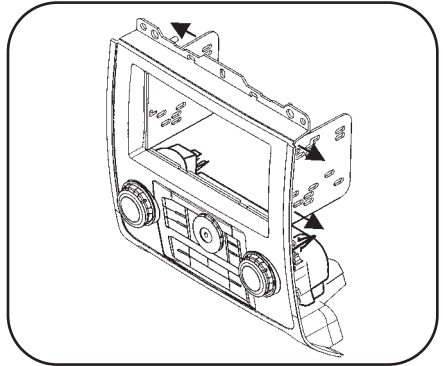

C

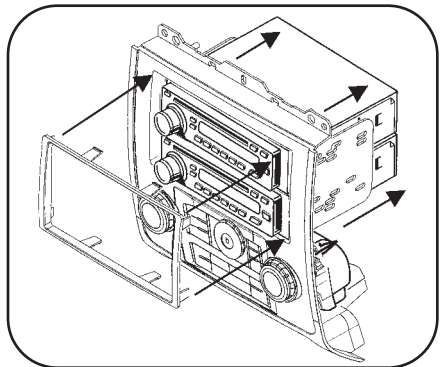

FINAL ASSEMBLY

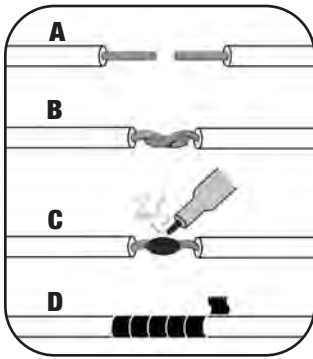

- (A) Strip wire ends back 1/2"**
- B) Twist ends together**
- C) Solder**
- D) Tape**

- 1** Locate the factory wiring harness in the dash. Metra recommends using the proper mating adapter and making connections as shown. (Isolate and individually tape off the ends of any unused wires to prevent electrical short circuit.)
- 2** Re-connect the negative battery terminal and test the unit for proper operation.
- 3** Reassemble radio and dash assemblies in reverse order of disassembly.

FINAL WIRING CONNECTIONS

Make wiring connections using the EIA color code chart shown below and the instructions included with the head unit. Metra recommends making connections as shown below; Strip, Splice, Solder, Tape. Isolate and individually tape off ends of any unused wires to prevent electrical short circuit.

METRA / EIA WIRING CODE

12V Ignition / Acc.	Red	Right Front (+)	Gray
12V Batt / Memory.	Yellow	Right Front (-).	Gray/ Black
Ground.	Black*	Left Front (+)	White
Power Antenna.	Blue	Left Front (-).	White / Black
Amp Turn-On	Blue / White	Right Rear (+)	Violet
Amp Ground.	Black / White	Right Rear (-).	Violet / Black
Illumination	Orange	Left Rear (+)	Green
Dimmer	Orange / White	Left Rear (-)	Green / Black

*NOTE: When a Black wire is not present, ground radio to vehicle chassis.
All colors may not be present on all leads due to manufacturer's specifications.

99-5814 INSTRUCTIONS



1-800-221-0932



www.metraonline.com

REV. 05/26/09 © COPYRIGHT 2004-2009 METRA ELECTRONICS CORPORATION INST99-5814