



INSTALLATION INSTRUCTIONS FOR PART 99-6229

APPLICATIONS

Chrysler Multi Kit

NOTE: It may be necessary to modify the back of the radio cavity in some cars to accommodate some deeper aftermarket radios.

99-6229

KIT FEATURES

- DIN Mount Radio Provision



KIT COMPONENTS

- A) Radio Housing

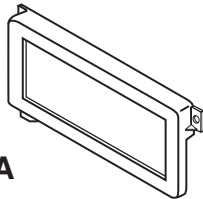

A

TOOLS REQUIRED:

- A) Phillips Screwdriver • B) Socket Set • C) Torx Driver • D) Panel Removal Tool or Flat Blade Screwdriver

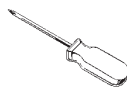
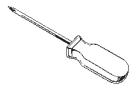

1-800-221-0932



www.metraonline.com

© COPYRIGHT 2004 METRA ELECTRONICS CORPORATION



99-6229

TABLE OF CONTENTS

Dash Disassembly

CHRYSLER

<i>Concord 1993-97</i>	1
<i>Cordoba 1975-78</i>	1
<i>Cordoba 1979-83</i>	2
<i>E-Class 1983-84</i>	2
<i>Fifth Avenue 1990-94</i>	3
<i>Imperial 1982-83</i>	2
<i>Imperial 1990-94</i>	3
<i>Laser 1984-89</i>	3
<i>LeBaron 1976-81</i>	4
<i>LeBaron 1982-85</i>	2
<i>LeBaron 1986-95</i>	4
<i>LeBaron GTS 1985-94</i>	5
<i>LHS 1995-98</i>	1
<i>Newport 1980-81</i>	2
<i>New Yorker 1980-81</i>	2
<i>New Yorker 1983-87</i>	2
<i>New Yorker 1988-95</i>	3
<i>Town & Country 1990-92</i>	5
<i>Town & Country 1993</i>	6
<i>Town & Country 1994-95</i>	6
<i>Town & Country 1996-2000</i>	7

DODGE

<i>Aries 1981-89</i>	2
<i>Aspen 1976-80</i>	4
<i>Caravan 1984-90</i>	5
<i>Caravan 1991-93</i>	6
<i>Caravan 1994-95</i>	6

DODGE (continued)

<i>Caravan 1996-2000</i>	7
<i>Charger 1983-87</i>	7
<i>Charger 1974-78</i>	1
<i>Dakota 1987-96</i>	8
<i>Dakota 1997-2000</i>	8
<i>Daytona 1984-89</i>	3
<i>Daytona 1990-93</i>	9
<i>Diplomat 1976-89</i>	4
<i>Durango 1997-2000</i>	8
<i>Dynasty 1988-93</i>	3
<i>Intrepid 1993-97</i>	1
<i>Lancer 1985-89</i>	5
<i>Magnum 1978-79</i>	1
<i>Mirada 1980-83</i>	2
<i>Neon 1995-99</i>	9
<i>Omni 1978-82</i>	10
<i>Pickup 1974-80</i>	10
<i>Pickup 1981-93</i>	11
<i>Ram 1994-97</i>	11
<i>Ram 1998-2002</i> <i>(2002 Ram 2500 & 3500 models only)</i>	12
<i>Ramcharger 1974-80</i>	10
<i>Ramcharger 1981-93</i>	11
<i>Rampage 1978-82</i>	10
<i>Shadow 1987-94</i>	12
<i>Spirit 1989-95</i>	13
<i>St. Regis 1979-81</i>	2

(continued on next page)

NOTE: It may be necessary to modify the back of the radio cavity in some cars to accommodate some deeper aftermarket radios.



TABLE OF CONTENTS

Dash Disassembly

DODGE (continued)

Van (full size) 1978-97.....13
Van (full size) 1998-2003.....14
024 1978-82.....10
400 1982-83.....2
600 1983-87.....2

EAGLE

Vision 1993-97.....1

JEEP

Cherokee 1997-01.....14
Grand Cherokee 1996-98.....15
Wrangler 1997-02.....15

PLYMOUTH

Acclaim 1989-95.....13
Caravelle 1985-87.....2
Fury 1975-78.....1

PLYMOUTH (continued)

Gran Fury 1975-85.....4
Horizon 1978-82.....10
Neon 1995-99.....9
Reliant 1981-89.....2
Scamp 1983-84.....10
Sundance 1987-94.....12
TC3 1978-82.....10
Trailduster 1974-80.....10
Trailduster 1981.....11
Turismo 1983-87.....7
Van (full size) 1978-83.....13
Volare 1976-80.....4
Voyager 1984-90.....5
Voyager 1991-93.....6
Voyager 1994-95.....6
Voyager 1996-2000.....7

Kit Assembly

- DIN Mount Radio Provision 16

Final Assembly17

NOTE: It may be necessary to modify the back of the radio cavity in some cars to accommodate some deeper aftermarket radios.



99-6229 DASH DISASSEMBLY

CHRYSLER CONCORD / DODGE INTREPID 1993-97

EAGLE VISION 1993-97 / CHRYSLER LHS 1995-98

- 1 Disconnect the negative battery terminal to prevent an accidental short circuit.
- 2 Unclip and remove the radio trim panel.
- 3 Remove the (2) 3/8" hex head screws securing the radio.
- 4 Unplug and remove the radio.
- 5 Continue to Kit Assembly.

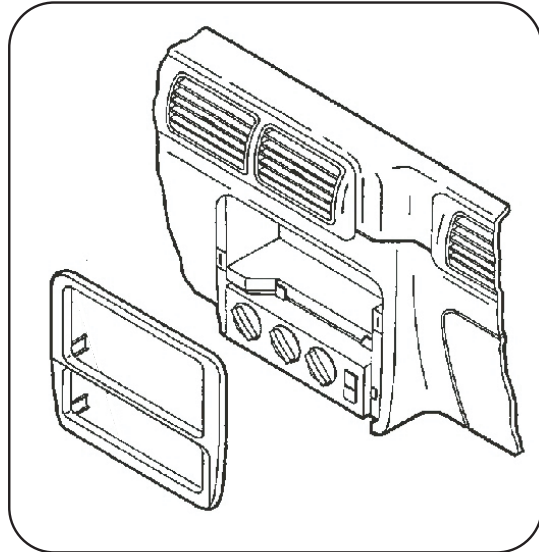

CHRYSLER CORDOBA / PLYMOUTH FURY 1975-78

DODGE CHARGER 1974-78 DODGE MAGNUM 1978-79

- 1 Disconnect the negative battery terminal to prevent an accidental short circuit.
- 2 Remove (4) Phillips head screws from bottom edge of radio trim panel.
- 3 Remove (2) Phillips head screws from above the radio opening.
- 4 Unscrew and remove the trim ring around the remote mirror control.
- 5 Remove radio trim panel.
- 6 Remove (2) 3/8" hex head screws securing the radio.
- 7 Unplug and remove the radio.
- 8 Continue to Kit Assembly.

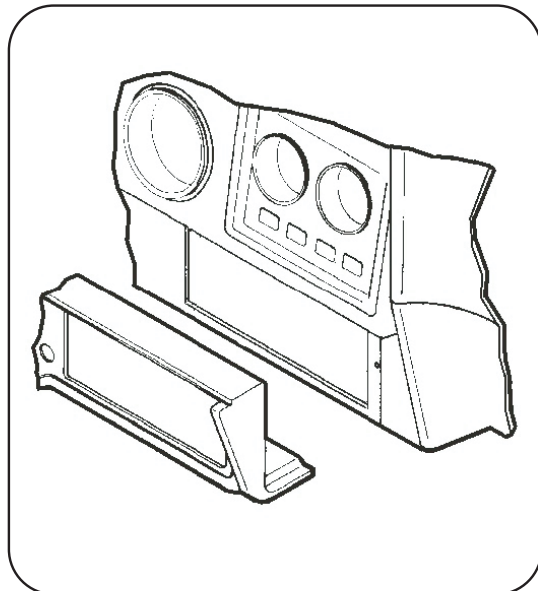

CHRYSLER CORDOBA 1979-83 / CHRYSLER IMPERIAL 1982-83

CHRYSLER NEWPORT / NEW YORKER 1980-81

DODGE MIRADA 1980-83 / DODGE ST. REGIS 1979-81

- 1 Disconnect the negative battery terminal to prevent an accidental short circuit.
- 2 Remove (2) Phillips head screws from above the radio opening.
- 3 Remove (2) Phillips head screws from above climate controls.
- 4 Unclip and remove radio trim panel.
- 5 Remove (2) 3/8" hex head screws securing the radio.
- 6 Unplug and remove radio.
- 7 Continue to Kit Assembly.

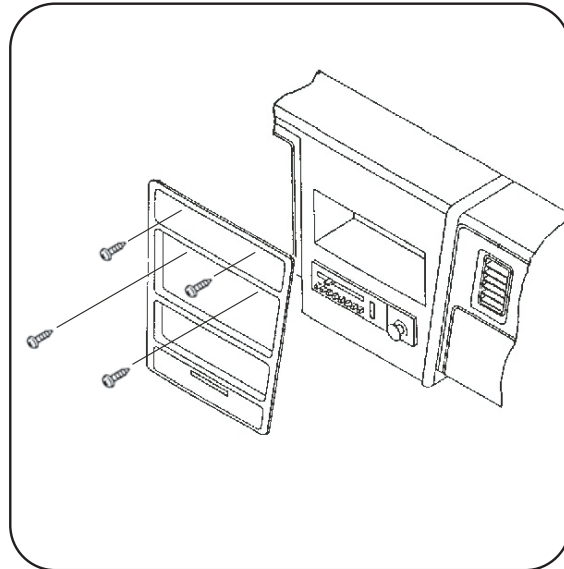

CHRYSLER E-CLASS 1983-84 / CHRYSLER LEBARON 1982-85

CHRYSLER NEW YORKER / DODGE 600 1983-87 / DODGE ARIES 1981-89

DODGE 400 1982--83 / PLYMOUTH CARAVELLE 1985-87

PLYMOUTH RELIANT 1981-89

- 1 Disconnect the negative battery terminal to prevent an accidental short circuit.
- 2 Remove (3) Phillips head screws from top edge of the dash trim panel.
- 3 Remove (3) Phillips head screws from bottom edge of the dash trim panel.
- 4 Unclip and remove the dash trim panel.
- 5 Remove (2) 3/8" hex head screws securing the radio.
- 6 Unplug and remove the radio.
- 7 Continue to Kit Assembly.

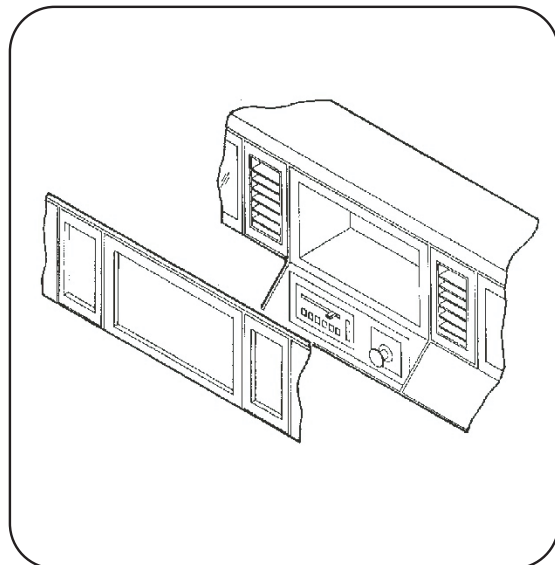

CHRYSLER FIFTH AVENUE / IMPERIAL 1990-94**CHRYSLER NEW YORKER 1988-95****DODGE DYNASTY 1988-93**

- 1 Disconnect the negative battery terminal to prevent an accidental short circuit.
- 2 Remove (5) Phillips head screws from top edge of the dash trim panel.
- 3 Unclip and remove dash trim panel
- 4 Remove (2) 3/8" hex head screws securing the radio.
- 5 Unplug and remove the radio.
- 6 Continue to Kit Assembly.

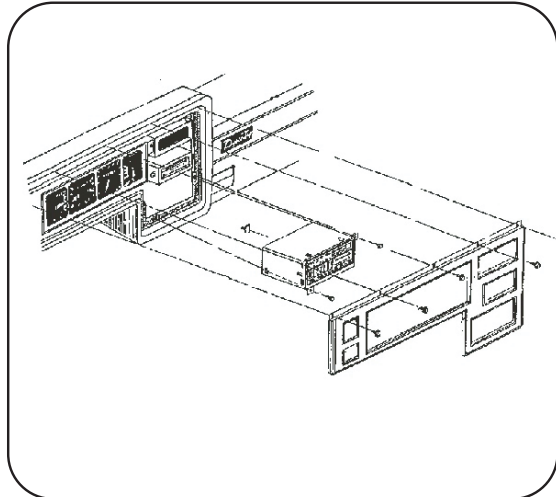

CHRYSLER LASER / DODGE DAYTONA 1984-89

- 1 Disconnect the negative battery terminal to prevent an accidental short circuit.
- 2 Remove (2) Phillips head screws from the bottom corners of the center dash trim panel.
- 3 Pull out the lower edge of the center dash trim panel to remove panel.
- 4 Remove (2) 3/8" hex head screws securing the radio.
- 5 Unplug and remove the radio.
- 6 Continue to Kit Assembly.

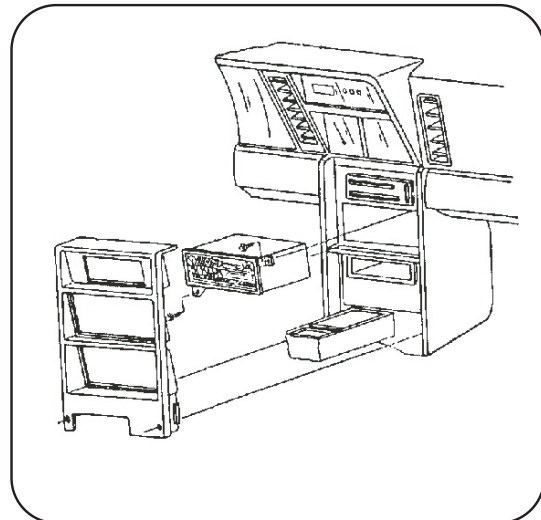

CHRYSLER LEBARON 1976-81 / DODGE DIPLOMAT 1976-89**DODGE ASPEN / PLYMOUTH VOLARE 1976-80****PLYMOUTH GRAN FURY 1975-85**

- 1 Disconnect the negative battery terminal to prevent an accidental short circuit.
- 2 Remove (4) Phillips head screws from top edge of the dash trim panel.
- 3 Remove (4) Phillips head screws from bottom edge of the dash trim panel.
- 4 Remove the dash trim panel.
- 5 Remove (2) 3/8" hex head screws securing the radio.
- 6 Unplug and remove the radio.
- 7 Continue to Kit Assembly.

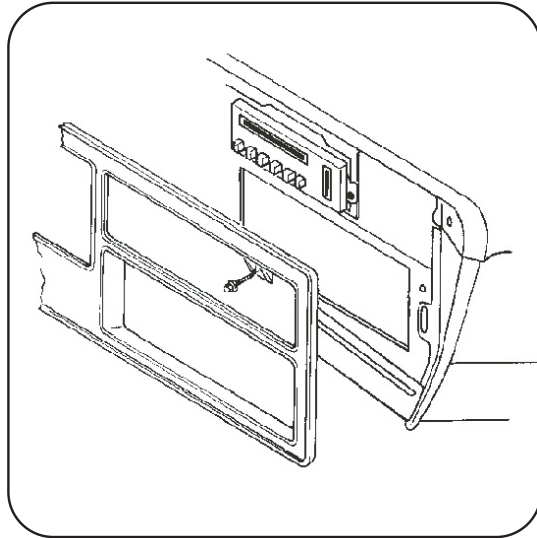
**CHRYSLER LEBARON 1986-95**

- 1 Disconnect the negative battery terminal to prevent an accidental short circuit.
- 2 Remove (1) Phillips head screw from the bottom corners of the center dash trim panel.
- 3 Unclip and remove the center dash trim panel.
- 4 Remove (2) Phillips head screws from the right side trim panel of the center dash console and remove the side trim panel.
- 5 Remove (2) 3/8" hex head screws securing the radio.
- 6 Unplug and remove the radio.
- 7 Continue to Kit Assembly.

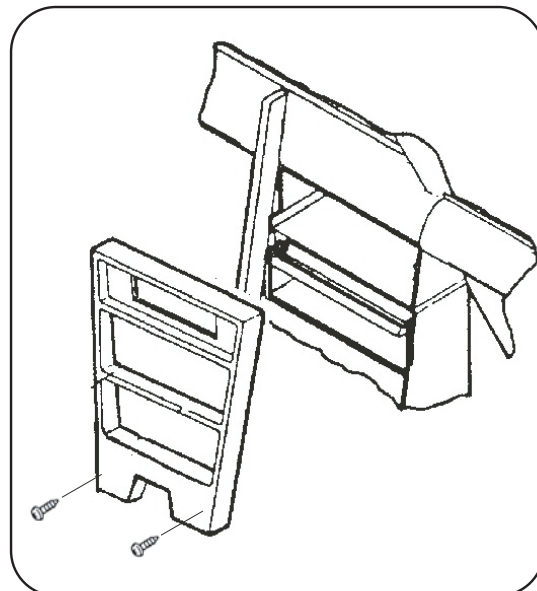



99-6229 DASH DISASSEMBLY

CHRYSLER LEBARON GTS 1985-94 DODGE LANCER 1985-89

- 1 Disconnect the negative battery terminal to prevent an accidental short circuit.
- 2 Remove (5) Torx head screws from the top edge of the dash trim panel.
- 3 Remove (2) Torx head screws from below the radio.
- 4 Remove (1) Torx head screw from above top left corner of radio.
- 5 Remove (4) Torx head screws from lower left side of the dash trim panel.
- 6 Unclip and remove the dash trim panel.
- 7 Remove (2) 3/8" hex head screws securing the radio.
- 8 Unplug and remove the radio.
- 9 Continue to Kit Assembly.

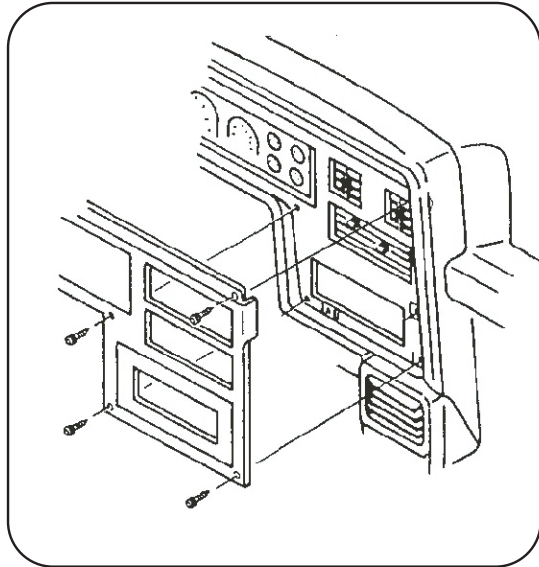

CHRYSLER TOWN & COUNTRY 1990-92

DODGE CARAVAN / PLYMOUTH VOYAGER 1984-90

- 1 Disconnect the negative battery terminal to prevent an accidental short circuit.
- 2 Reach behind the ashtray and release the rear tab on the ashtray housing to remove the ashtray.
- 3 Remove (2) screws from the bottom edge of the dash trim panel.
- 4 Remove (3) screws from the top edge of the dash trim panel.
- 5 Unsnap and remove the panel.
- 6 Remove (2) 3/8" hex head screws securing the radio.
- 7 Unplug and remove the radio.
- 8 Continue to Kit Assembly.

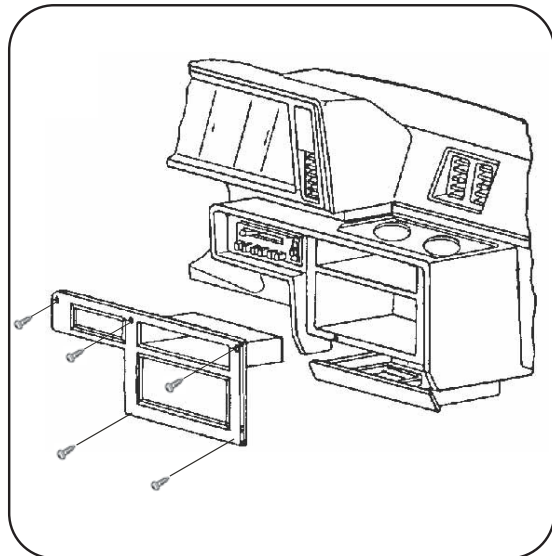



99-6229 DASH DISASSEMBLY

CHRYSLER TOWN & COUNTRY 1993 DODGE CARAVAN / PLYMOUTH VOYAGER 1991-93

- 1 Disconnect the negative battery terminal to prevent an accidental short circuit.
- 2 Remove the cigarette lighter.
- 3 Using a panel removal tool pry out and remove the radio trim panel.
- 4 Remove (2) 3/8" hex head screws securing the radio.
- 5 Unplug and remove the radio.
- 6 Continue to Kit Assembly.

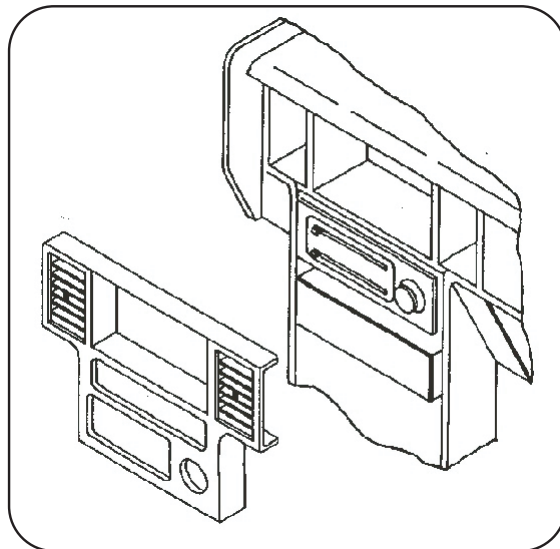

CHRYSLER TOWN & COUNTRY 1994-95

DODGE CARAVAN / PLYMOUTH VOYAGER 1994-95

- 1 Disconnect the negative battery terminal to prevent an accidental short circuit.
- 2 Using a panel removal tool, pry up front edge of top dash panel cover speakers and pull the panel toward you to remove it.
- 3 Unsnap and remove trim panel grille.
- 4 Remove (6) Phillips head screws securing the message center assembly.
- 5 Unplug and remove message center assembly.
- 6 Unsnap and remove climate control trim panel.
- 7 Remove (3) Phillips head screws from bottom edge of radio/instrument trim panel.

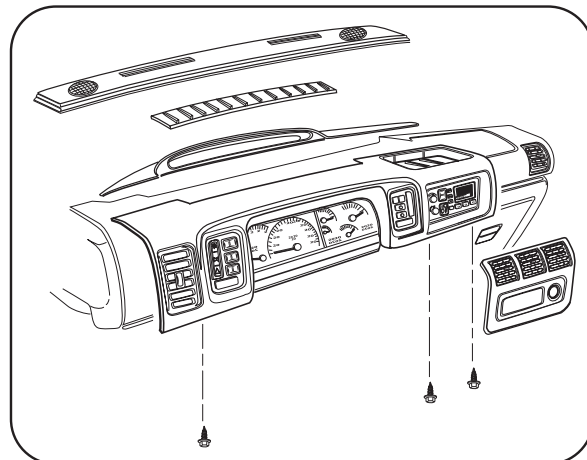

- 8 Unsnap and remove radio/instrument trim panel.
- 9 Remove (2) 3/8" hex head screws securing the radio.
- 10 Unplug and remove the radio.
- 11 Continue to Kit Assembly.

CHRYSLER TOWN & COUNTRY 1996-2000
PLYMOUTH VOYAGER / DODGE CARAVAN 1996-2000

- 1 Disconnect the negative battery terminal to prevent an accidental short circuit.
- 2 Open the ashtray and remove the trim above the ashtray by unsnapping the trim.
- 3 Remove (2) Phillips head screws from above ashtray.
- 4 Remove (2) screws from above the radio.
- 5 Unclip the radio trim panel and unplug the climate controls wires to remove the panel.
- 6 Remove (2) 3/8" hex head screws securing the radio.
- 7 Unplug and remove the radio.
- 8 Continue to Kit Assembly.

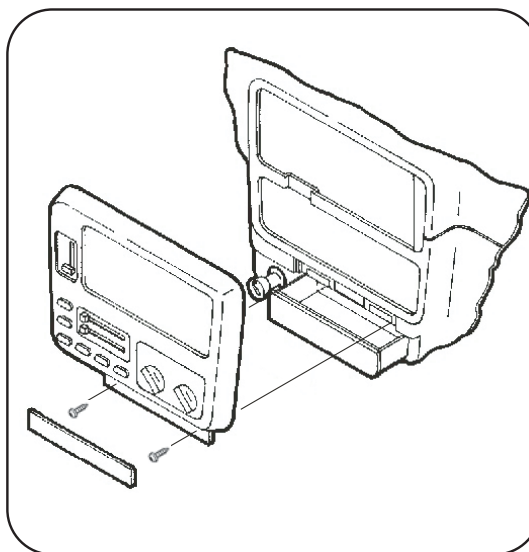

DODGE CHARGER / PLYMOUTH TURISMO 1983-87

- 1 Disconnect the negative battery terminal to prevent an accidental short circuit.
- 2 Unclip and remove radio trim panel.
- 3 Remove (2) 3/8" hex head screws securing the radio.
- 4 Unplug and remove the radio.
- 5 Continue to Kit Assembly.

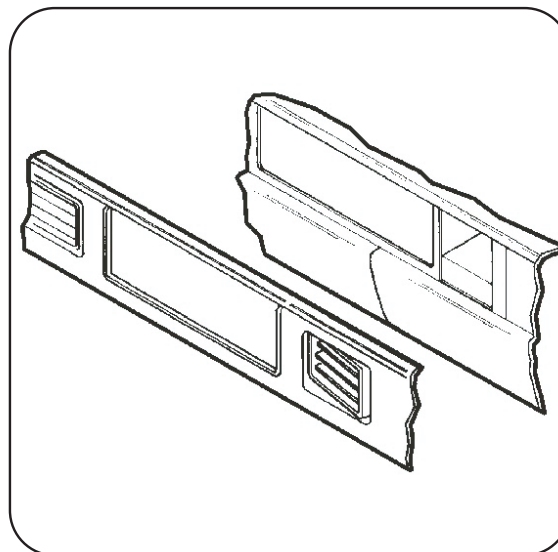

DODGE DAKOTA 1987-96

- 1** Disconnect the negative battery terminal to prevent an accidental short circuit.
- 2** Remove (8) Torx head screws from the instrument trim panel.
- 3** Remove (2) Phillips head screws from lower steering column trim and remove trim.
- 4** Remove (1) Phillips head screw at each side of steering column
- 5** Unclip and remove instrument panel trim.
- 6** Remove (2) 3/8" hex head screws securing the radio.
- 7** Unplug and remove the radio.
- 8** Continue to Kit Assembly.

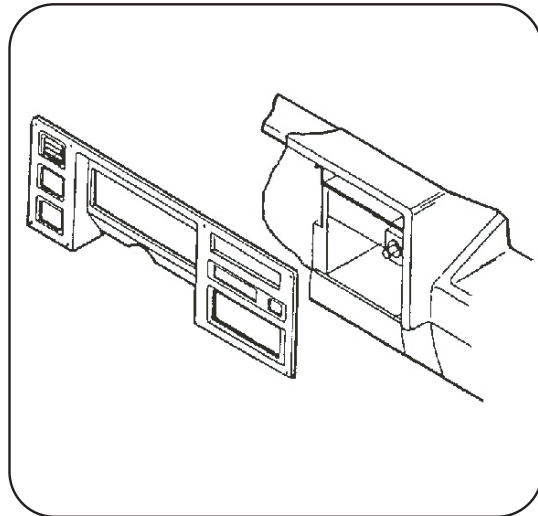

DODGE DAKOTA / DURANGO 1997-2000

- 1** Disconnect the negative battery terminal to prevent an accidental short circuit.
- 2** Unclip and remove instrument trim panel.
- 3** Remove (2) 3/8" hex head screws securing the radio.
- 4** Unplug and remove the radio.
- 5** Continue to Kit Assembly.

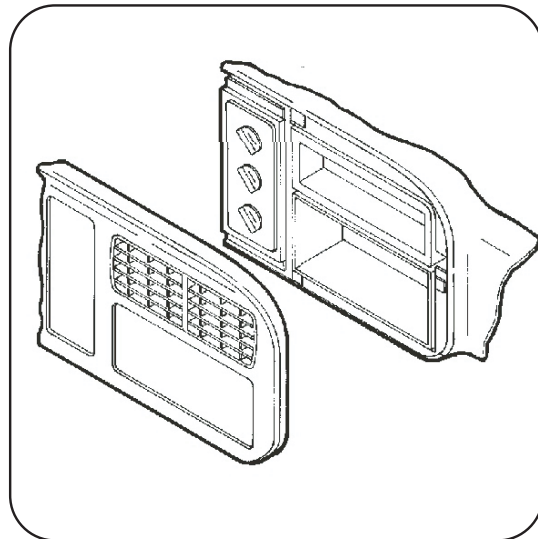

DODGE DAYTONA 1990-93

- 1** Disconnect the negative battery terminal to prevent an accidental short circuit.
- 2** Unclip and remove radio trim panel.
- 3** Remove (1) screw from each side of center console. (This will allow easier access to the screws securing the radio.)
- 4** Remove (1) Phillips head screw at each of steering column
- 5** Unclip and remove instrument panel trim.
- 6** Remove (2) 3/8" hex head screws securing the radio.
- 7** Unplug and remove the radio.
- 8** Continue to Kit Assembly.

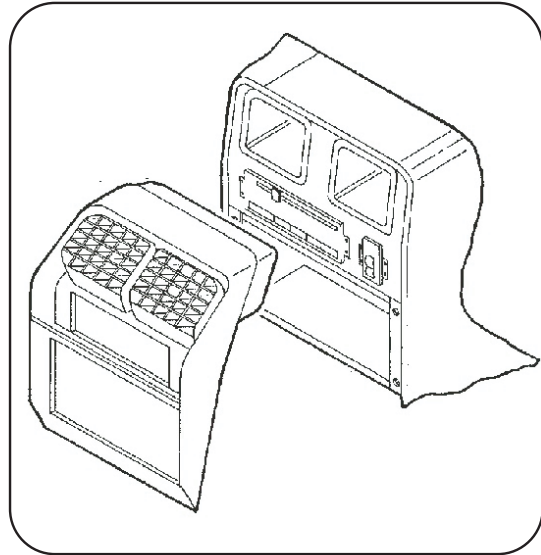

DODGE NEON / PLYMOUTH NEON 1995-99

- 1** Disconnect the negative battery terminal to prevent an accidental short circuit.
- 2** Remove the ashtray.
- 3** Unclip and remove the radio trim panel.
- 4** Remove (2) 3/8" hex head screws securing the radio.
- 5** Unplug and remove the radio.
- 6** Continue to Kit Assembly.

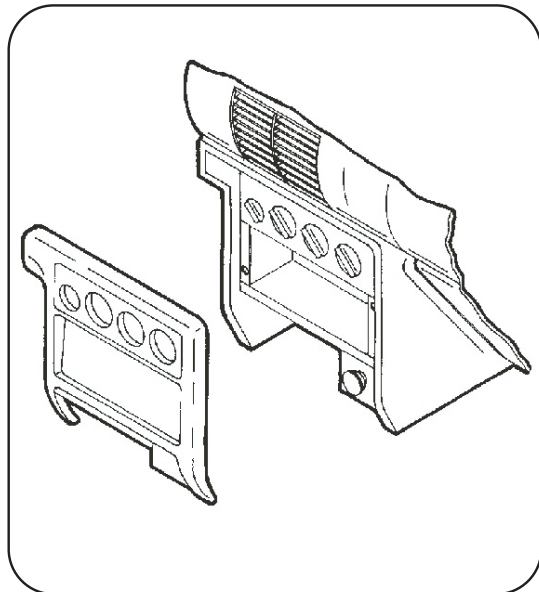



99-6229 DASH DISASSEMBLY

DODGE OMNI / 024 / RAMPAGE 1978-82

PLYMOUTH HORIZON / TC3 1978-82

PLYMOUTH SCAMP 1983-84

- 1 Disconnect the negative battery terminal to prevent an accidental short circuit.
- 2 Remove (7) Phillips head screws from the radio trim panel and remove the panel.
- 3 Remove (2) 3/8" hex head screws securing the radio.
- 4 Unplug and remove the radio.
- 5 Continue to Kit Assembly.

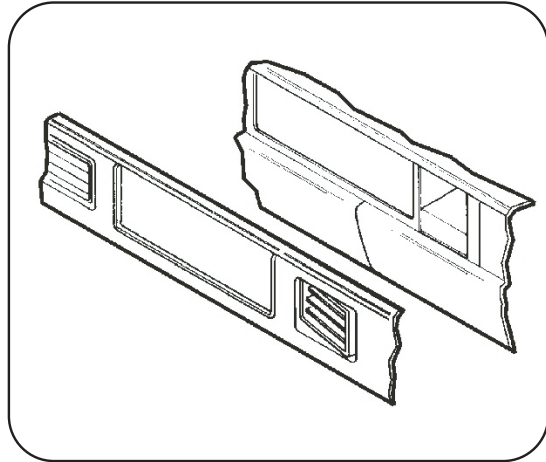

DODGE PICKUP / RAMCHARGER 1974-80

PLYMOUTH TRAILDUSTER 1974-80

- 1 Disconnect the negative battery terminal to prevent an accidental short circuit.
- 2 Remove (4) Phillips head screws from top edge of dash trim panel.
- 3 Remove (7) Phillips head screws from the face of the dash trim panel.
- 4 Remove (3) Phillips head screws from under the dash trim panel.
- 5 Unclip and remove the dash trim panel.
- 6 Remove (2) 3/8" hex head screws securing the radio.
- 7 Unplug and remove the radio.
- 8 Continue to Kit Assembly.

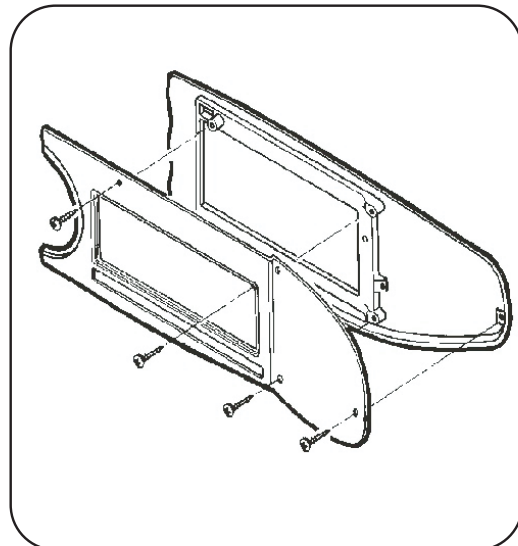

DODGE PICKUP / RAMCHARGER 1981-93**PLYMOUTH TRAILDUSTER 1981**

- 1** Disconnect the negative battery terminal to prevent an accidental short circuit.
- 2** Remove (5) Phillips head screws from the edge of the dash trim panel.
- 3** Remove (1) Phillips head screw from above the radio opening.
- 4** Pry out the bottom edge of the dash trim panel and remove the panel.
- 5** Remove (2) 3/8" hex head screws securing the radio.
- 6** Unplug and remove the radio.
- 7** Continue to Kit Assembly.

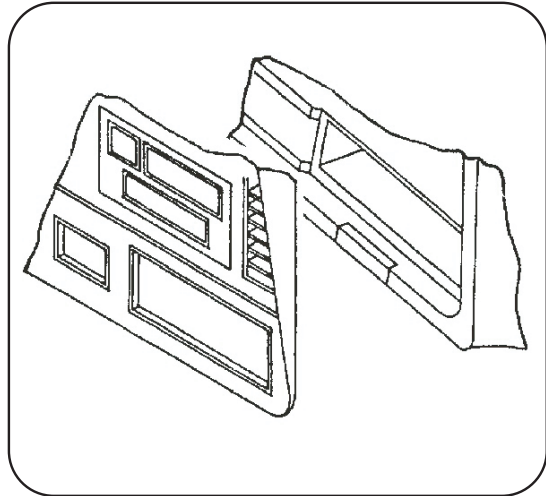
**DODGE RAM 1994-97**

- 1** Disconnect the negative battery terminal to prevent an accidental short circuit.
- 2** Remove the ashtray and (2) Phillips head screws from inside the ashtray cavity to remove the ashtray bracket.
- 3** Open the cup holder and remove (2) Phillips head screws to remove the cup holder assembly.
- 4** Unclip and remove the dash trim panel.
- 5** Remove (2) 3/8" hex head screws securing the radio.
- 6** Unplug and remove the radio.
- 7** Continue to Kit Assembly.

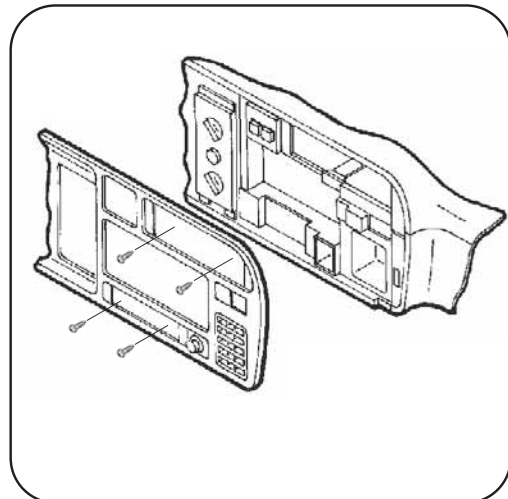



99-6229 DASH DISASSEMBLY

DODGE RAM 1998-2002

(DODGE RAM 2002 - 2500 & 3500 MODELS ONLY)

- 1** Disconnect the negative battery terminal to prevent an accidental short circuit.
- 2** Open door covering power outlet and remove (1) Phillips head screw.
- 3** Unclip and remove the dash trim panel.
- 4** Remove (2) 3/8" hex head screws securing the radio.
- 5** Unplug and remove the radio.
- 6** Continue to Kit Assembly.

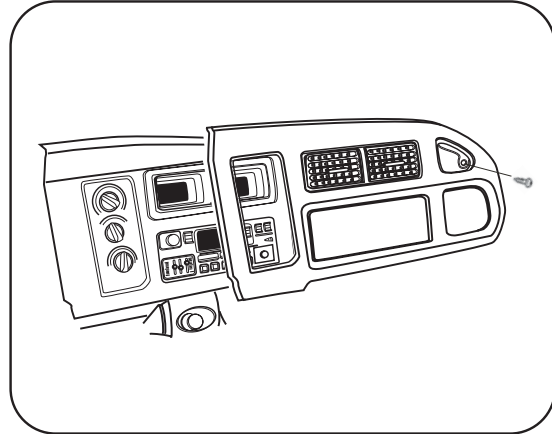

DODGE SHADOW / PLYMOUTH SUNDANCE 1987-94

- 1** Disconnect the negative battery terminal to prevent an accidental short circuit.
- 2** Remove the ashtray.
- 3** Unclip and remove the dash trim panel.
- 4** Remove (1) Phillips head screw from console side trim and remove trim.
- 5** Remove (2) 3/8" hex head screws securing the radio.
- 6** Unplug and remove the radio.
- 7** Continue to Kit Assembly.

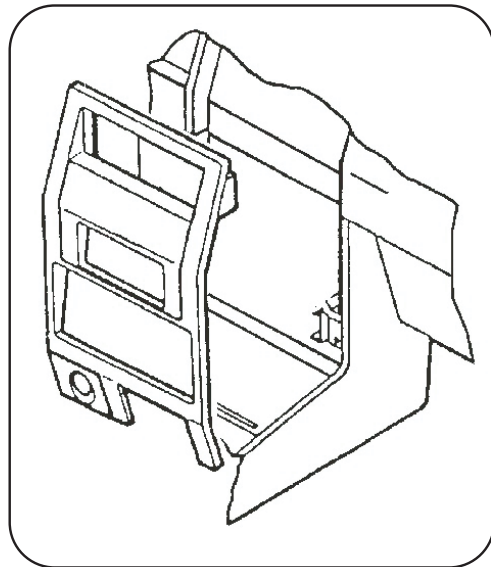

DODGE SPIRIT / PLYMOUTH ACCLAIM 1989-95

- 1** Disconnect the negative battery terminal to prevent an accidental short circuit.
- 2** Unclip and remove the dash trim panel.
- 3** Remove the screws securing the side console trim pieces.
- 4** Move the side console trim pieces enough to gain access to the (2) screws securing the radio.
- 5** Remove (2) 3/8" hex head screws securing the radio.
- 6** Unplug and remove the radio.
- 7** Continue to Kit Assembly.

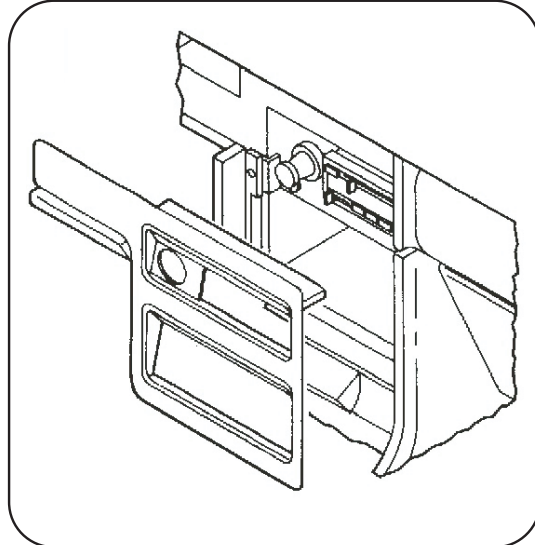

DODGE FULL SIZE VAN 1978-97
PLYMOUTH FULL SIZE VAN 1978-83

- 1** Disconnect the negative battery terminal to prevent an accidental short circuit.
- 2** Open glove box and remove (2) Phillips head screws from inside glove box.
- 3** Remove (5) Phillips head screws from bottom edge of dash trim panel.
- 4** Unclip and remove the dash trim panel
- 5** Remove (2) 3/8" hex head screws securing the radio.
- 6** Unplug and remove the radio.
- 7** Continue to Kit Assembly.

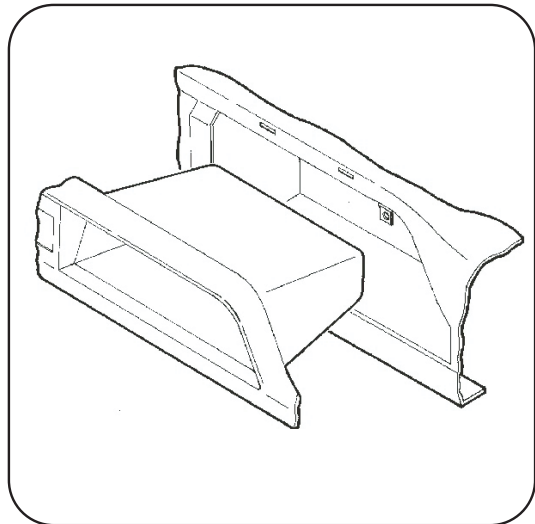

DODGE FULL SIZE VAN 1998-2003

- 1 Disconnect the negative battery terminal to prevent an accidental short circuit.
- 2 Unclip and remove the dash trim panel.
- 3 Remove (2) 3/8" hex head screws securing the radio.
- 4 Unplug and remove the radio.
- 5 Continue to Kit Assembly.

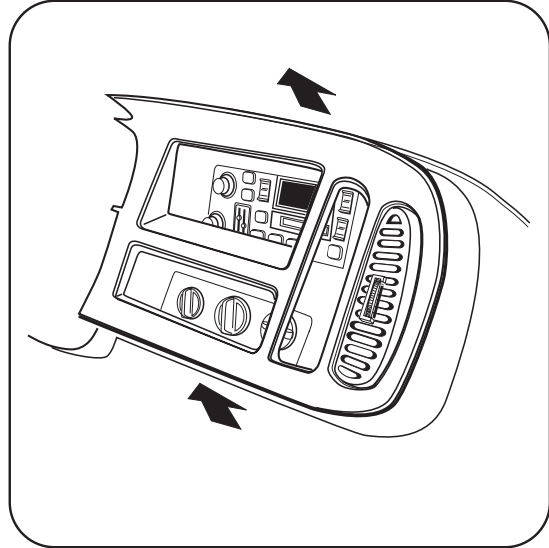

JEEP CHEROKEE 1997-2001

- 1 Disconnect the negative battery terminal to prevent an accidental short circuit.
- 2 Unclip and remove the dash trim panel
- 3 Remove (2) 3/8" hex head screws securing the radio.
- 4 Unplug and remove the radio.
- 5 Continue to Kit Assembly.

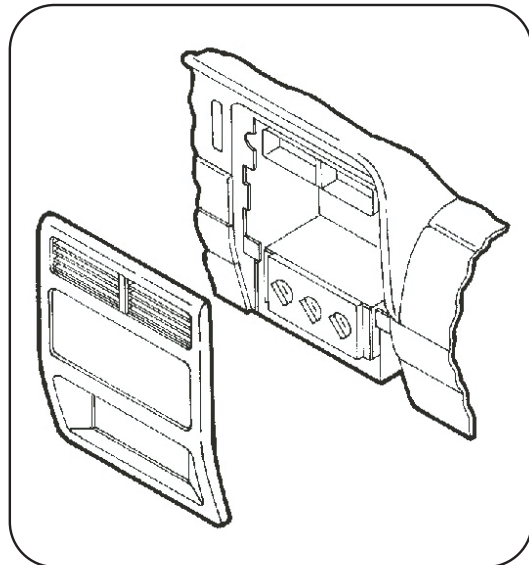

JEEP GRAND CHEROKEE 1996-98

- 1 Disconnect the negative battery terminal to prevent an accidental short circuit.
- 2 Unsnap and remove climate control/wiper control trim panel. Remove (5) Phillips head screws from top edge of radio/instrument cluster trim panel.
- 3 Remove (4) Phillips head screws from bottom edge of radio/instrument cluster trim panel.
- 4 Pry out the bottom edge of the radio/instrument cluster trim panel and remove panel.
- 5 Remove (2) 3/8" hex head screws securing the radio.
- 6 Unplug and remove the radio.
- 7 Continue to Kit Assembly.

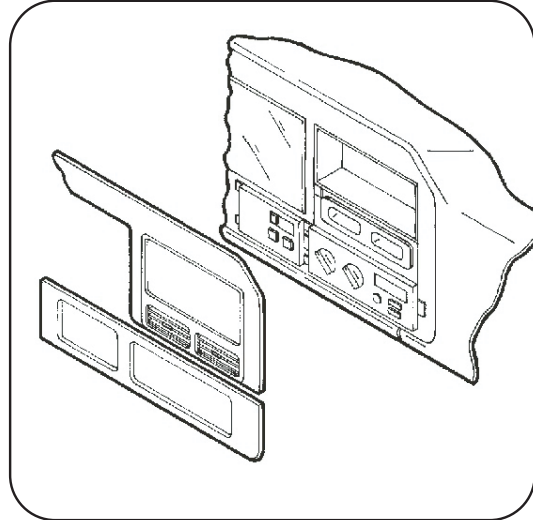
**JEEP WRANGLER 1997-2002**

- 1 Disconnect the negative battery terminal to prevent an accidental short circuit.
- 2 Remove the ashtray and (1) Phillips head screws from inside the ashtray cavity.
- 3 Remove the cover from the top dash near the windshield (defroster).
- 4 Remove (2) Phillips head screws from top of center dash trim panel.
- 5 Pry out the bottom edge of the center dash trim panel and remove panel.
- 6 Remove (2) 3/8" hex head screws securing the radio.
- 7 Unplug and remove the radio.
- 8 Continue to Kit Assembly.

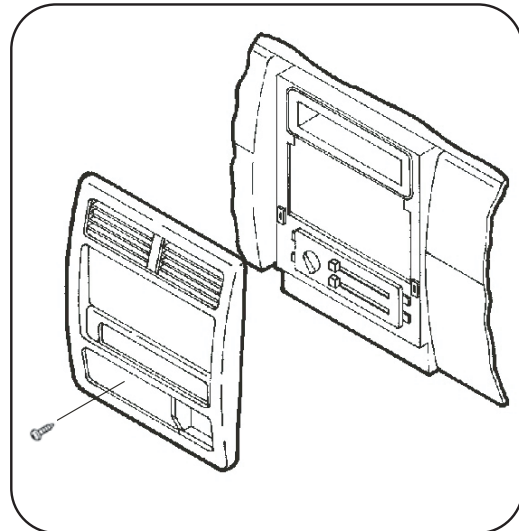

DIN MOUNT PROVISION

- 1** Slide the DIN cage into the Radio Housing and secure by bending the metal locking tabs down. (Figure A)
- 2** Slide the aftermarket radio into the cage and secure. (Figure B)
- 3** Continue to Final Assembly.

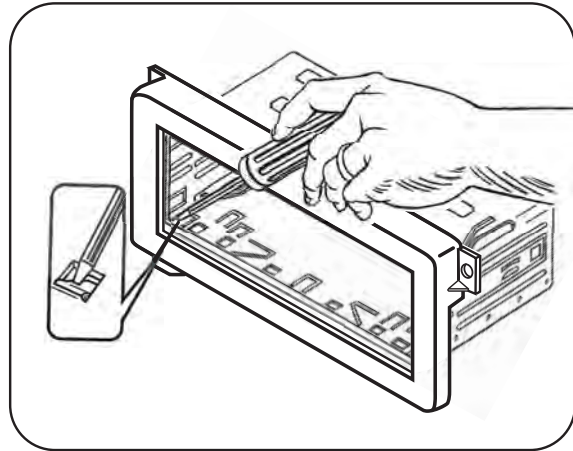
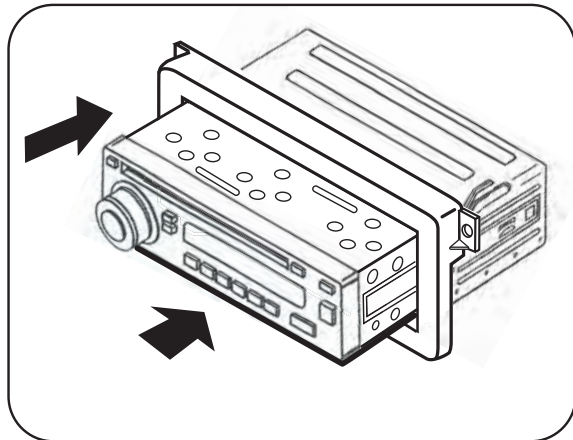
A**B**

FINAL ASSEMBLY

- 1** Locate the factory wiring harness in the dash and make the connection as shown. Metra recommends using the proper mating adapter and making the connections as shown. (Isolate and individually tape off the ends of any unused wires to prevent electrical short circuit.)
- 2** Re-connect the negative battery terminal and test the unit for proper operation.
- 3** Reassemble radio and dash assemblies in reverse order of disassembly.

FINAL WIRING CONNECTIONS

Make wiring connections using the EIA color code chart shown below and the instructions included with the head unit. Metra recommends making connections as shown below; Strip, Splice, Solder, Tape. Isolate and individually tape off ends of any unused wires to prevent electrical short circuit.

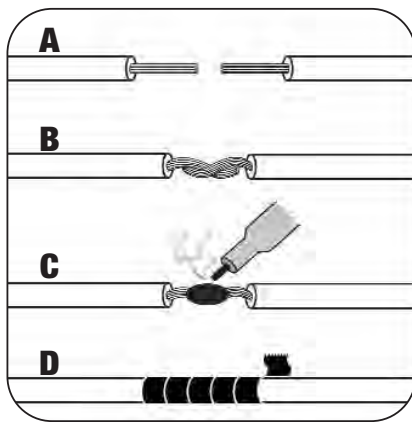

- A) Strip wire ends back 1/2"**
- B) Twist ends together**
- C) Solder**
- D) Tape**

METRA / EIA WIRING CODE

12V Ignition / Acc . . . Red	Right Front (+) Gray
12V Batt / Memory . . Yellow	Right Front (-) Gray / Black
Ground Black*	Left Front (+) White
Power Antenna Blue	Left Front (-) White / Black
Amp Turn-On Blue / White	Right Rear (+) Violet
Amp Ground Black / White	Right Rear (-) Violet / Black
Illumination Orange	Left Rear (+) Green
Dimmer Orange / White	Left Rear (-) Green / Black

***NOTE:** When Black a wire is not present, ground radio to vehicle chassis.
All colors may not be present on all leads due to manufacturer's specifications.



NOTES

99-6229 INSTRUCTIONS



1-800-221-0932



www.metraonline.com

REV. 06/19/06

© COPYRIGHT 2004 METRA ELECTRONICS CORPORATION

INST99-6229