

KIT FEATURES

- ▶ Shaft and DIN unit provisions
- ▶ Various mounting depth alternatives



99-6502 INSTALLATION INSTRUCTIONS

KIT COMPONENTS

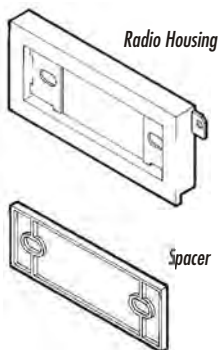

Radio Housing

Spacer

APPLICATIONS

CAR	PAGE
CHRYSLER	
<i>Cirrus 1995-00</i>	1
<i>Sebring (convertible) 1997-00</i>	1
DODGE	
<i>Stratus 1995-00</i>	1
PLYMOUTH	
<i>Breeze 1996-99</i>	1

TOOLS REQUIRED



Phillips screwdriver



Cutting tool



Socket wrench



☎ 1-800-221-0932 💻 www.metraonline.com

© COPYRIGHT 2001 METRA ELECTRONICS CORPORATION

rev. 100103

CHRYSLER Cirrus 1995-00 / DODGE Stratus 1995-00 PLYMOUTH Breeze 1996-99

1

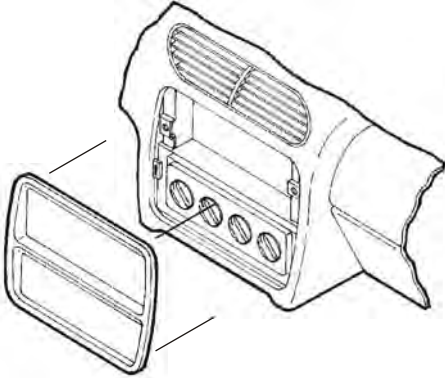

Disconnect the negative battery terminal to prevent an accidental short circuit. Using a flat-blade screwdriver, pry out on the edges of the radio trim bezel. Remove the bezel. Remove (2) 3/8" hex-head screws securing the factory head unit and disconnect the wiring. *Skip to the Installation Instructions for ALL VEHICLES on Page #2.*

CHRYSLER Sebring (convertible) 1996-00

1

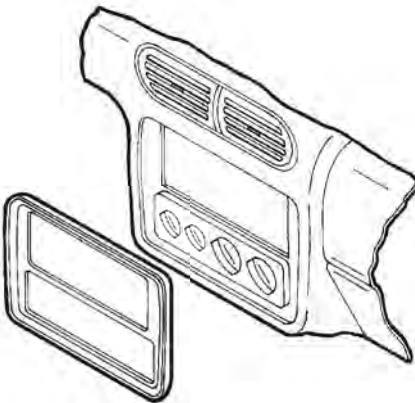

Disconnect the negative battery terminal to prevent an accidental short circuit. Remove the climate control knobs. Remove (1) Phillips screw above and (2) Phillips screws below the climate controls. Unclip the radio trim bezel. Remove (4) screws from the factory head unit, slide the unit out and disconnect the wiring. *Skip to the Installation Instructions for ALL VEHICLES on Page #2.*

ALL VEHICLES

2

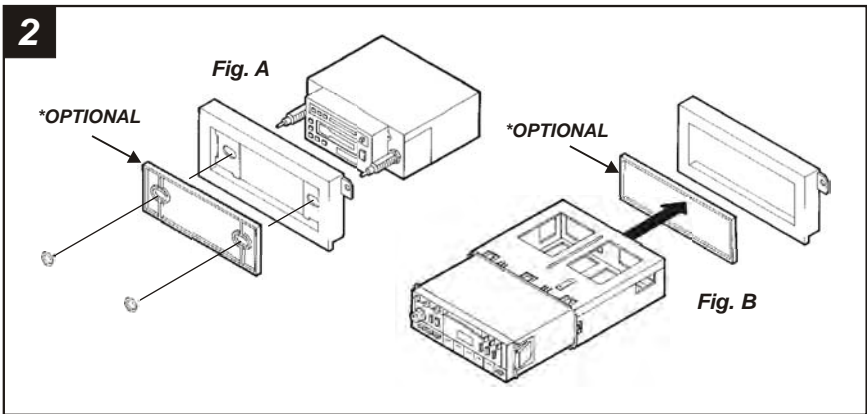

2-SHAFT HEAD UNITS: Attach the **Spacer*** to the **Radio Housing**. Slide the aftermarket head unit into the kit and secure with shaft nuts. (see Fig. A)

DIN HEAD UNITS: Cut and remove the shaft supports from the **Spacer*** and **Radio Housing**. Slide the DIN into the kit and secure by bending the metal locking tabs down. Slide the aftermarket head unit into the cage until secure. (see Fig. B)

3

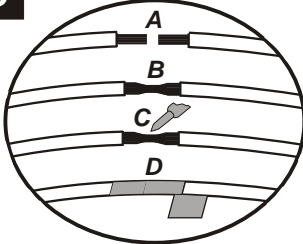

- A) Strip wire ends back 1/2"
- B) Twist ends together
- C) Solder
- D) Tape

Locate the factory wiring harness in the dash. Metra recommends using the proper mating adaptor and making connections as shown. (Isolate and individually tape off the ends of any unused wires to prevent electrical short circuit).

4

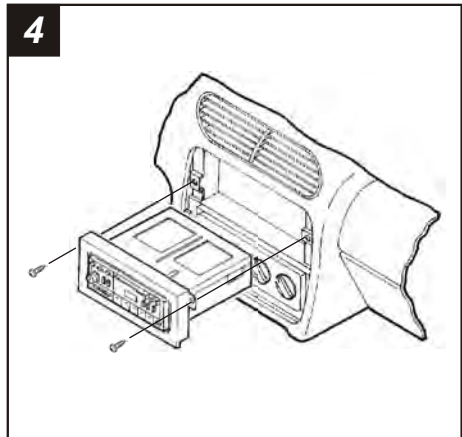

Re-connect the battery terminal and test the unit for proper operation. Mount the head unit/kit assembly to the sub-dash with (2) hex-head screws previously removed in step #1.