



INSTALLATION INSTRUCTIONS FOR PART 99-6505

APPLICATIONS

Chrysler Multi Kit

99-6505

KIT FEATURES

- DIN Head Unit Provision with pocket
- ISO DIN Head Unit Provision with pocket



KIT COMPONENTS

- A) Radio Housing • B) ISO Trim Plate • C) ISO Snap in Brackets

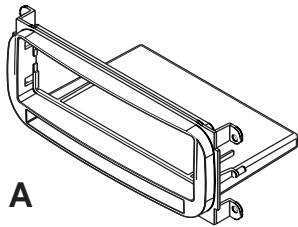

A

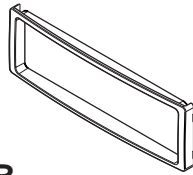

B

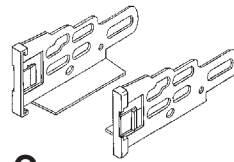

C

TOOLS REQUIRED:

- A) T orx # 20 • B) Phillips Screwdriver • C) Socket Wrench

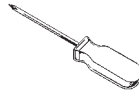
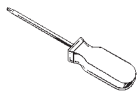

1-800-221-0932



www.metraonline.com

© COPYRIGHT 2004 METRA ELECTRONICS CORPORATION

TABLE OF CONTENTS

Dash Disassembly

<i>Chrysler 300M 1999-2004/Concorde 1998-2004/ Chrysler LHS 1998-2001/ Dodge Intrepid 1998-2004.....</i>	<i>1</i>
<i>Chrysler PT Cruiser. 2001-2005.....</i>	<i>1</i>
<i>Chrysler Sebring/Dodge Stratus 2001-2006.....</i>	<i>2</i>
<i>Chrysler Town & Country/Dodge Caravan 2001-2006.....</i>	<i>2</i>
<i>Dodge Neon 2000-2006/Plymouth Neon 2000-2001.....</i>	<i>3</i>
<i>Dodge Ram 2002-2005.....</i>	<i>3</i>
<i>Jeep Grand Cherokee 1999-2004.....</i>	<i>4</i>
<i>Dodge Dakota 2001-2004/Durango 2001-2003.....</i>	<i>4</i>
<i>Jeep Liberty 2002-2006.....</i>	<i>5</i>
<i>Jeep Wrangler 2003-2006.....</i>	<i>5</i>

Kit Assembly

<i>DIN Head Unit Provision.....</i>	<i>6</i>
<i>ISO DIN Head Unit Provision.....</i>	<i>7</i>

<u>Final Assembly</u>	<i>8</i>
------------------------------------	-----------------

CHRYSLER 300M 1999-2004/CONCORDE 1998-2004

CHRYSLER LHS 1998-2001/DODGE INTREPID 1998-2004

- 1 Disconnect the negative battery terminal to prevent an accidental short circuit.
- 2 Remove the ashtray by pressing down on the inner spring clip. (Concorde only)
- 3 Unclip gear shifter trim panel and slide trim panel toward the rear of the vehicle.
- 4 Unclip dash trim panel and disconnect the wire to the trim panel.
- 5 Remove (4) Phillips head screws securing the radio. Disconnect and remove the radio. Skip to kit assembly page.

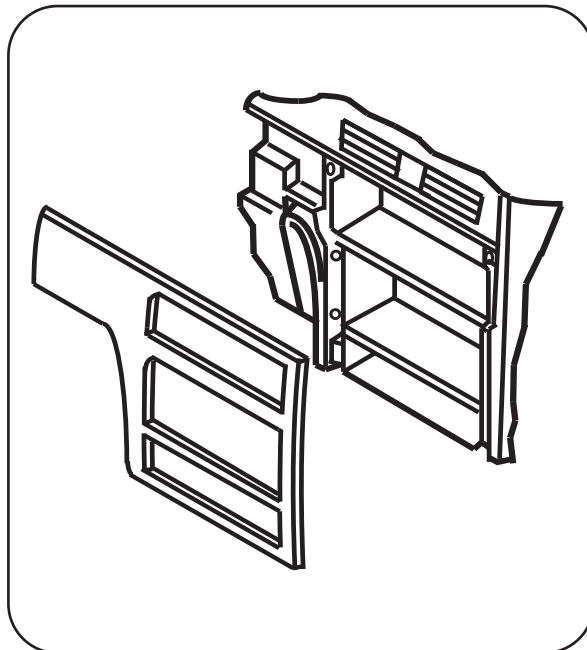

CHRYSLER PT CRUISER 2001-2005

- 1 Disconnect the negative battery terminal to prevent an accidental short circuit.
- 2 Unclip power window control panel. Disconnect and remove panel.
- 3 Pull off climate control knobs.
- 4 Unclip and remove the dash trim panel.
- 5 Remove (4) Phillips head screws securing the radio. Disconnect and remove the radio. Skip to kit assembly page.

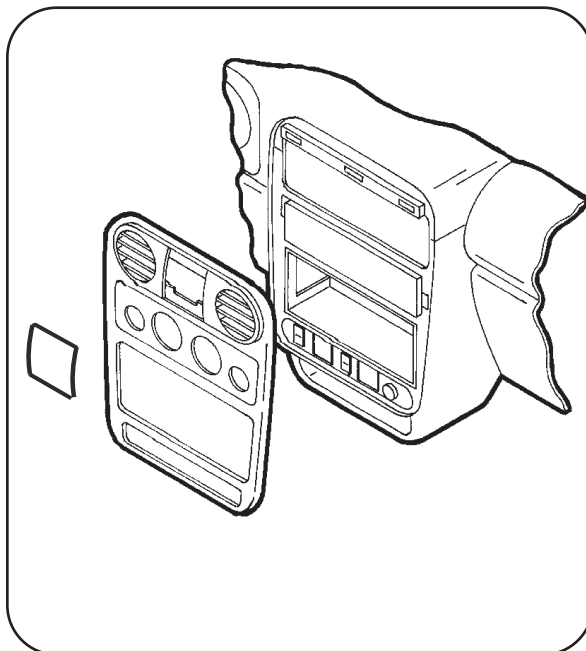

CHRYSLER SEBRING DODGE STRATUS 2001-2006

- 1 Disconnect the negative battery terminal to prevent an accidental short circuit.
- 2 Remove (2) Phillips head screws from under the climate controls.
- 3 Unclip and remove radio trim panel.
- 4 Remove (4) Phillips head screws securing the radio. Disconnect and remove the radio. Skip to kit assembly page.

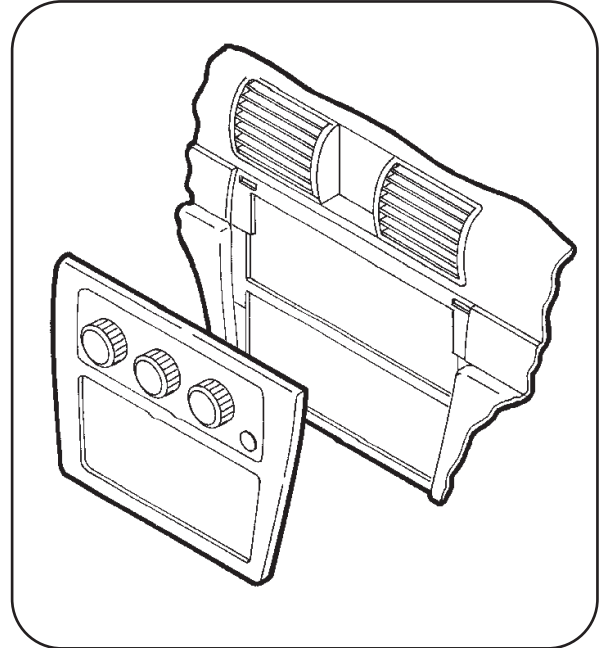

CHRYSLER TOWN & COUNTRY DODGE CARAVAN 2001-2006

- 1 Disconnect the negative battery terminal to prevent an accidental short circuit.
- 2 Open cup holder. Unclip and remove trim above cup holder.
- 3 Remove (2) Phillips head screws from above cup holder.
- 4 Unclip and remove the dash trim panel.
- 5 Remove (4) Phillips head screws securing the radio. Disconnect and remove the radio. Skip to kit assembly page.

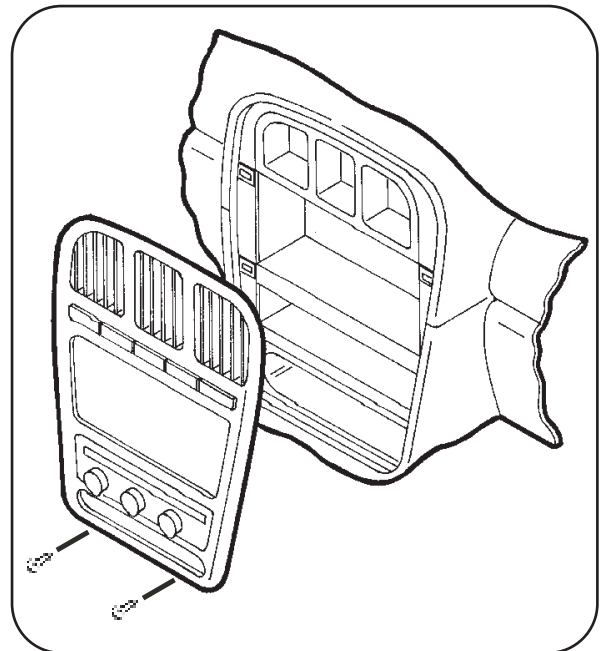

DODGE NEON 2000-2006 PLYMOUTH NEON 2000-2001

- 1 Disconnect the negative battery terminal to prevent an accidental short circuit.
- 2 Pull off climate control knobs.
- 3 Unclip and remove ac/heater vents.
- 4 Remove (1) Phillips head screw from each vent cavity.
- 5 Unclip and remove dash trim panel.
- 6 Remove (4) Phillips head screws securing the radio. Disconnect and remove the radio. Skip to kit assembly page.

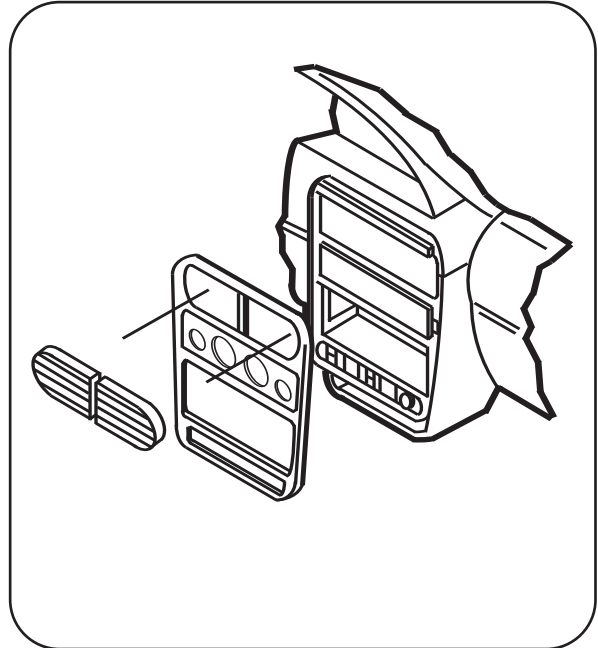

DODGE RAM 2002-2005

- 1 Disconnect the negative battery terminal to prevent an accidental short circuit.
- 2 Unclip the top edge of the trim panel below the steering column. (It is not necessary to completely remove this panel).
- 3 Remove (1) Phillips head screw from below right ac/heater vent.
- 4 Unclip and remove dash trim panel.
- 5 Remove (4) Phillips head screws securing the radio. Disconnect and remove the radio. Skip to kit assembly page.

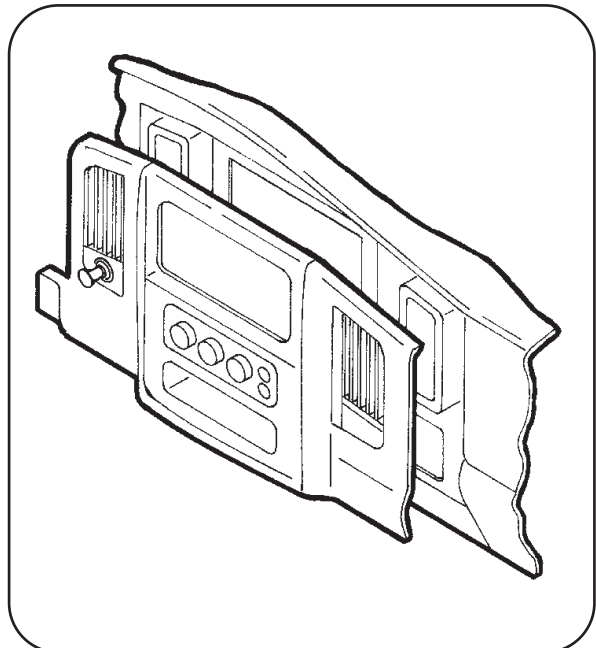

JEEP GRAND CHEROKEE 1999-2004

- 1 Disconnect the negative battery terminal to prevent an accidental short circuit.
- 2 Unclip and remove radio trim panel.
- 3 Remove (4) Phillips head screws securing the radio. Disconnect and remove the radio. Skip to kit assembly page.

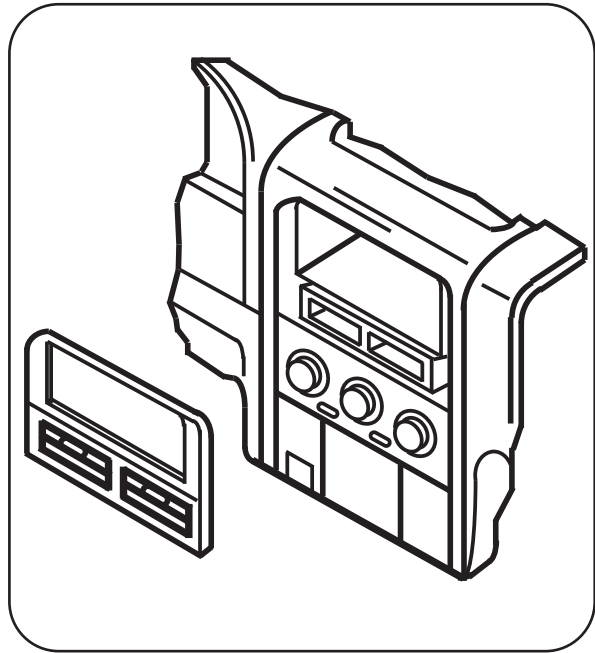

DODGE DAKOTA 2001-2004

DURANGO 2001-2003

- 1 Disconnect the negative battery terminal to prevent an accidental short circuit.
- 2 Remove (3) T-20 Torx screws from the bottom edge of the panel below the steering column and unsnap to remove panel.
- 3 Remove (2) Phillips screws from the instrument cluster panel above gauges.
- 4 Remove (3) T-20 Torx screws from the bottom of the steering column shroud and unsnap and remove the top half of the shroud.

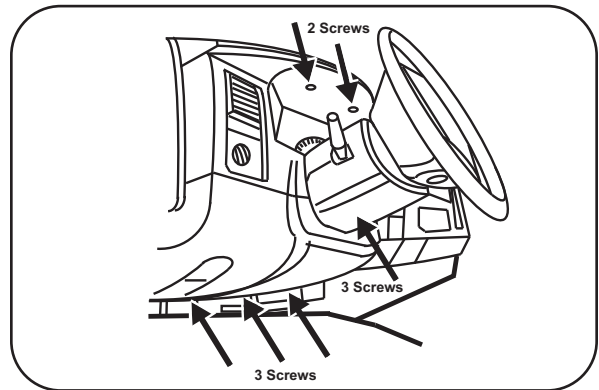

- 5 Unsnap and remove entire panel surrounding radio, a/c controls, and instrument cluster.
- 6 Remove (4) Phillips screws securing radio. Disconnect and remove radio. Skip to kit assembly page.

JEEP LIBERTY 2002-2006

- 1 Disconnect the negative battery terminal to prevent an accidental short circuit.
- 2 Remove ashtray and remove one Phillips screw exposed.
- 3 Unclip and remove radio/ climate control panel.
- 4 Remove (4) Phillips screws securing radio. Disconnect and remove radio. Skip to kit assembly page.

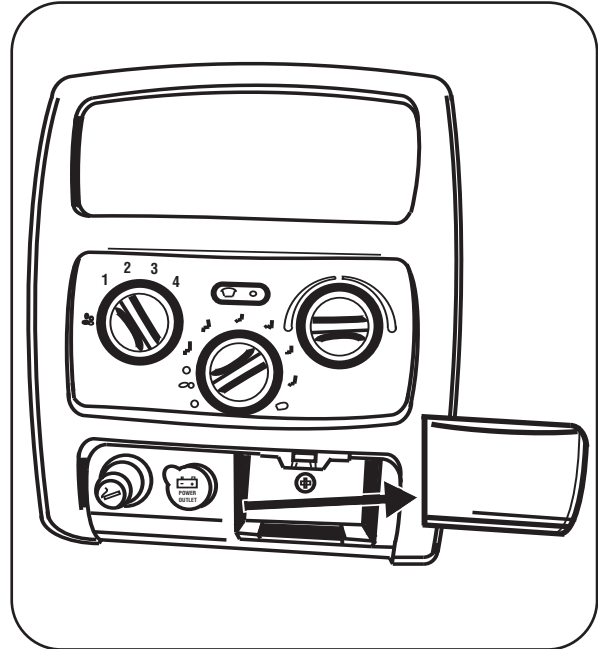

JEEP WRANGLER 2003-2006

- 1 Disconnect the negative battery terminal to prevent an accidental short circuit.
- 2 Unsnap and remove defroster grille panel near windshield.
- 3 Remove two Phillips screws exposed at the top of the center dash panel and unsnap and remove panel.
- 4 Remove glove box door to access one 10mm nut on back of radio.
- 5 Remove (4) Phillips screws securing radio. Disconnect and remove radio. Skip to kit assembly page.

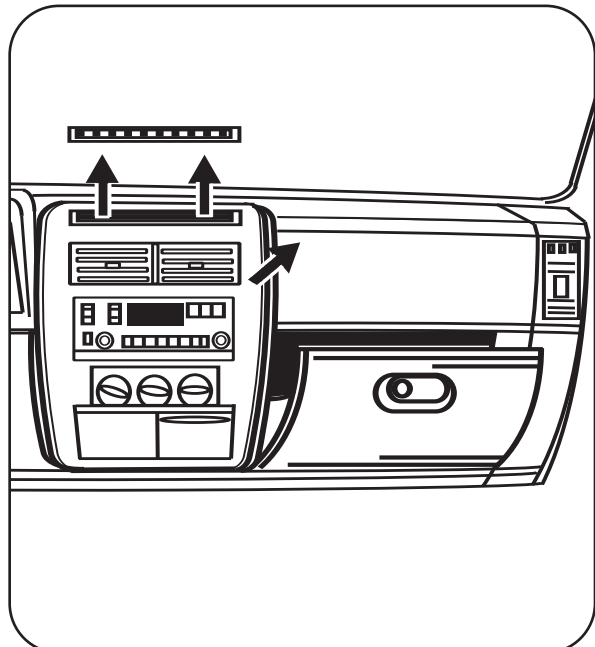

DIN HEAD UNIT PROVISION

- 1** Slide the DIN cage into the Radio Housing and secure by bending the metal locking tabs down. (Figure A)
- 2** Slide the aftermarket head unit into the cage and secure. (Figure B)

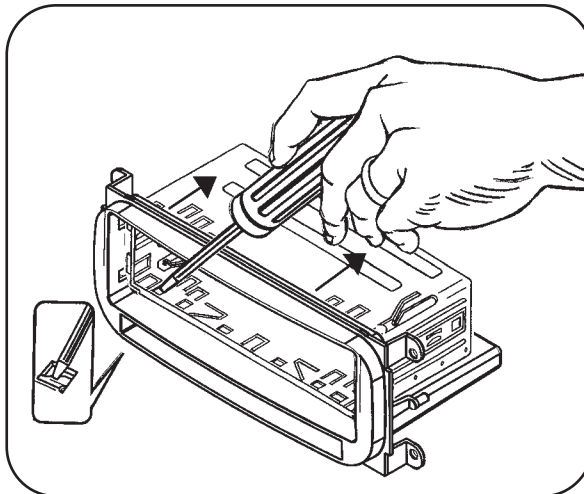
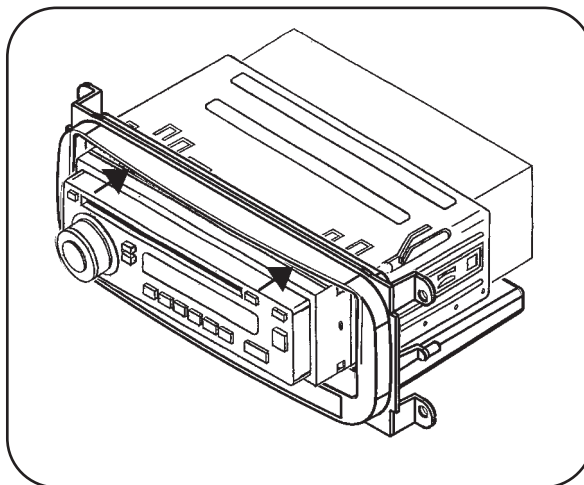
A**B**

ISO DIN HEAD UNIT PROVISION

- 1** Align the holes in the ISO Snap In Brackets with the holes in the head unit and mount the brackets to the head unit with the screws supplied with the unit. (Figure A)
- 2** Slide the head unit/bracket assembly into the radio opening until the side clips engage. (Figure B)
- 3** Snap the ISO Trimplate over the head unit. (Figure B)

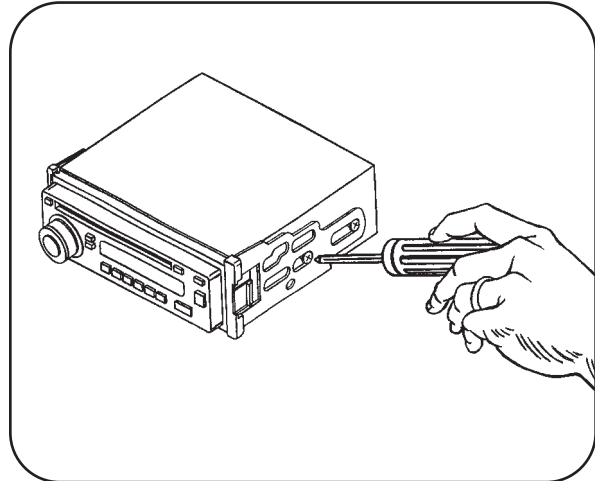
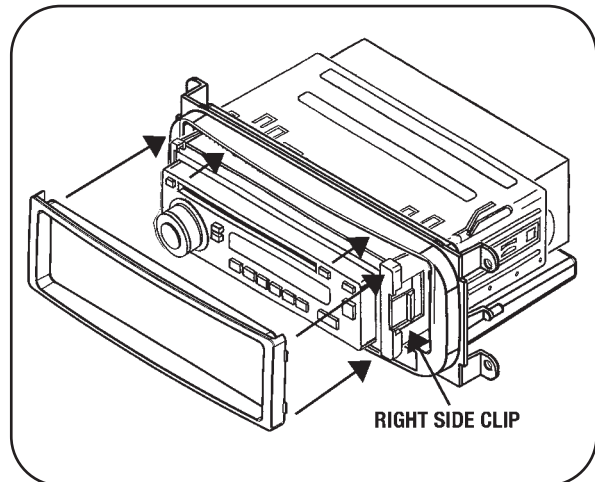
A**B**

FINAL ASSEMBLY

- 1 Locate the factory wiring harness in the dash and make the connection as shown. Metra recommends using the proper mating adapter and making the connections as shown. (Isolate and individually tape off the ends of any unused wires to prevent electrical short circuit.)
- 2 Re-connect the negative battery terminal and test the unit for proper operation.
- 3 Reassemble radio and dash assemblies in reverse order of disassembly.

FINAL WIRING CONNECTIONS

Make wiring connections using the EIA color code chart shown below and the instructions included with the head unit. Metra recommends making connections as shown below; Strip, Splice, Solder, Tape. Isolate and individually tape off ends of any unused wires to prevent electrical short circuit.

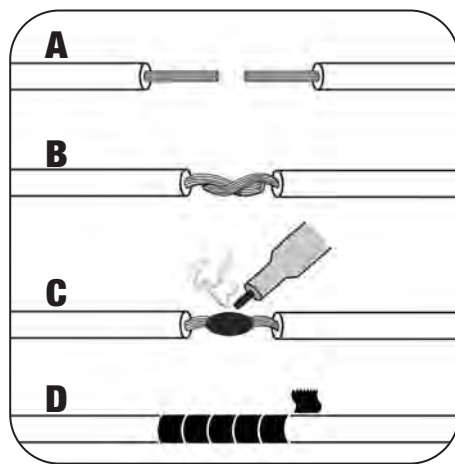

- A) Strip wire ends back 1/2"**
- B) Twist ends together**
- C) Solder**
- D) Tape**

METRA / EIA WIRING CODE

12V Ignition / Acc . . . Red	Right Front (+) Gray
12V Batt / Memory . . Yellow	Right Front (-) Gray / Black
Ground Black*	Left Front (+) White
Power Antenna Blue	Left Front (-) White / Black
Amp Turn-On Blue / White	Right Rear (+) Violet
Amp Ground Black / White	Right Rear (-) Violet / Black
Illumination Orange	Left Rear (+) Green
Dimmer Orange / White	Left Rear (-) Green / Black

***NOTE:** When Black a wire is not present, ground radio to vehicle chassis.

All colors may not be present on all leads due to manufacturer's specifications.

99-6505 INSTRUCTIONS



1-800-221-0932



www.metraonline.com

REV. 03/01/06

© COPYRIGHT 2004 METRA ELECTRONICS CORPORATION

INST99-6505