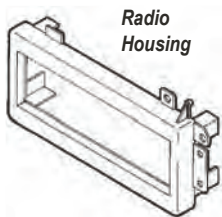

**KIT FEATURES**

- ▶ Recessed  
DIN opening  
for flush mount

**KIT COMPONENTS**Radio  
HousingSupport Spacers  
(Avenger/Sebring)

# 99-6700 AT-510CR AW-510CR DW-6500 INSTALLATION INSTRUCTIONS

**APPLICATIONS**

**CHRYSLER / EAGLE / FORD / JEEP 1974-2003  
(SEE INSIDE FOR SPECIFIC APPLICATIONS)**

**TOOLS REQUIRED**

Phillips screwdriver



Cutting tool



Socket wrench

# TABLE OF CONTENTS

<b><u>CAR</u></b>	<b><u>PAGE</u></b>	<b><u>CAR</u></b>	<b><u>PAGE</u></b>
<b>CHRYSLER</b>		<b>DODGE (cont.)</b>	
Cirrus 1995-00.....	1	Rampage 1978-82.....	11
Concorde 1993-97.....	1	Shadow 1987-93.....	13
Cordoba 1975-78.....	2	Spirit 1989-95.....	14
Cordoba 1979-83.....	2	St. Regis 1979-81.....	2
E-Class 1984-93.....	3	Stratus 1995-00.....	1
Fifth Avenue 1984-93.....	3	Van 1978-03.....	14
Imperial 1982-83.....	2	024 1978-82.....	11
Imperial 1990-94.....	3	400 1982-83.....	3
Laser 1984-89.....	4	600 1983-87.....	3
LeBaron 1976-81.....	5	<b>EAGLE</b>	
LeBaron 1984-85.....	3	Vision 1993-97.....	1
LeBaron 1986-95.....	4	<b>FORD</b>	
LeBaron GTS 1985-94.....	5	Aerostar 1985-91.....	15
LHS 1995-98.....	1	Bronco II 1985-88.....	15
Newport 1977-81.....	2	Crown Victoria 1979-90.....	16
New Yorker 1980-81.....	2	LTD 1979-90.....	16
New Yorker 1983-87.....	3	Ranger (mini) 1985-88.....	15
New Yorker 194-96.....	3	Thunderbird 1985-88.....	16
Prowler 1997-02.....	3	<b>JEEP</b>	
Sebring 1995-00.....	6	Cherokee 1997-01.....	17
Sebring (conv.) 1996-00.....	6	Grand Cherokee 1993-95.....	17
Town & Country 1990-95.....	7	Grand Cherokee 1996-98.....	18
Town & Country 1999-00.....	8	Wrangler 1997-02.....	18
<b>DODGE</b>		<b>LINCOLN</b>	
Aries 1981-89.....	3	Continental 1985-87.....	19
Aspen 1976-80.....	5	Mark VII 1984-89.....	19
Avenger 1995-00.....	6	<b>MERCURY</b>	
Caravan 1984-90.....	7	Cougar 1985-88.....	16
Caravan 1991-95.....	7	Grand Marquis 1979-90.....	16
Caravan 1996-00.....	8	Marquis 1979-90.....	16
Charger 1974-78.....	2	<b>PLYMOUTH</b>	
Charger 1981-83.....	8	Acclaim 1989-95.....	14
Dakota 1987-96.....	9	Breeze 1996-99.....	1
Dakota 1997-00.....	9	Caravelle 1985-87.....	3
Daytona 1984-89.....	4	Fury 1975-78.....	2
Daytona 1990-93.....	10	Gran Fury 1975-85.....	5
Diplomat 1976-89.....	5	Horizon 1978-82.....	11
Durango 1997-00.....	10	Neon 1994-99.....	11
Dynasty 1988-93.....	3	Reliant 1981-89.....	3
Intrepid 1993-97.....	1	Scamp 1983-84.....	11
Lancer 1985-89.....	5	Sundance 1987-94.....	13
Magnum XE 1978-79.....	2	TC3 1978-82.....	11
Mirada 1979-82.....	2	Trailduster 1974-80.....	12
Neon 1994-99.....	11	Trailduster 1981.....	12
Omni 1978-90.....	11	Turismo 1983-87.....	8
Pickup 1974-80.....	12	Van 1978-97.....	14
Pickup 1981-93.....	12	Volare 1976-80.....	5
Ram 1994-01.....	13	Voyager 1984-90.....	7
Ram 2500/3500 2002.....	13	Voyager 1991-95.....	7
Ramcharger 1974-80.....	12	Voyager 1996-00.....	8
Ramcharger 1981-93.....	12		

**CHRYSLER Cirrus 1995-00 / DODGE Stratus 1995-00  
PLYMOUTH Breeze 1996-99**

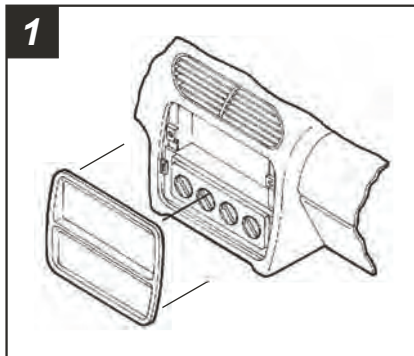

1  
Disconnect the negative battery terminal to prevent an accidental short circuit. Using a flat-blade screwdriver, pry out on the edges of the radio trim bezel. Unclip the bezel and remove. Remove (2) 3/8" hex-head screws securing the factory head unit and disconnect the wiring.

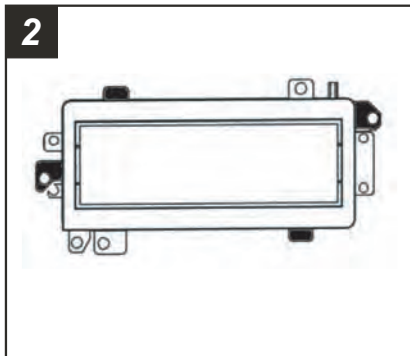

2  
Cut and remove all mounting tabs on the Radio Housing EXCEPT the shaded tabs. Skip to the Installation Instructions for ALL VEHICLES on Page #20.

**CHRYSLER Concorde / LHS 1995-98  
DODGE Intrepid 1993-97 / EAGLE Vision 1993-97**

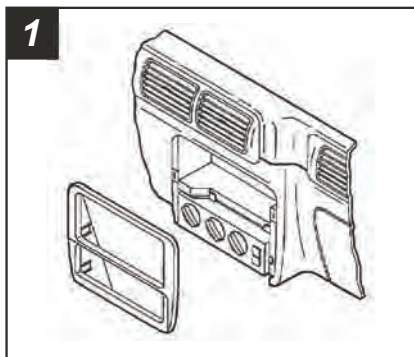

1  
Disconnect the negative battery terminal to prevent an accidental short circuit. Unclip the radio trim bezel and remove. Remove (2) 3/8" hex-head screws securing the factory head unit and disconnect the wiring.

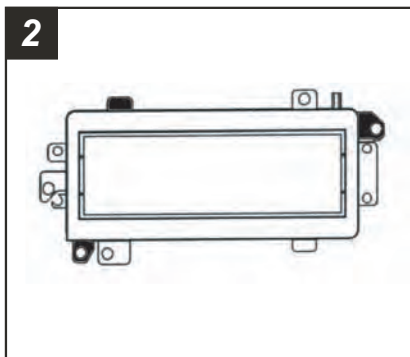

2  
Cut and remove all mounting tabs on the Radio Housing EXCEPT the shaded tabs. Skip to the Installation Instructions for ALL VEHICLES on Page #20.

**CHRYSLER Cordoba 1975-78 / PLYMOUTH Fury 1975-78  
DODGE Charger 1974-78 / Magnum XE 1978-79**

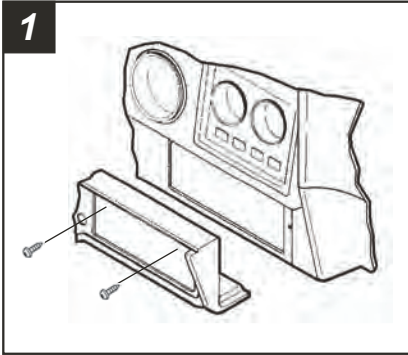

Disconnect the negative battery terminal to prevent an accidental short circuit. Remove (4) Phillips screws from the bottom edge of the radio trim bezel. Remove (2) Phillips screws above the radio opening. Unscrew the retainer ring securing the remote mirror control and remove the bezel. Remove (2) 3/8" hex-head screws securing the factory head unit and disconnect the wiring.

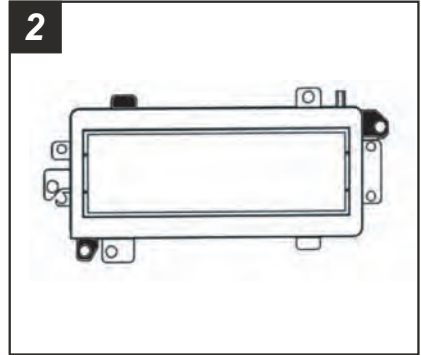

Cut and remove all mounting tabs on the Radio Housing EXCEPT the shaded tabs. Skip to the Installation Instructions for ALL VEHICLES on Page #20.

**CHRYSLER Cordoba 1979-83 / Imperial 1982-83  
Newport 1980-81 / New Yorker 1980-81  
DODGE Mirada 1980-83 / St. Regis 1979-81**

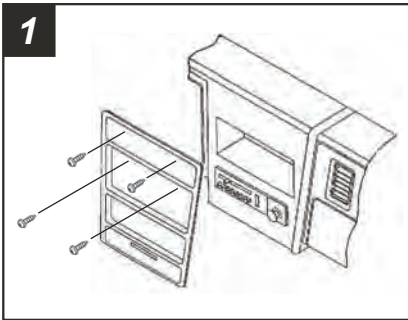

Disconnect the negative battery terminal to prevent an accidental short circuit. Remove (2) Phillips screws above the radio opening. Remove (2) Phillips screws above the climate controls. Unclip the dash trim bezel and remove. Remove (2) 3/8" hex-head screws securing the factory head unit and disconnect the wiring.

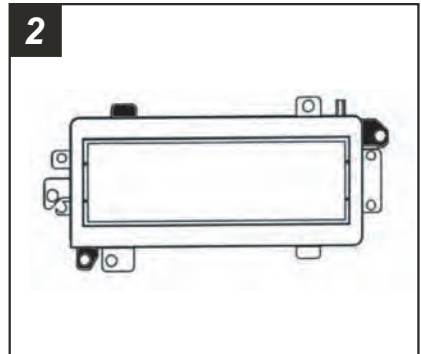

Cut and remove all mounting tabs on the Radio Housing EXCEPT the shaded tabs. Skip to the Installation Instructions for ALL VEHICLES on Page #20.

**CHRYSLER E-Class 1983-84 / LeBaron 1982-85 / New Yorker 1983-87**  
**DODGE Aries 1981-89 / 400 1982-83 / 600 1983-87**  
**PLYMOUTH Caravelle 1985-87 / Reliant 1981-89**

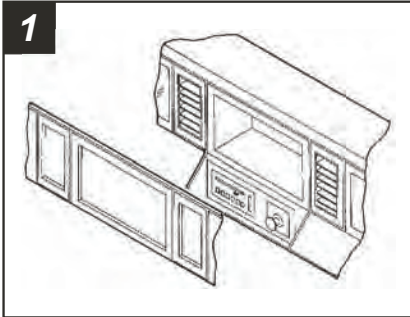

Disconnect the negative battery terminal to prevent an accidental short circuit. Remove (3) Phillips screws from the top edge of the dash trim bezel. Remove (3) Phillips screws from the bottom edge of the dash trim bezel. Unclip the bezel and disconnect the wiring. Remove (2) 3/8" hex-head bolts securing the factory head unit and disconnect the wiring.

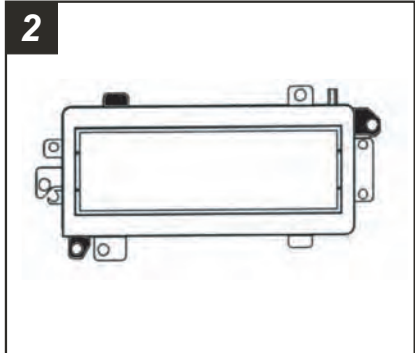

Cut and remove all mounting tabs on the Radio Housing EXCEPT the shaded tabs. Skip to the Installation Instructions for ALL VEHICLES on Page #20.

**CHRYSLER Fifth Avenue 1990-94 / Imperial 1990-94**  
**New Yorker 1988-95**  
**DODGE Dynasty 1988-93**

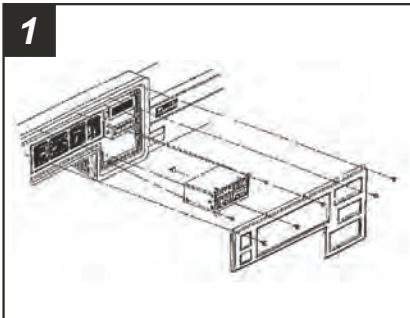

Disconnect the negative battery terminal to prevent an accidental short circuit. Remove (2) Phillips screws above the radio opening. Remove (2) Phillips screws above the climate controls. Unclip the dash trim bezel and remove. Remove (2) 3/8" hex-head screws securing the factory head unit and disconnect the wiring.

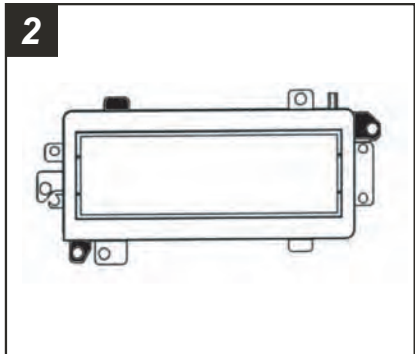

Cut and remove all mounting tabs on the Radio Housing EXCEPT the shaded tabs. Skip to the Installation Instructions for ALL VEHICLES on Page #20.

## CHRYSLER Laser 1984-89 / DODGE Daytona 1984-89

1

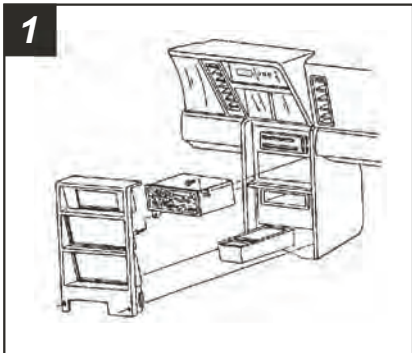

Disconnect the negative battery terminal to prevent an accidental short circuit. Remove (2) Phillips screws from the base of the dash trim bezel. Pull out on the lower edge of the bezel and remove. Remove (2) 3/8" hex-head screws securing the factory head unit and disconnect the wiring.

2

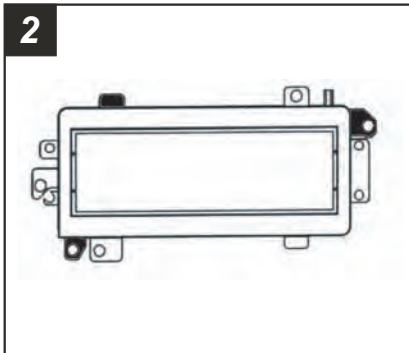

Cut and remove all mounting tabs on the Radio Housing EXCEPT the shaded tabs. Skip to the Installation Instructions for ALL VEHICLES on Page #20.

## CHRYSLER LeBaron 1984-95

1

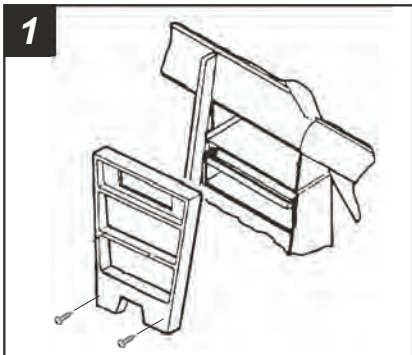

Disconnect the negative battery terminal to prevent an accidental short circuit. Remove (1) Phillips screw from the lower corner of the dash trim bezel. Unclip the bezel and remove. Remove (2) Phillips screws from the right console panel and remove the panel. Remove (2) hex-head screws securing the factory head unit and disconnect the wiring.

2

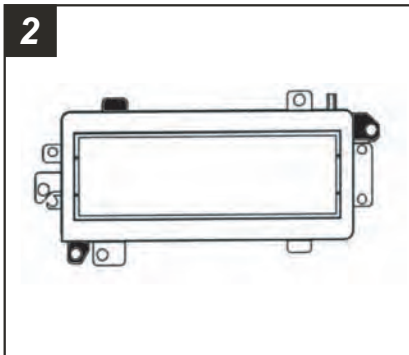

Cut and remove all mounting tabs on the Radio Housing EXCEPT the shaded tabs. Skip to the Installation Instructions for ALL VEHICLES on Page #20.

## **CHRYSLER LeBaron GTS 1985-94** **DODGE Lancer 1985-89**

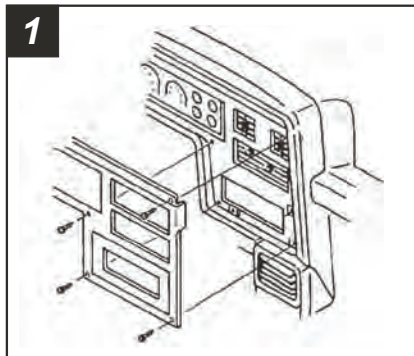

Disconnect the negative battery terminal to prevent an accidental short circuit. Remove (5) torx-head screws from the top of the dash trim bezel. Remove (2) torx-head screws below the radio opening. Remove (1) torx-head screw from the upper-left corner of the radio opening. Remove (4) torx-head screws from the lower-left area of the dash trim bezel. Unclip the bezel and remove. Remove (2) 3/8" hex-head bolts securing the factory head unit and disconnect the wiring.

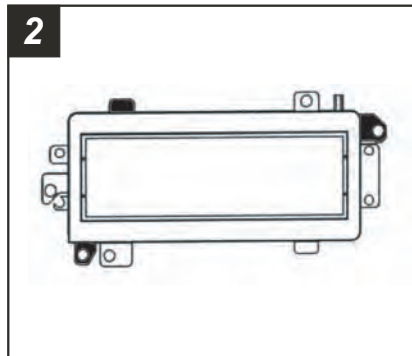

Cut and remove all mounting tabs on the Radio Housing EXCEPT the shaded tabs. Skip to the Installation Instructions for ALL VEHICLES on Page #20.

## **CHRYSLER LeBaron 1976-81** **DODGE Diplomat 1976-89 / Aspen 1976-80** **PLYMOUTH Gran Fury 1975-85 / Volare 1976-80**

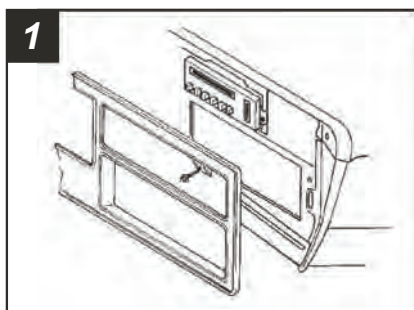

Disconnect the negative battery terminal to prevent an accidental short circuit. Remove (4) Phillips screws from the top of the dash trim bezel. Remove (4) Phillips screws from the bottom of the dash trim bezel. Remove (2) 3/8" hex-head screws securing the factory head unit and disconnect the wiring.

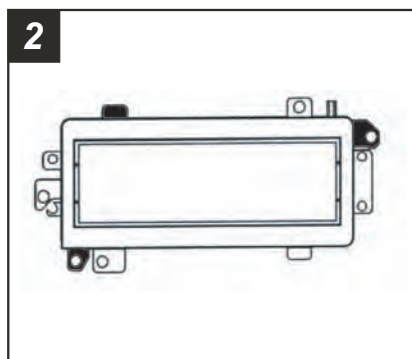

Cut and remove all mounting tabs on the Radio Housing EXCEPT the shaded tabs. Skip to the Installation Instructions for ALL VEHICLES on Page #20.

## CHRYSLER Sebring / DODGE Avenger 1995-00

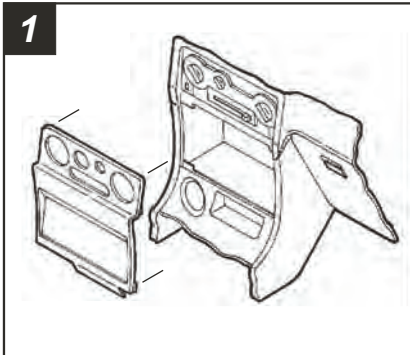

Disconnect the negative battery terminal to prevent an accidental short circuit. Unclip the radio trim bezel and remove. Remove (2) #10 Phillips screws securing the factory head unit and disconnect the wiring.

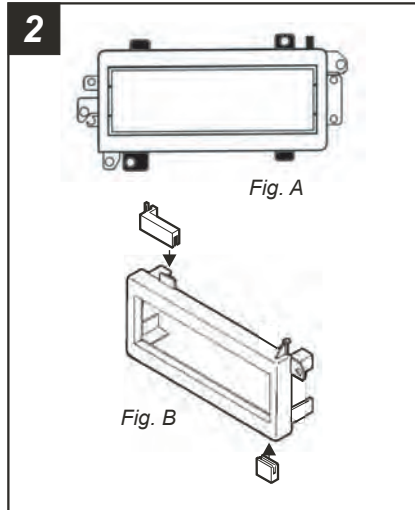

Cut and remove all mounting tabs on the Radio Housing EXCEPT the shaded tabs. Skip to the Installation Instructions for ALL VEHICLES on Page #20.

## CHRYSLER Sebring (convertible) 1995-00

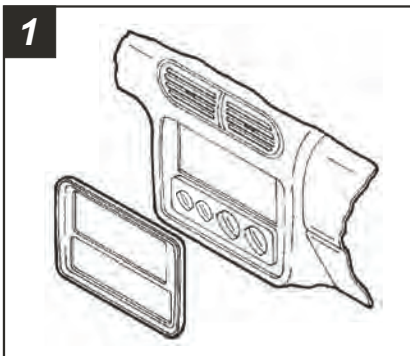

Disconnect the negative battery terminal to prevent an accidental short circuit. Unclip the radio trim bezel and remove. Remove (2) 3/8" hex-head screws securing the factory head unit and disconnect the wiring.

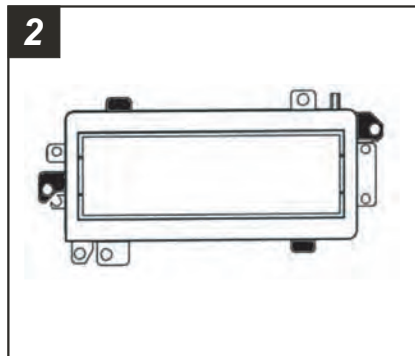

Cut and remove all mounting tabs on the Radio Housing EXCEPT the shaded tabs. Skip to the Installation Instructions for ALL VEHICLES on Page #20.



# CHRYSLER Town & Country 1990-95 DODGE Caravan 1984-90 / PLYMOUTH Voyager 1984-90

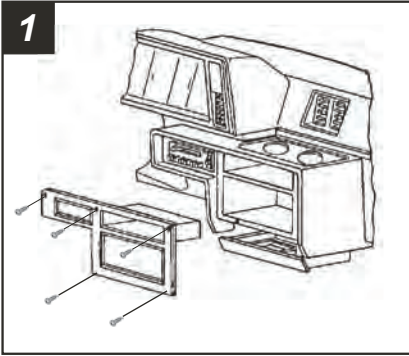

1  
Disconnect the negative battery terminal to prevent an accidental short circuit. Reach behind the ashtray and release the rear tab on the ashtray housing. Remove (2) screws from the bottom edge of the dash trim bezel. Remove (3) screws from the top edge of the dash trim bezel. Unsnap the left edge of the bezel and remove. Remove (2) 3/8" hex-head screws securing the factory head unit and disconnect the wiring.

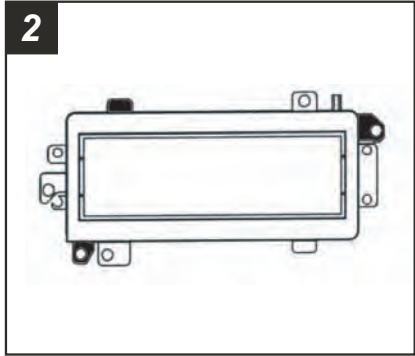

2  
Cut and remove all mounting tabs on the Radio Housing EXCEPT the shaded tabs. Skip to the Installation Instructions for ALL VEHICLES on Page #20.

# DODGE Caravan / PLYMOUTH Voyager 1991-95

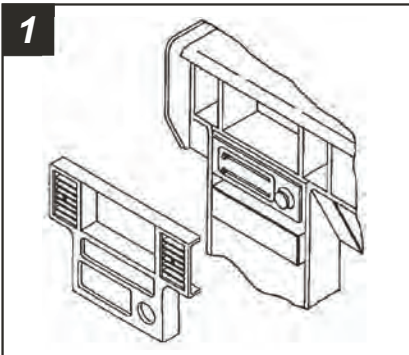

1  
Disconnect the negative battery terminal to prevent an accidental short circuit. Remove the cigarette lighter. Using a panel removal tool, pry out on the dash trim bezel and remove. Remove (2) 3/8" bolts securing the factory head unit and disconnect the wiring.

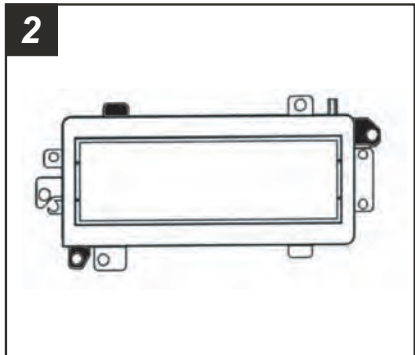

2  
Cut and remove all mounting tabs on the Radio Housing EXCEPT the shaded tabs. Skip to the Installation Instructions for ALL VEHICLES on Page #20.

**DODGE Caravan 1996-00**  
**CHRYSLER Town & Country / PLYMOUTH Voyager 1996-00**

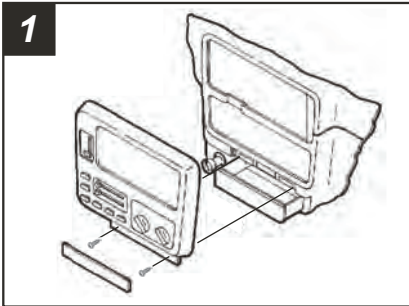

1  
Disconnect the negative battery terminal to prevent an accidental short circuit. Pull the ashtray forward. Unsnap the plastic trim piece located below the radio trim bezel and remove (2) Phillips screws exposed. Remove (2) Phillips screws above the radio opening. Unclip the dash trim bezel, disconnect the climate control wiring and remove the bezel. Remove (2) 3/8" hex-head screws securing the factory head unit and disconnect the wiring.

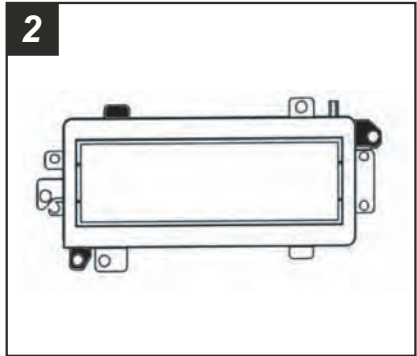

2  
Cut and remove all mounting tabs on the Radio Housing EXCEPT the shaded tabs. Skip to the Installation Instructions for ALL VEHICLES on Page #20.

**DODGE Charger / PLYMOUTH Turismo 1983-87**

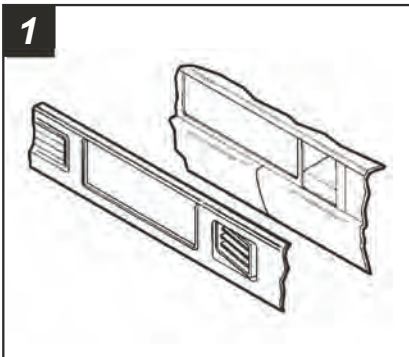

1  
Disconnect the negative battery terminal to prevent an accidental short circuit. Unclip the radio trim bezel and remove. Remove (2) 3/8" hex-head screws securing the factory head unit and disconnect the wiring.

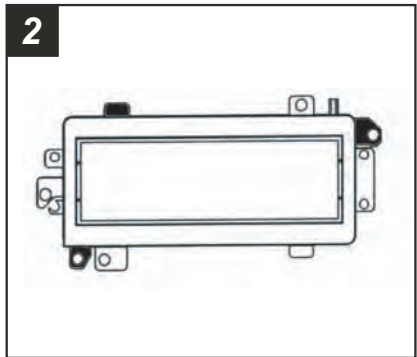

2  
Cut and remove all mounting tabs on the Radio Housing EXCEPT the shaded tabs. Skip to the Installation Instructions for ALL VEHICLES on Page #20.

## DODGE Dakota 1987-96

1

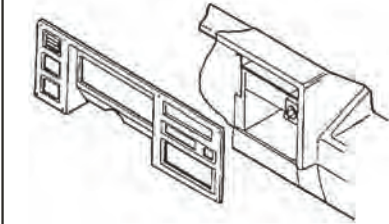

Disconnect the negative battery terminal to prevent an accidental short circuit. Remove (8) torx-head screws from the dash trim bezel. Remove (2) Phillips screws from the lower steering column trim and remove. Remove (1) Phillips screw from each side of the steering column. Unclip the dash trim bezel and remove. Remove (2) Phillips screws securing the factory head unit and disconnect the wiring.

2

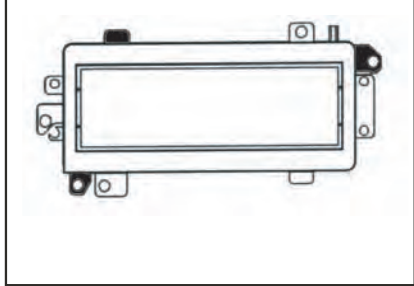

Cut and remove all mounting tabs on the Radio Housing EXCEPT the shaded tabs. Skip to the Installation Instructions for ALL VEHICLES on Page #20.

## DODGE Dakota 1997-00

1

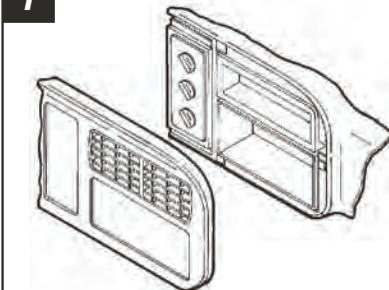

Disconnect the negative battery terminal to prevent an accidental short circuit. Unclip the entire dash trim bezel. Remove (2) 3/8" hex-head screws securing the factory head unit and disconnect the wiring.

2

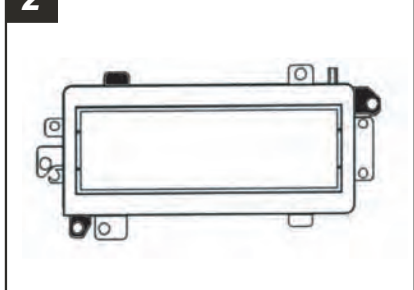

Cut and remove all mounting tabs on the Radio Housing EXCEPT the shaded tabs. Skip to the Installation Instructions for ALL VEHICLES on Page #20.

## DODGE Daytona 1990-93

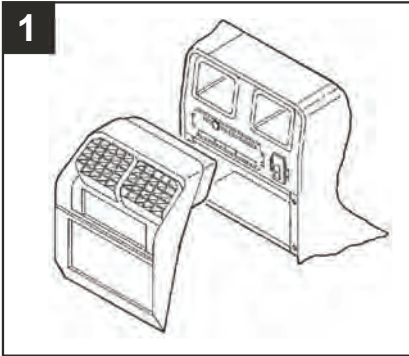

1  
Disconnect the negative battery terminal to prevent an accidental short circuit. Pull out on the dash trim bezel and remove. Remove (2) screws from each side of the lower console (this will allow easier radio removal). Remove (2) screws securing the factory head unit and disconnect the wiring.

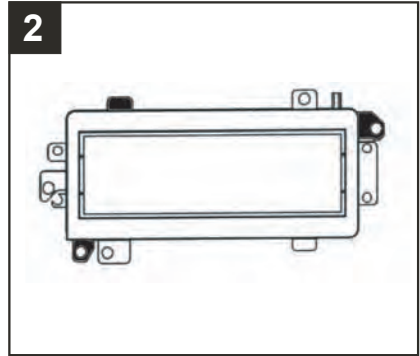

2  
Cut and remove all mounting tabs on the Radio Housing EXCEPT the shaded tabs. Skip to the Installation Instructions for ALL VEHICLES on Page #20.

## DODGE Durango 1997-00

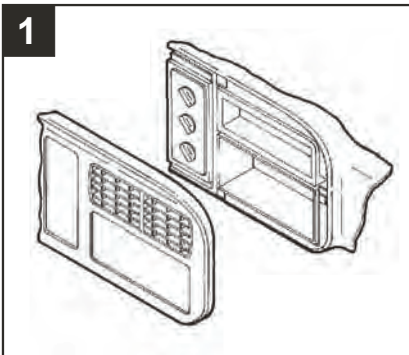

1  
Disconnect the negative battery terminal to prevent an accidental short circuit. Unclip the entire dash trim bezel. Remove (2) 3/8" hex-head screws securing the factory head unit and disconnect the wiring.

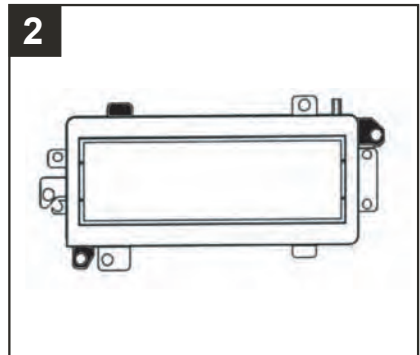

2  
Cut and remove all mounting tabs on the Radio Housing EXCEPT the shaded tabs. Skip to the Installation Instructions for ALL VEHICLES on Page #20.

## DODGE Neon 1994-99 / PLYMOUTH Neon 1994-99

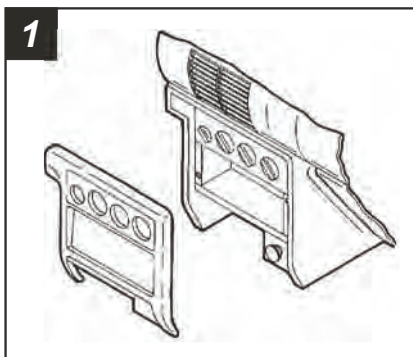

1  
Disconnect the negative battery terminal to prevent an accidental short circuit. Remove the ashtray. Unclip the radio trim bezel and remove. Remove (2) 3/8" hex-head screws securing the factory head unit and disconnect the wiring.

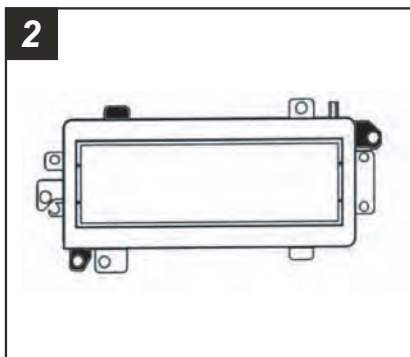

2  
Cut and remove all mounting tabs on the Radio Housing EXCEPT the shaded tabs. Skip to the Installation Instructions for ALL VEHICLES on Page #20.

## DODGE Omni / 024 / Rampage 1978-82 PLYMOUTH Horizon / TC3 1978-82 Scamp 1983-84

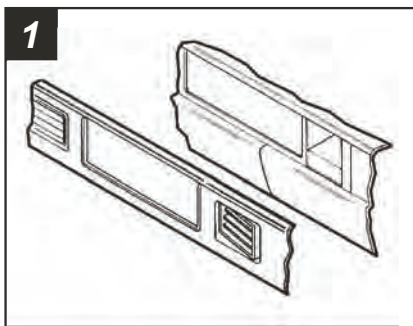

1  
Disconnect the negative battery terminal to prevent an accidental short circuit. Remove (7) Phillips screws from the dash trim bezel and remove the bezel. Remove (2) 3/8" hex-head screws securing the factory head unit and disconnect the wiring.

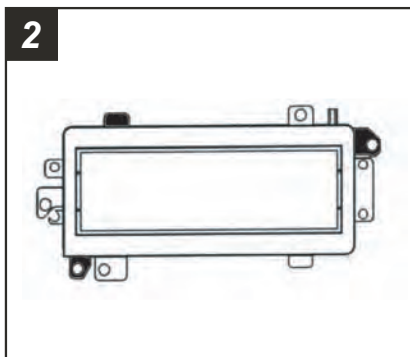

2  
Cut and remove all mounting tabs on the Radio Housing EXCEPT the shaded tabs. Skip to the Installation Instructions for ALL VEHICLES on Page #20.

## DODGE Pickup / Ramcharger 1974-80 PLYMOUTH Trailduster 1974-80

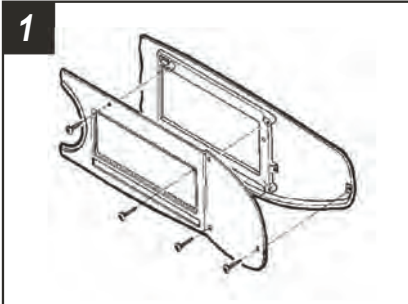

Disconnect the negative battery terminal to prevent an accidental short circuit. Remove (4) Phillips screws from the top edge of the dash trim bezel. Remove (7) Phillips screws from the face of the dash trim bezel. Remove (3) Phillips screws under the dash trim bezel. Unclip the bezel and remove. Remove (2) 3/8" hex-head screws securing the factory head unit and disconnect the wiring.

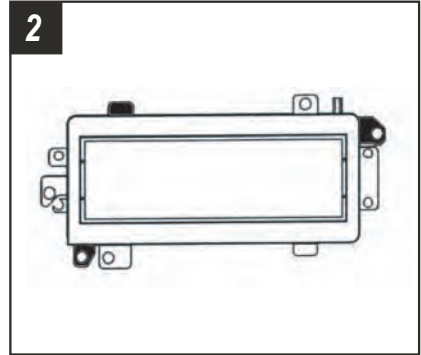

Cut and remove all mounting tabs on the Radio Housing EXCEPT the shaded tabs. Skip to the Installation Instructions for ALL VEHICLES on Page#20.

## DODGE Pickup / Ramcharger 1981-93 PLYMOUTH Trailduster 1981

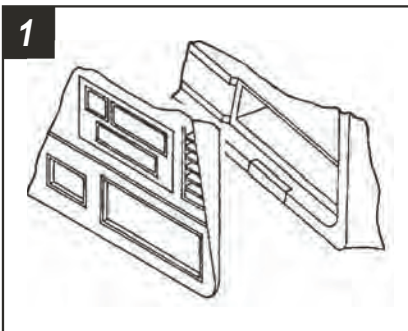

Disconnect the negative battery terminal to prevent an accidental short circuit. Remove (5) Phillips screws from the edge of the dash trim bezel. Remove (1) Phillips screw above the radio opening. Pry out on the bottom edge of the bezel and remove. Remove (2) 3/8" hex-head screws securing the factory head unit and disconnect the wiring.

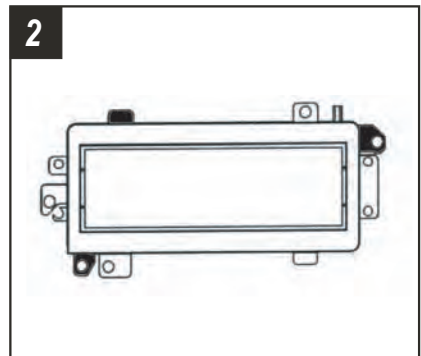

Cut and remove all mounting tabs on the Radio Housing EXCEPT the shaded tabs. Skip to the Installation Instructions for ALL VEHICLES on Page#20.

## DODGE Ram 1994-01, Ram 2500/3500 2002

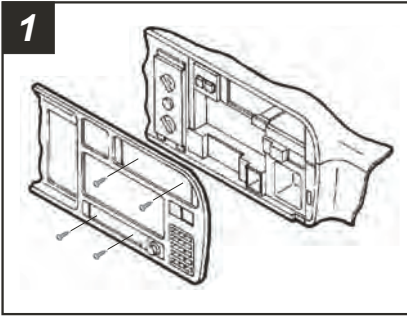

Disconnect the negative battery terminal to prevent an accidental short circuit. Remove the ashtray. Remove (2) Phillips screws exposed in the ashtray cavity and remove the ashtray bracket. Remove the cupholder. Remove (2) Phillips screws exposed in the cupholder cavity and remove the cupholder bracket. Unclip the dash trim bezel, pull the bezel over the steering column and remove. Remove (2) 3/8" hex-head screws securing the factory head unit and disconnect the wiring.

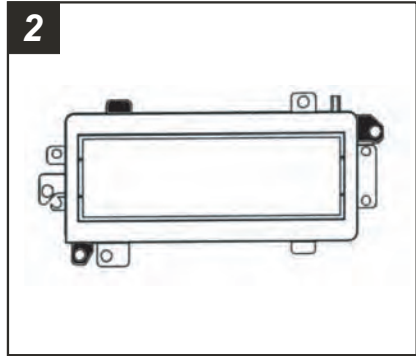

Cut and remove all mounting tabs on the Radio Housing EXCEPT the shaded tabs. Skip to the Installation Instructions for ALL VEHICLES on Page #20.

## DODGE Shadow / PLYMOUTH Sundance 1987-94

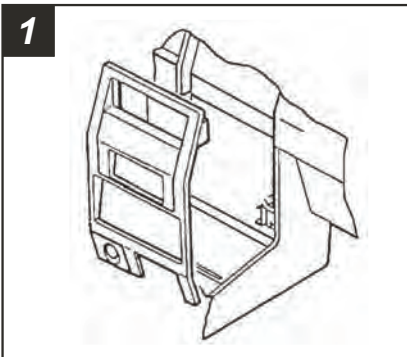

Disconnect the negative battery terminal to prevent an accidental short circuit. Remove the ashtray. Unclip the dash trim bezel and remove. Remove (1) Phillips screw from the console side trim and remove. Remove (2) 3/8" hex-head bolts securing the factory head unit and disconnect the wiring.

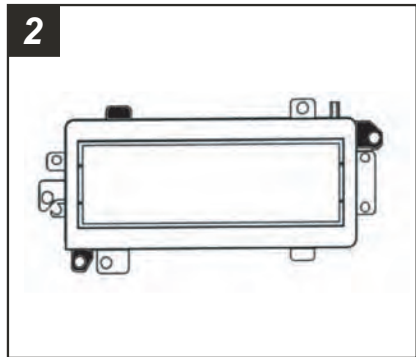

Cut and remove all mounting tabs on the Radio Housing EXCEPT the shaded tabs. Skip to the Installation Instructions for ALL VEHICLES on Page #20.

## DODGE Spirit / PLYMOUTH Acclaim 1989-95

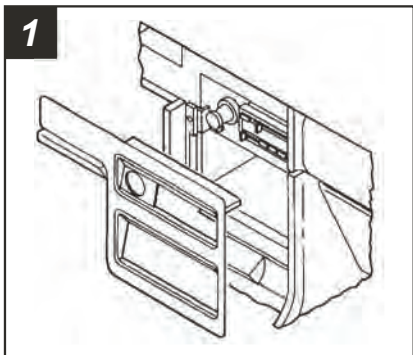

Disconnect the negative battery terminal to prevent an accidental short circuit. Unclip the dash trim bezel and remove. Remove the screws securing the side console trim pieces. Pull the right trim piece out and remove (1) hex-head bolt exposed. Remove (1) hex-head bolt securing the bottom-left corner of the factory head unit and disconnect the wiring.

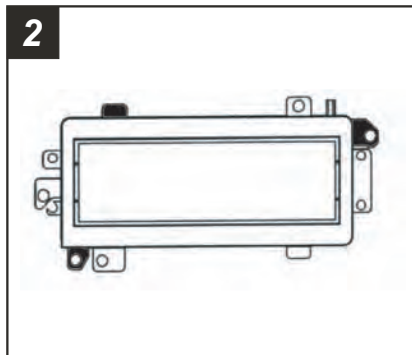

Cut and remove all mounting tabs on the Radio Housing EXCEPT the shaded tabs. Skip to the Installation Instructions for ALL VEHICLES on Page #20.

## DODGE Van / PLYMOUTH Van 1978-03

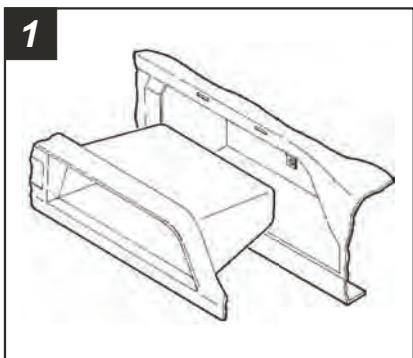

Disconnect the negative battery terminal to prevent an accidental short circuit. Open the glove box and remove (2) Phillips screws exposed. Remove (5) Phillips screws from the bottom of the dash trim bezel. Unclip the top edge of the bezel and remove. Remove (2) 3/8" hex-head screws securing the factory head unit and disconnect the wiring.

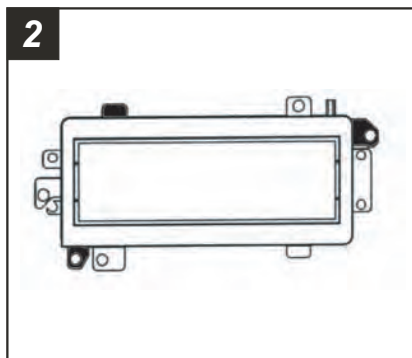

Cut and remove all mounting tabs on the Radio Housing EXCEPT the shaded tabs. Skip to the Installation Instructions for ALL VEHICLES on Page #20.



## FORD Aerostar 1985-91

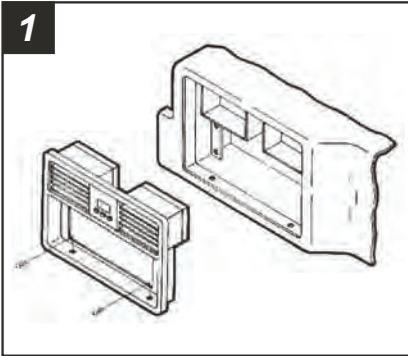

1  
Disconnect the negative battery terminal to prevent an accidental short circuit. Remove (2) Phillips screws from the base of the dash panel. Pry down on the (2) tabs located at the top of the radio trim bezel and remove the bezel. Remove (4) screws securing the factory head unit and disconnect the wiring.

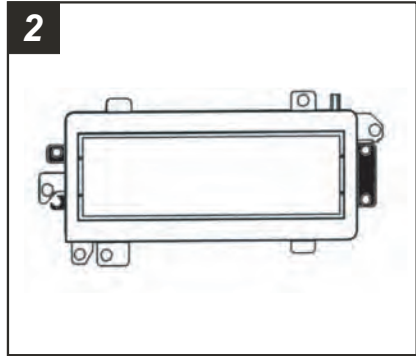

2  
Cut and remove all mounting tabs on the Radio Housing EXCEPT the shaded tabs. Skip to the Installation Instructions for ALL VEHICLES on Page #20.

## FORD Bronco II / Ranger (mini) 1985-88

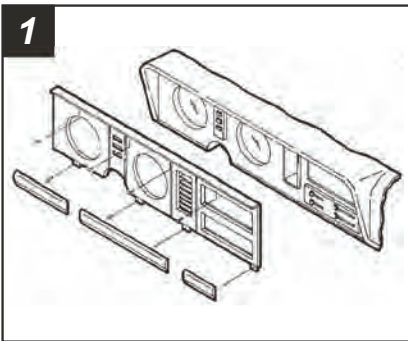

1  
Disconnect the negative battery terminal to prevent an accidental short circuit. Remove (4) Phillips screws from the top edge of the dash trim bezel. Remove the light switch knob, cigarette lighter and ashtray. Unsnap the molding under the dash trim bezel and remove (4) screws exposed. Remove (4) screws securing the factory head unit and disconnect the wiring.

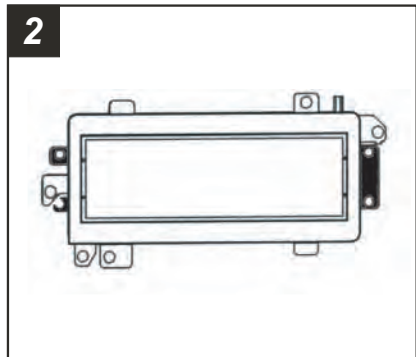

2  
Cut and remove all mounting tabs on the Radio Housing EXCEPT the shaded tabs. Skip to the Installation Instructions for ALL VEHICLES on Page #20.

## **FORD Crown Victoria / LTD 1979-90 MERCURY Grand Marquis / Marquis 1979-90**

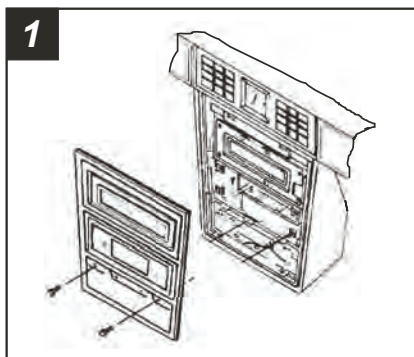

1  
Disconnect the negative battery terminal to prevent an accidental short circuit. Open the ashtray and remove (2) Phillips screws exposed. Remove the dash trim bezel. Remove (4) screws securing the factory head unit and disconnect the wiring.

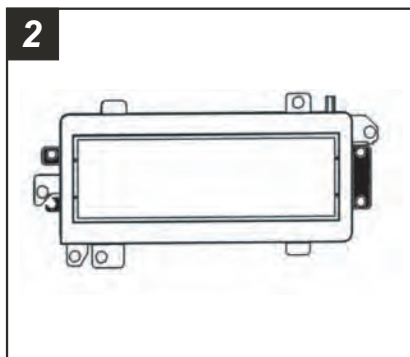

2  
Cut and remove all mounting tabs on the Radio Housing EXCEPT the shaded tabs. Skip to the Installation Instructions for ALL VEHICLES on Page#20.

## **FORD Thunderbird / MERCURY Cougar 1985-88**

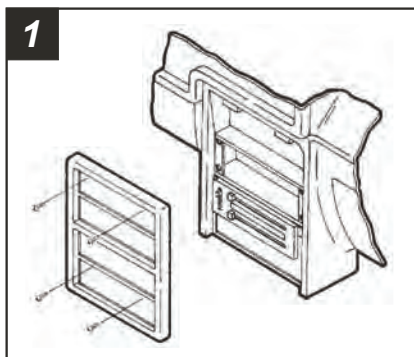

1  
Disconnect the negative battery terminal to prevent an accidental short circuit. Remove (2) screws from the top of the dash trim bezel. Open the ashtray and remove (2) screws exposed in the ashtray cavity. Remove the dash trim bezel. Remove (4) screws securing the factory head unit and disconnect the wiring.

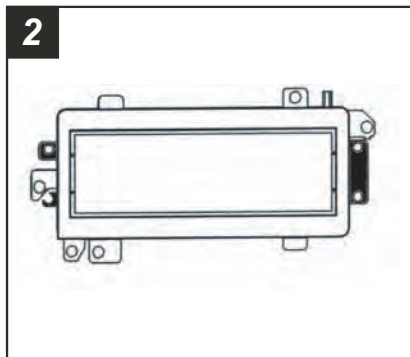

2  
Cut and remove all mounting tabs on the Radio Housing EXCEPT the shaded tabs. Skip to the Installation Instructions for ALL VEHICLES on Page#20.

## JEEP Cherokee 1997-01

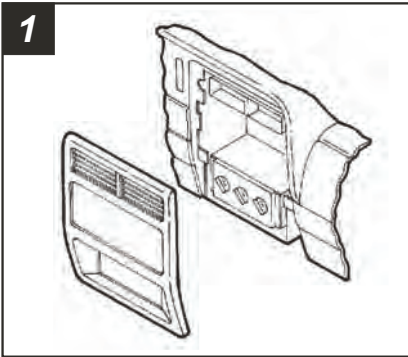

1  
Disconnect the negative battery terminal to prevent an accidental short circuit. Unclip the dash trim bezel. Remove (2) #10 hex-head screws securing the factory head unit and disconnect the wiring.

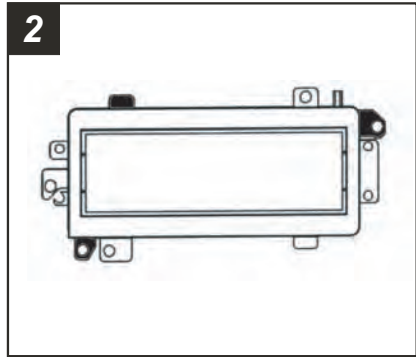

2  
Cut and remove all mounting tabs on the Radio Housing EXCEPT the shaded tabs. Skip to the Installation Instructions for ALL VEHICLES on Page #20.

## JEEP Grand Cherokee 1993-95

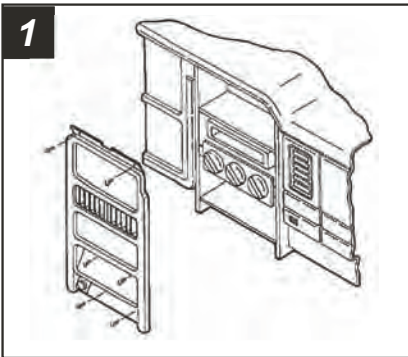

1  
Disconnect the negative battery terminal to prevent an accidental short circuit. Remove (2) Phillips screws from the bottom of the dash trim bezel. Remove (2) Phillips screws above the radio opening. Remove (2) Phillips screws to the left of the steering column. Remove (1) Phillips screw to the right of the steering column. Unclip the dash trim bezel and disconnect the wiring.

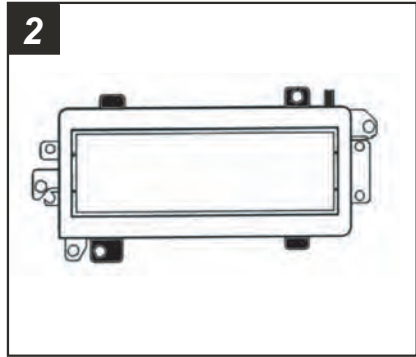

2  
Cut and remove all mounting tabs on the Radio Housing EXCEPT the shaded tabs. Skip to the Installation Instructions for ALL VEHICLES on Page #20.

## JEEP Grand Cherokee 1996-98

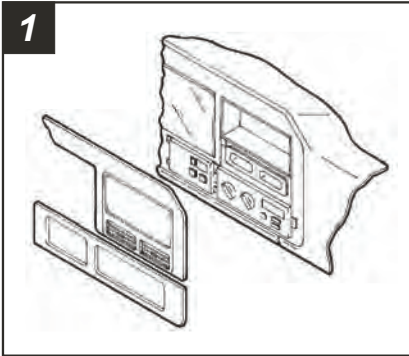

Disconnect the negative battery terminal to prevent an accidental short circuit. Unsnap the climate control/wiper control trim panel and remove. Remove (5) Phillips screws from the top of the radio/instrument cluster trim bezel. Remove (4) Phillips screws from the bottom of the radio/instrument cluster trim bezel. Pry out on the bottom edge of the bezel and remove. Remove (2) 3/8" hex-head screws securing the factory head unit and disconnect the wiring.

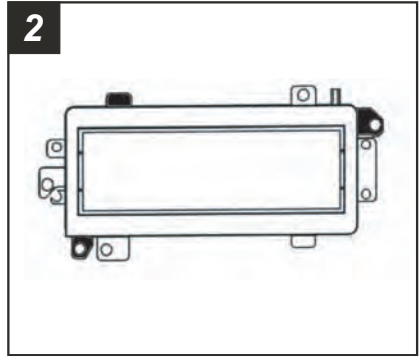

Cut and remove all mounting tabs on the Radio Housing EXCEPT the shaded tabs. Skip to the Installation Instructions for ALL VEHICLES on Page #20.

## JEEP Wrangler 1997-02

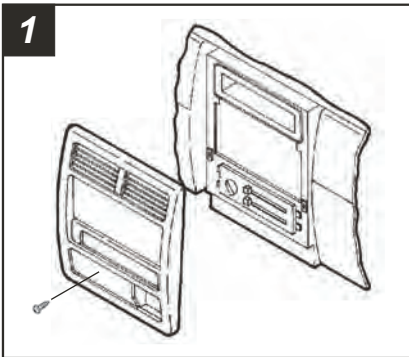

Disconnect the negative battery terminal to prevent an accidental short circuit. Remove the ashtray and (1) Phillips screw exposed in the ashtray cavity. Pry out on the top cover of the instrument panel and remove (2) Phillips screws exposed. Pry out on the bottom edge of the dash trim bezel and remove. Remove (2) 3/8" hex-head screws securing the factory head unit and disconnect the wiring.

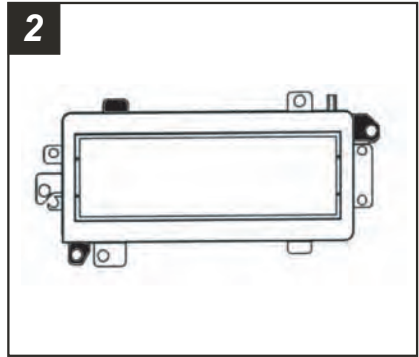

Cut and remove all mounting tabs on the Radio Housing EXCEPT the shaded tabs. Skip to the Installation Instructions for ALL VEHICLES on Page #20.

## LINCOLN Continental 1985-87

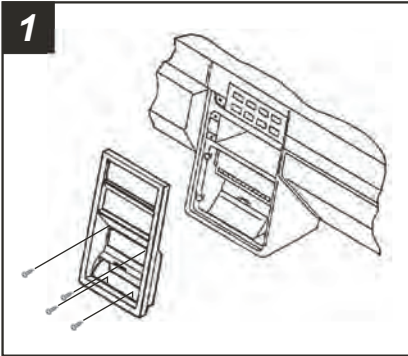

1  
Disconnect the negative battery terminal to prevent an accidental short circuit. Remove (2) #8 Phillips screws below the radio opening. Open the ashtray and remove (2) #8 Phillips screws (it is NOT necessary to remove the center screw). Unclip the dash trim bezel and remove. Remove (4) hex-head screws securing the factory head unit and disconnect the wiring.

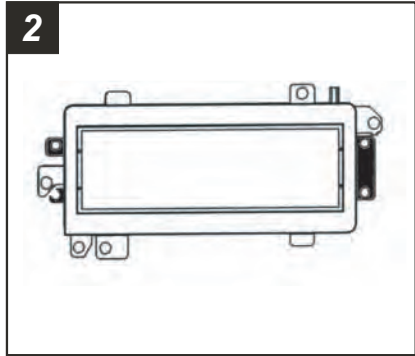

2  
Cut and remove all mounting tabs on the Radio Housing EXCEPT the shaded tabs. Skip to the Installation Instructions for ALL VEHICLES on Page #20.

## LINCOLN Mark VII 1984-89

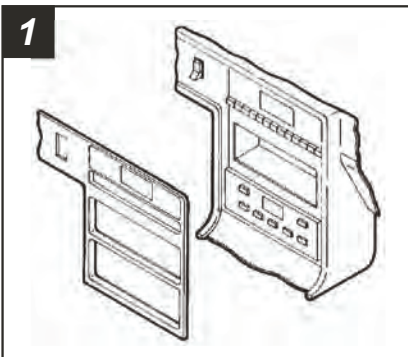

1  
Disconnect the negative battery terminal to prevent an accidental short circuit. Pry out on the dash trim bezel and remove. Remove (4) 5mm hex-head sheet metal screws securing the factory head unit and disconnect the wiring.

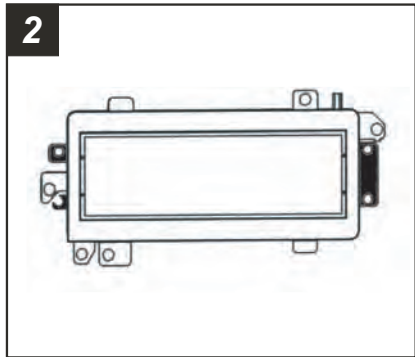

2  
Cut and remove all mounting tabs on the Radio Housing EXCEPT the shaded tabs. Skip to the Installation Instructions for ALL VEHICLES on Page #20.

## ALL VEHICLES

3

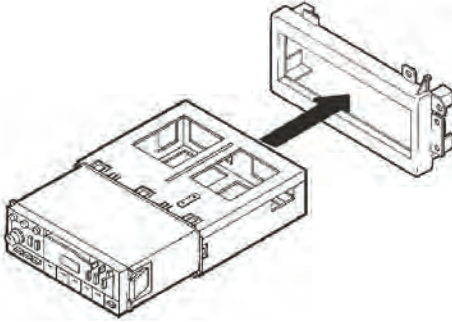

**DIN HEAD UNITS:** Slide the DIN cage into the Radio Housing and secure by bending the metal locking outward. Slide the aftermarket head unit into the cage until secure.

4

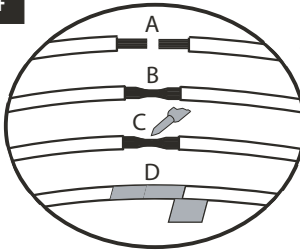

- A) Strip wire ends back 1/2"
- B) Twist ends together
- C) Solder
- D) Tape

Locate the factory wiring harness in the dash. Metra recommends using the proper mating adaptor and making connections as shown. (Isolate and individually tape off the ends of any unused wires to prevent electrical short circuit).

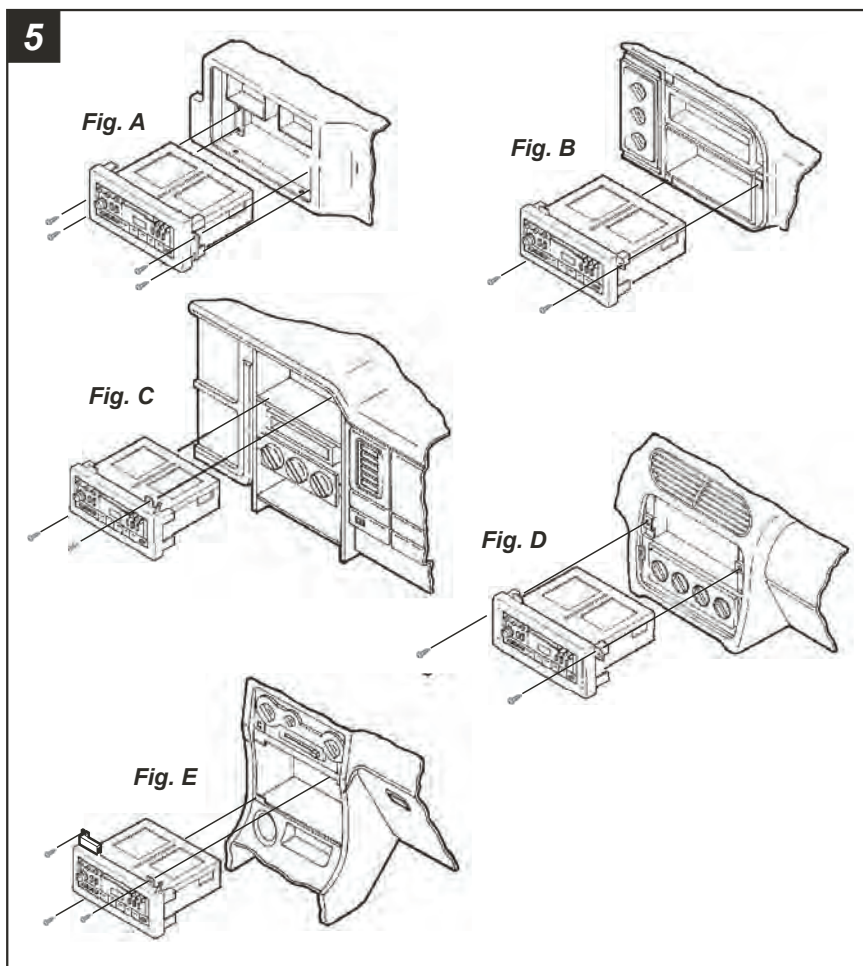

**FORD / LINCOLN / MERCURY:** Mount the head unit/kit assembly to the sub-dash with (4) screws previously removed in step #1.(see Fig. A)

**CHRYSLER / DODGE / PLYMOUTH / EAGLE / JEEP (Excluding GRAND CHEROKEE 1993-95, CIRRUS, STRATUS, BREEZE, SEBRING, AVENGER):** Mount the head unit/kit assembly to the sub-dash with (2) 3/8" hex-head screws previously removed in step #1. (see Fig. B)

**GRAND CHEROKEE 1993-95:** Mount the head unit/kit assembly to the sub-dash with (2) screws previously removed in step #1.(see Fig. C)

**CIRRUS, STRATUS, BREEZE:** Mount the head unit/kit assembly to the sub-dash with (2) screws previously removed in step #1.(see Fig. D)

**SEBRING, A VENGER:** Remove the top-left screw from the metal dash housing. Mount the head unit/kit assembly to the sub-dash with (2) screws previously removed in step #1. Replace the metal housing screw through the top Support Spacer. (see Fig. E)

