

KIT FEATURES

- ▶ DIN head unit provisions
- ▶ CD jewel case pocket (holds 2 jewel cases)



99-7007 INSTALLATION INSTRUCTIONS

KIT COMPONENTS

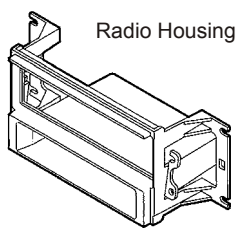

APPLICATIONS

CAR

PAGE

MITSUBISHI

Eclipse 2000-05.....	1
Montero Sport 2000-04.....	1

TOOLS REQUIRED



Phillips screwdriver



Cutting tool



1-800-221-0932



www.metraonline.com

© COPYRIGHT 2001-07 METRA ELECTRONICS CORPORATION

rev. 06-14-07

MITSUBISHI Eclipse 2000-05

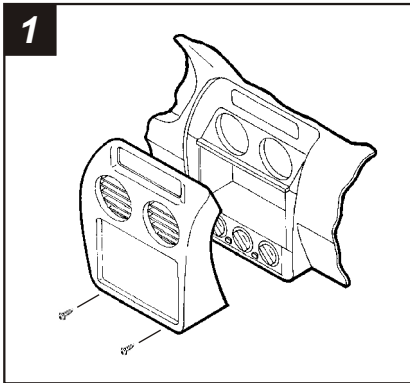

1
Disconnect the negative battery terminal to prevent an accidental short circuit. Remove (2) Phillips screws under the climate controls. Unclip the radio/climate control trim bezel and remove the bezel. Remove (4) Phillips securing the factory head unit and disconnect the wiring.

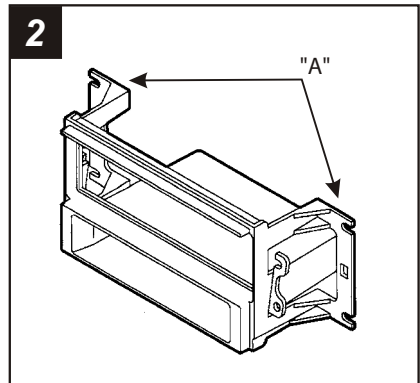

2
Locate tabs "A" on the Radio Housing. Skip to the Installation Instructions for ALL VEHICLES on Page #2.

MITSUBISHI Montero Sport 2000-04

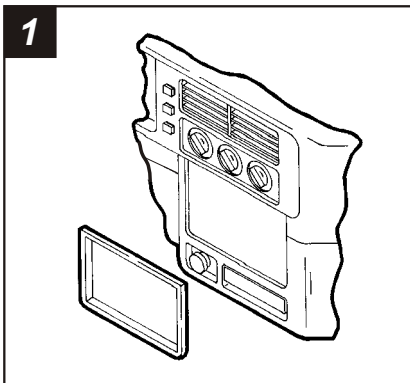

1
Disconnect the negative battery terminal to prevent an accidental short circuit. Unclip the radio/climate control trim bezel and remove the bezel. Remove (4) Phillips securing the factory head unit and disconnect the wiring.

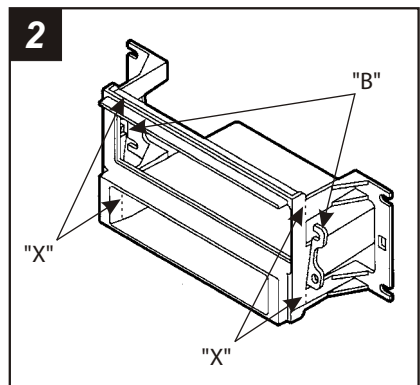

2
Locate tabs "B" on the Radio Housing. Cut and remove the mounting legs containing tabs "A" by cutting along dotted lines "X". Skip to the Installation Instructions for ALL VEHICLES on Page #2.

ALL VEHICLES

3

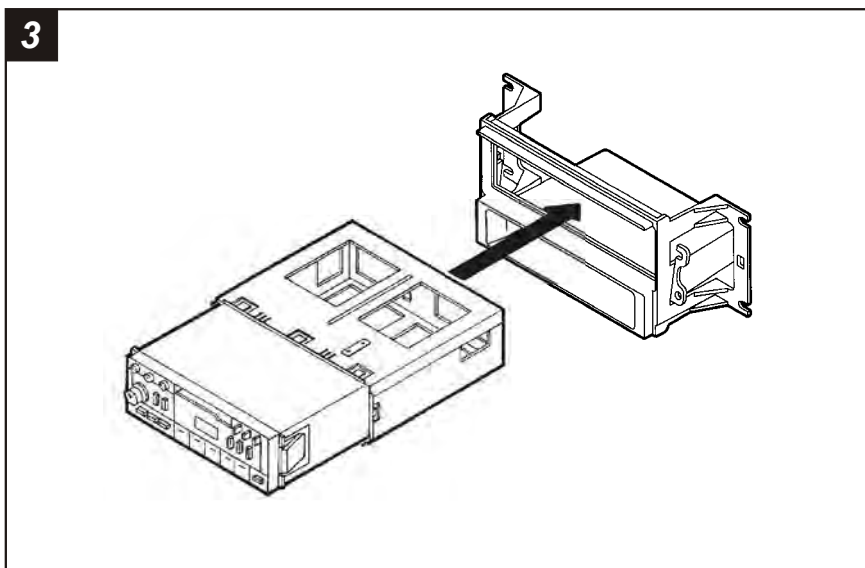

Slide the DIN cage into the Radio Housing and secure by bending the metal locking tabs down. Slide the aftermarket head unit into the cage until secure.

4

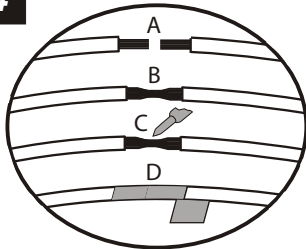

- A) Strip wire ends back ½"
- B) Twist ends together
- C) Solder
- D) Tape

Locate the factory wiring harness in the dash. Metra recommends using the proper mating adaptor and making connections as shown. (Isolate and individually tape off the ends of any unused wires to prevent electrical short circuit).

5

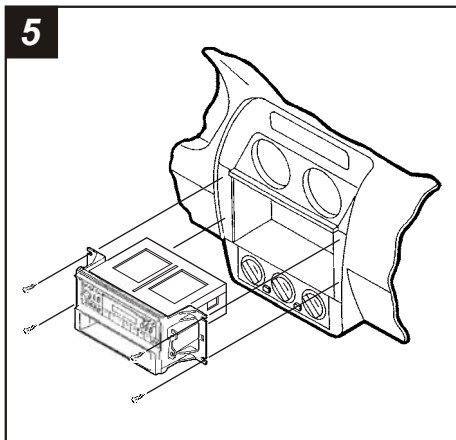

Re-connect the battery terminal and test the unit for proper operation. Mount the head unit/kit assembly to the sub-dash with (4) Phillips screws previously removed in step #1.